



AGENDA

Rogers Parks and Recreation Advisory Commission

December 11, 2025 - 5:30 PM

1. CALL TO ORDER AND PLEDGE OF ALLEGIANCE

2. OPEN FORUM

Individuals may address the Council about any item not contained on the regular agenda. A maximum of 10 minutes is allocated for the Forum. If the full 10 minutes are not needed for the Forum, the Mayor will continue with the agenda. If additional time is needed for the Forum, the Council will continue the Forum following Other Business on the agenda. The Council will take no official action on items discussed at the Forum, with the exception of referral to staff or Commission for future report.

3. PRESENTATIONS

3.1 Meet and Greet with the Student Liaison Candidate.

4. APPROVE AGENDA

Council members may add items to the agenda for discussion purposes or staff direction only. The Council will not normally take official action on items added to the agenda.

5. CONSENT AGENDA

These items are considered to be routine and will be enacted by one motion. There will be no separate discussion of these items unless a Councilmember so requests, in which event the item will be removed from the Consent Agenda and placed elsewhere on the agenda.

5.1 Approval of September PRAC Minutes and October Fieldhouse Tour notes.

6. GENERAL BUSINESS

6.1 Indoor Playground Adult/Supervisor Admission Fee Review

6.2 Consider Revised Option for Dutch Knolls Equipment Replacement

6.3 Consider North Community Park Playground Options

6.4 Selection of Preliminary Design Sunnyside Park Playground Replacement

6.5 Consider the updated plan for Crow River Heights Park

6.6 Consider the Student Liaison Application

6.7 Consider Summer Rental Request for South Community Park Rink(s)

6.8 Consider Park and Parking Lot Lighting Plans

6.9 2025 Work Plan

7. OTHER BUSINESS

8. CORRESPONDENCE AND REPORTS

8.1 Correspondence and Staff Report

9. ADJOURN



STAFF REPORT
**ROGERS PARKS AND
RECREATION ADVISORY
COMMISSION**

Meeting Date: December 11, 2025

Agenda Item: 3.1

Subject: Meet and Greet with the Student Liaison Candidate.

Prepared By:

Overview / Background / Analysis

Staff Recommendation

Financial Impact:

Source Fund:

Budgeted?

Supporting Documentation

None



STAFF REPORT

**ROGERS PARKS AND
RECREATION ADVISORY
COMMISSION**

Meeting Date: December 11, 2025

Agenda Item: 5.1

Subject: Approval of September PRAC Minutes and October Fieldhouse Tour notes.

Prepared By: Marcy Dalchow, Public Works Administrative Assistant

Overview / Background / Analysis

Staff Recommendation

Move to approve the September PRAC minutes and the October tour notes (no meeting in November).

Financial Impact:

Source Fund:

Budgeted?

Supporting Documentation

- A. October 8 2025 Tour of the Fieldhouse
- B. September 11 2025 Park Commission Minutes

Parks and Recreation Advisory Tour of the HealthPartners Fieldhouse October 9, 2025 5:30pm

With no Action items for October, the Parks and Recreation Advisory Commission (PRAC) meeting scheduled for Thursday, October 9 was a tour of the HealthPartners Fieldhouse at 14160 James Road, Rogers, MN 55374.

Prior to the meeting, the following updates were shared with the PRAC in an e-mail informing them the regular meeting was canceled.

- Student Liaison Update: We have not received any student liaison applications at this time.
- Save the Date:
The TruStone Center Dedication and HealthPartners Fieldhouse Grand Opening are scheduled for Monday, November 17, 5:00–8:00 p.m.
- Reminder: Our next regular PRAC meeting is Wednesday, November 12.

Dale Fuller, Peggy Warfield, Paul Hacker, Judi Volkens, Mike Volkens, Sam Okland, Chris Morrow, Amy Enga, Mike Bauer and Marcy Dalchow attended the fieldhouse for the tour.

Commissioners were very impressed with the fieldhouse and were extremely happy to see their vision and dreams of something this nice for the residents of Rogers come true.

Many questions were asked relating to the turf, walking path, heating and cooling of the facility, etc. Most questions were answered and answers to others would be learned on Friday at the turf owner training with Terra Construction.

The tour concluded with a group photo. (Sam Okland had already left)



**Park and Recreation Advisory Commission Meeting Minutes
September 11, 2025**

1. CALL TO ORDER AND PLEDGE OF ALLEGIANCE

The Park and Recreation Advisory Commission (PRAC) meeting of the City of Rogers was called to order by Commissioner J. Volkers on Thursday, September 11, 2025, at 5:30pm at Sunny Side Park, 22184 138th Ave. N., Rogers MN, 55374.

Roll Call

Dale Fuller	Parks and Recreation Advisory Commissioner – Chair	Absent
Peggy Warfield	Parks and Recreation Advisory Commissioner - Vice Chair	Absent
Paul Hacker	Parks and Recreation Advisory Commissioner	
Judi Volkers	Parks and Recreation Advisory Commissioner	
Mike Volkers	Parks and Recreation Advisory Commissioner	
Sam Okland	Parks and Recreation Advisory Commissioner	
Chris Morrow	Parks and Recreation Advisory Commissioner	
Shannon Klick	Rogers City Council – Mayor	
Mike Bauer	Parks and Recreation Director	
Marcy Dalchow	Public Works Administrative Assistant	
Van Satlak	Sunny Side & Henry’s Woods Parks	
Sarah Botta	Sunny Side Neighborhood	
Sean Johnson	Sunny Side Neighborhood	
Jeff Livingston	Rogers Resident	

2. OPEN FORUM

Several residents and their children attended the September PRAC Meeting. Residents were told their playground equipment would be replaced next summer and that there would be a mailing inviting them to a public meeting, postings on social media sites and lots of opportunities for public input.

The children and parents who attended this meeting were asked what they would like to see in their park in the future and if there were any issues they would like addressed. The children had many ideas for the park improvements. They would like a club house, a taller two story something, a climbing wall, a longer zipline, more color (they must not like the green and beige), to expand the park to include a basketball court and spinning things - preferably a merry go round. The parents would like some shade, at least three frisbee golf structures and at maybe a quarter court with a basketball hoop.

One issue was brought up; there hasn't been a porta potty at Sunnyside since some older kids tipped it over a few years ago. They would like a porta potty there again.

3. PRESENTATIONS None

4. APPROVE AGENDA

4.1 Approval of Consent Agenda

Motion to approve the agenda as submitted by Okland, seconded by Morrow. Motion carried 5/0.

5. CONSENT AGENDA

5.1 Approval of the August 2025 Minutes

Motion to approve the August 2025 Minutes by M. Volkers, seconded by Morrow. Motion carried 5/0.

6. GENERAL BUSINESS

6.1 Consider Options for Dutch Knolls Equipment Replacement

Dutch Knolls Park previously included an X-Wave play feature. The manufacturer notified staff that the piece would need to be removed for safety reasons once cracks developed on the X-Wave. An inspection revealed cracks occurred recently and Park Maintenance Staff removed the X-Wave. The PRAC and City now have an opportunity to select a replacement piece for Dutch Knolls Park to serve children in the 5-12 age range. Three replacement options from Landscape Structures/Flagship Recreation were presented for consideration. Option #1, the double bobble rider/We-saw was selected by the PRAC. A stand-alone slide will also be priced as replacements for the X-Wave at Dutch Knolls Park.

6.2 Consider design, bid, and construction administration for park shelters

Previously staff was directed to design and install new park shelters at Erickson Park, Fox Creek West Park and Laurel Creek Park. To proceed with this project, staff solicited a proposal from Anderson Engineering of Minnesota, LLC. Anderson Engineering has prepared a detailed scope of services to support the city throughout the process. The total fixed fee for Anderson's services is \$7,750. Their timeline and deliverables meet the summer of 2026 plan to complete the project.

Motion to recommend the Rogers City Council approve the engagement of Anderson Engineering of MN, LLC for the park shelter project (design, bid and manage the construction) by Okland, seconded by Morrow. Motion carried 5/0.

6.3 2025 Work Plan Reviewed

Highlights:

- Council recommended staff apply for a Hennepin County Youth Sports Grant for the ice expansion project.
- More bad soils were uncovered at Territorial Park resulting in \$30,000 of necessary soil corrections.
- Most of the turf has been installed in the fieldhouse.
- Rachael Walters began as the Fieldhouse Operations Supervisor on August 28, 2025. She has been ordering nets, athletic equipment, garbage cans and other items needed for the fieldhouse. As well, she has been working with Travis from the RAC to interview part-time help for the fieldhouse and answering many questions about the new facility. There is a lot of public interest in the fieldhouse.
- Work on the trails at South Community Park (SCP) began this week.

7. OTHER BUSINESS None

8. CORRESPONDENCE AND REPORTS

8.1 Correspondence and Staff Update Reviewed

(one low light):

- Alex Heuvels has submitted his resignation as a Student Liaison for the Park and Recreation Advisory Commission.

9. ADJOURN

Motion to Adjourn at 6:34pm by Okland, seconded by Morrow. Motion carried 5/0.



STAFF REPORT

ROGERS PARKS AND RECREATION ADVISORY COMMISSION

Meeting Date: December 11, 2025

Agenda Item: 6.1

Subject: Indoor Playground Adult/Supervisor Admission Fee Review

Prepared By: Mike Bauer, Parks & Recreation Director

Overview / Background / Analysis

At the recommendation of Commissioner Judi Volkens, staff is bringing forward a discussion item regarding admission pricing for the indoor playground, specifically whether adults or supervisors should be charged an entry fee.

When the indoor playground opened, the initial pricing model assumed that every person entering the space would impact playground capacity, regardless of age. For that reason, the admission rate was applied uniformly to children and accompanying adults. Another operator recommended this: change less but charge for all. The purpose was to support capacity management, staffing levels, facility wear, and revenue stability.

To date, attendance has remained well below capacity, even during our highest use sessions. Because we have not experienced crowding concerns, the original capacity-based rationale for charging adult admission may no longer be necessary at this time.

In addition, staff has received feedback from residents questioning the policy of charging parents or guardians to supervise their children. This community input, coupled with the recommendation from Commissioner Volkens, prompted staff to review peer practices and reevaluate whether the current approach aligns with community expectations and operational needs.

Resident Correspondence

Staff have received multiple messages from residents regarding adult admission charges for the indoor playground. Complete copies of these emails are attached to this agenda packet. The primary themes expressed in the correspondence include:

- Concern that adults who are supervising and not actively participating are required to pay admission fees
- Questions about how this compares to neighboring indoor playgrounds, where only children are charged
- Requests that the City reconsider the current policy and allow free entry for supervising adults

Regional Market Comparison

Staff reviewed comparable indoor playgrounds operated by both municipalities and private companies throughout the metro region. In nearly all cases, admission fees apply only to participating children, while accompanying adults are admitted free.

Comparable facilities include the following:

Backyard Indoor – Golden Valley

<https://www.brookviewbackyard.com/>

\$6 child admission, adults free

K.U.B.E. Indoor Playground – Plymouth

<https://www.plymouthcommunitycenter.com/about/plymouth-community-center/indoor-playground>

\$6 resident and \$8 non resident admission, adults free

Maple Maze – Maple Grove

<https://maplegrovern.gov/288/Maple-Maze>

\$6.25 child admission, adults free. Facility management suggests charging all who enter the space

Treehouse – Minnetonka

<https://www.minnetonkamn.gov/our-city/williston-fitness-center/treehouse>

\$7 child admission, adults free

The Blast – Eagan

<https://cityofeagan.com/blast>

\$8 child admission, adults free

Lookout Ridge – Woodbury

<https://www.woodburymn.gov/164/Lookout-Ridge-and-Birthday-Parties>

\$8 child admission, adults free

Eagles Nest – New Brighton

<https://www.newbrightonmn.gov/308/Eagles-Nest-Indoor-Playground>

\$9 child admission, adults free

Edinborough Park – Edina

<https://www.edinamn.gov/1604/PlayPark>

\$10 child admission daily with family membership options, adults free

Goodtimes Park – Woodbury and Eagan

<https://goodtimesparkwdbry.rhombnow.com/>

\$12 child admission, adults free

Peekabooboos – Albertville

<https://peekabooboos.com/>

\$13.50 child admission, one adult free, \$6 for each additional adult

Avery's Adventures – Elk River

<https://averysadventures.com/>

\$13.99 first child and \$12.99 for additional children, two adults free

Key Observations

Across both municipal and private providers, the standard market practice is to charge admission for children while admitting accompanying adults at no cost. Municipal facilities in particular consistently allow free adult entry.

Discussion Items for the Commission

The Parks Commission is asked to consider the following questions:

1. Should adult or supervisor admission charges be eliminated for the indoor playground?
2. If adult fees are removed, should the individual child admission rate remain as is or be increased to offset any potential revenue loss?
3. Should a limit be placed on the number of free adults admitted with each child, such as up to two supervisors per child?

Recommendation Path

This item is presented for discussion and direction.

If the Parks Commission reaches consensus on a policy change regarding adult admission or individual child pricing, staff will bring forward a proposed adjustment to the City Council for formal consideration and action on the City's fee schedule.

Staff Recommendation

Financial Impact:

Source Fund:

Budgeted?

Supporting Documentation

- A. Turf Admissions
- B. Playground Correspondence

**SECTION 1
TRUSTONE CENTER (CONTINUED)**

Description	Account	2025	2026
THRIVE ROOM (HEALTHPARTNERS FIELDHOUSE)			
Refundable Damage Deposit	205-000-0000-22000-0000	N/A	200.00
Resident Per Hour (60 Minutes)	205-450-5205-36222-0000	N/A	40.00
Non-Resident Per Hour (60 Minutes)	205-450-5205-36222-0000	N/A	60.00
Not-for-Profit Organization (Self Setup and Take Down) Per Hour/3 Hour Minimum (Max 1 Event/Month)	205-450-5205-36222-0000	N/A	10.00
Facility Impact Fee (Amplified Music) Per Event	205-450-5205-36222-0000	N/A	200.00
Facility Impact Fee (Food & Beverage 50 - 100 People) Per Event	205-450-5205-36222-0000	N/A	25.00
TURF ADMISSIONS			
Open Turf Time Resident (Drop In)	209-450-5207-34792-0000	5.00	5.00
Open Turf Time Resident Family Resident (Drop In)	209-450-5207-34792-0000	N/A	25.00
Open Turf Time Non-Resident (Drop In)	209-450-5207-34792-0000	7.00	7.00
Playground / Tot Time Resident*	209-450-5207-34792-0000	5.00	5.00
Playground / Tot Time Non-Resident*	209-450-5207-34792-0000	7.00	7.00
Individual Season Pass Resident (Open Turf and Playground)	209-450-5207-34796-0000	125.00	125.00
Individual Season Pass Non-Resident (Open Turf and Playground)	209-450-5207-34796-0000	175.00	175.00
Family Season Pass Resident (Open Turf and Playground)	209-450-5207-34796-0000	400.00	400.00
Family Season Pass Non-Resident (Open Turf and Playground)	209-450-5207-34796-0000	560.00	560.00
Walking Track Resident (Based on Availability)	209-450-5207-34792-0000	No Charge	No Charge
Walking Track Non-Resident (Based on Availability)	209-450-5207-34792-0000	5.00	5.00
Walking Track Non-Resident Annual Pass (Based on Availability)	209-450-5207-34796-0000	125.00	125.00
*Rates are for ages 2 and older. Children must be accompanied by a paid adult.			
TURF RENTAL RATES Per Hour			
Winter Season Prime (October 15 - May 15) Full Field	209-450-5207-34785-0000	375.00	385.00
Winter Season Prime (October 15 - May 15) Half Field	209-450-5207-34785-0000	200.00	205.00
Winter Season / Non-Prime Full Field	209-450-5207-34785-0000	300.00	310.00
Winter Season / Non-Prime Half Field	209-450-5207-34785-0000	160.00	165.00
Winter Season Last Chance / Day Time Programming Full Field	209-450-5207-34785-0000	250.00	255.00
Winter Season Last Chance / Day Time Programming Half Field	209-450-5207-34785-0000	140.00	145.00
Summer Prime Rate Full Field	209-450-5207-34785-0000	150.00	155.00
Summer Prime Rate Half Field	209-450-5207-34785-0000	80.00	80.00
Summer Full Day	209-450-5207-34785-0000	800.00	800.00
Summer Non Prime Full Field	209-450-5207-34785-0000	120.00	120.00
Summer Non Prime Half Field	209-450-5207-34785-0000	70.00	70.00
Batting Cages Per Tunnel (Includes Machine)	209-450-5207-34783-0000	55.00	55.00

Sent via form submission from City of Rogers, MN

Name: Christian Worby

Subject: Insane policy

Message: Dear Sir/Madam,

I was just looking at the pricing for the new Fieldhouse.

So, if I want my child to be able to play in the play area, I have to pay not only \$7 for him to play, but also \$7 for me to stand there and watch him play?

\$14 to play in a little playground for one hour while his brother is practising soccer?

\$14?

Wow.

All the best,

Christian

From: Rachael Kolles

Sent: Monday, December 8, 2025 9:41 AM

Subject: RE: Form Submission - Contact City of Rogers - Insane policy

Hi Christian,

Thank you for reaching out.

In researching playground pricing across the market, we've found that our rates are approximately half the cost of comparable indoor facilities. After speaking with other operators, they recommended keeping pricing lower and applying it to all users equally, since everyone present counts toward the playground's overall capacity. This includes supervising adults, as they still occupy space and factor into safe capacity management.

A similar approach applies to the walking track. Our goal is to ensure a good experience for everyone using the space. There is a balance between accessibility and crowding. If everyone in the building were using the track at the same time, it would quickly become congested and would not be an enjoyable experience for anyone.

Best,

Rachael Kolles

Fieldhouse Operations Supervisor

From: Squarespace <form-submission@squarespace.info>

Sent: Saturday, November 29, 2025 6:10 PM

To: Department - Administration - Info <info@rogersmn.gov>

Subject: Form Submission - Contact City of Rogers - Rogers In door Field Facility
Playground

Name: Erica Prairie

Subject: Rogers In door Field Facility Playground

Message: Hi! My two children play soccer for Boreal (of which we already pay significant extra fees to be in the new facility. It is nice. However, I have a concern regarding the walking track and especially the playground.

Since the club has a contract and provides significant business to this new space, it does seem reasonable that parents of players should get a significant discount for using the space (or most similar accommodations do not charge at all to use the walking track).

The playground is especially ridiculous because it requires supervision and that the adult also pay. Again most indoor playgrounds do not also charge the adult supervisor. I was completely caught off guard that it requires an adult to supervise and they have to pay.

I think your policies should be re-evaluated to be more reasonable for those families who are regular users of the facility like boreal families.

Thanks,

EP

Hello Erica,

Thank you for taking the time to email us and share your feedback. We truly appreciate you reaching out, and we appreciate your patience as well. This first year at the HealthPartners Fieldhouse has been a significant learning experience for our team as we introduce the facility, observe how residents and partners use the spaces, and continue to fine-tune

operations to serve the community best. We are only about one month into operations and still ramping up toward being fully operational, so ongoing evaluation and future adjustments are certainly part of the plan as we better understand usage patterns, capacity needs, and community expectations.

In researching playground pricing across the market, we've found that our rates are approximately half the cost of comparable indoor facilities. After speaking with other operators, they recommended keeping pricing lower and applying it to all users equally, since everyone present counts toward the playground's overall capacity. This includes supervising adults, as they still occupy space and factor into safe capacity management.

A similar approach applies to the walking track. Our goal is to ensure a good experience for everyone using the space. There is a balance between accessibility and crowding. If everyone in the building were using the track at the same time, it would quickly become congested and would not be an enjoyable experience for anyone.

We truly value our partnerships with our renters, including Boreal and the many families who actively use the facility. We encourage authorized representatives from our partner organizations to reach out to us if they would like to discuss potential additional terms or options within their rental agreements. We already provide significant group discounts for items such as meeting room rentals, and we remain open to continued discussions as we move through this inaugural year of operations.

Thank you again for your thoughtful feedback and for being part of our growing Fieldhouse community. Your input is helpful as we continue to learn and improve.

Please don't hesitate to reach out if you have any additional questions.

Best regards,

Parks and Recreation Director

Mike Bauer



STAFF REPORT

ROGERS PARKS AND RECREATION ADVISORY COMMISSION

Meeting Date: December 11, 2025

Agenda Item: 6.2

Subject: Consider Revised Option for Dutch Knolls Equipment Replacement

Prepared By: Mike Bauer, Parks & Recreation Director

Overview / Background / Analysis

Dutch Knolls Park previously included an X-Wave play feature. The manufacturer notified staff that the piece would need to be removed once cracks developed due to safety concerns. Cracks occurred recently, and Park Maintenance staff have since removed the equipment.

Following this removal, three replacement concepts were presented to the Parks and Recreation Advisory Commission in September 2025. The Commission discussed play value, accessibility, and cost among the options and provided feedback to staff to develop a revised plan with a standard slide option that balances active play opportunities with cost efficiency and compatibility within the existing play container.

Revised Design

Based on Commission input, staff worked with **Flagship Recreation** to refine the design to include a combination of motion and cooperative-play elements consistent with the preferred features from prior options.

The final layout includes:

- **72" Wave Poly Slide** – provides a traditional sliding element suitable for the 5–12 age range.
- **Double Bobble Rider** – offers side-to-side and front-to-back motion for two users.
- **We-Saw** – an inclusive multi-user motion feature that accommodates up to four children, including space for a wheelchair participant.

This configuration fits entirely within the existing play container (725 sq. ft.) and meets ASTM and ADA standards for safety surfacing and accessibility.

Budget Summary

Item	Cost	Notes
Equipment (State Contract Pricing)	\$26,449.00	Includes slide, Double Bobble Rider, and We-Saw
State Contract Discount (6%)	-\$1,586.94	Per State Contract #218091
Delivery and Mobilization	\$1,350.00	Includes equipment transport and setup
Site Preparation & Installation	\$6,712.96	Includes removal of existing surfacing and installation
Preliminary Total	\$33,511.96	Estimated total project cost Preliminary Design & Budget_Dut...

Staff Recommendation

Provide direction to staff on the preferred replacement option for Dutch Knolls Park.

Financial Impact:

Source Fund: 404-Capital Reserves

Budgeted?

Supporting Documentation

- A. Preliminary Design & Budget_Dutch Knoll_OPT1_8-25-25
- B. Preliminary Design & Budget_Dutch Knoll_OPT2_8-25-25
- C. Preliminary Design & Budget_Dutch Knoll_OPT3_8-25-25
- D. Preliminary Design & Budget_Dutch Knoll_12-10-25

CONTAINER DETAILS

TOTAL EXCAVATED AREA	558 SF
ASTM SAFETY SURFACING TYPE	ENGINEERED WOOD FIBER
TOTAL NEW EWF AREA	558 SF
EDGING TYPE	EXISTING CONCRETE CURB
FINISH GRADE	TOP OF CURB

****SITE PREPARATION REQUIREMENTS:**

- MAXIMUM OF 1% GRADE CHANGE ACROSS CONTAINER
- NO PRE-INSTALLED DRAIN TILE OUTSIDE OF 4 FEET OF PERIMETER
- DRAIN TILE STUB TO BE PROVIDED IF DRAIN TILE IS REQUIRED
- NO DRAINAGE AGGREGATE PRE-INSTALLED
- NO FABRIC PRE-INSTALLED
- MINIMUM CONTAINER SIZE NEEDED DENOTES THE INSIDE OF CURB DIMENSION

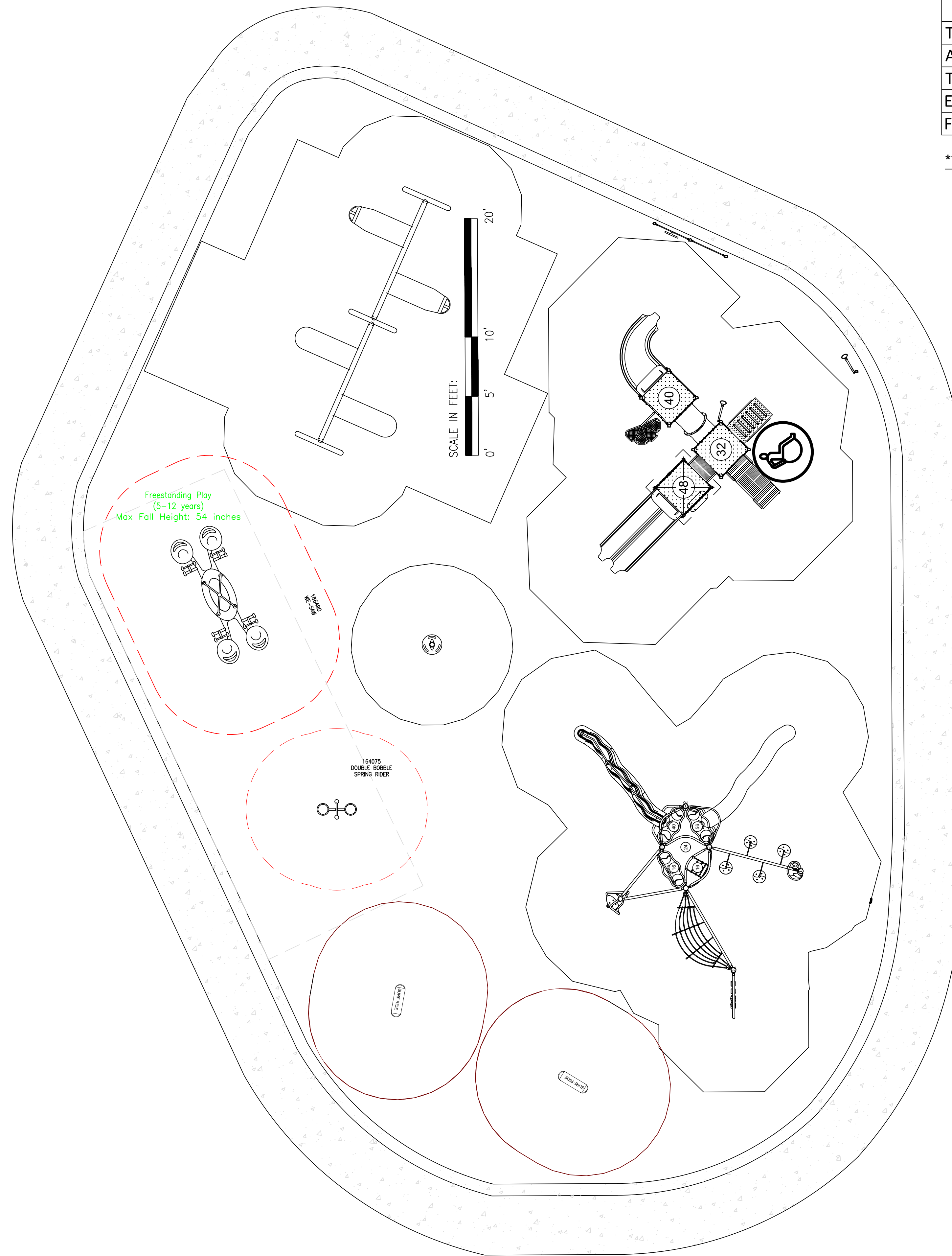

5-12 AREA (New equipment only)

TOTAL ELEVATED PLAY COMPONENTS	TBD		
TOTAL ELEVATED COMPONENTS ACCESSIBLE BY RAMP	0	REQUIRED	0
TOTAL ELEVATED COMPONENTS ACCESSIBLE BY TRANSFER	0	REQUIRED	0
TOTAL ACCESSIBLE GROUND LEVEL COMPONENTS SHOWN	2	REQUIRED	0
TOTAL DIFFERENT TYPES OF GROUND LEVEL COMPONENTS	1	REQUIRED	1



FLAGSHIP RECREATION
 11123 UPPER 33RD ST N
 LAKE ELMO, MN 55082
 763-550-7860
 FLAGSHIPPLAY.COM
 @FLAGSHIPPLAY



THIS PLAY AREA & PLAY EQUIPMENT IS
 DESIGNED FOR AGE RANGES AS NOTED
 ON PLAN.

**Dutch Knolls Park
 Option 1**

21900 Elm Pkwy, Rogers, MN 55374

SALES REPRESENTATIVE:
 Brett Altergott

DESIGNED BY:
 JLZT
 8/25/25

3/16" = 1'-0"

SHEET

LS101

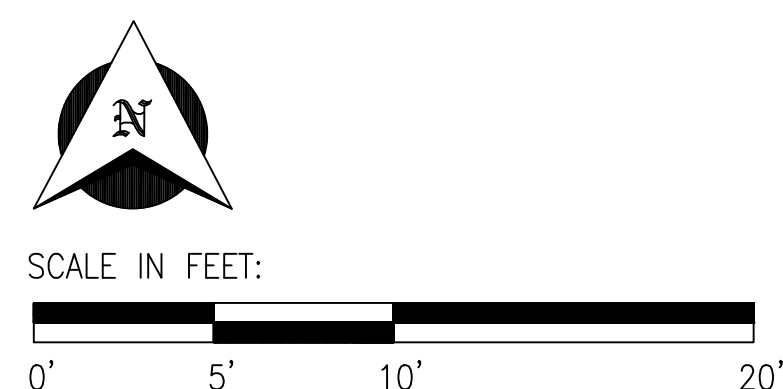



State Contract #218091



PROJECT INFORMATION

Dutch Knolls Park Opt 1

21900 Elm Pkwy

Rogers, MN 55374

Contract Year: 2025

EQUIPMENT INFORMATION & PRICING

Qty	Item No.	Description	Price	Ext Price
1	164075B	Double Bobble Rider DB	\$2,820	\$2,820.00
1	186490A	We-saw DB Only	\$14,469	\$14,469.00

Total Equipment Cost at State Contract Pricing

\$17,289.00

CONTAINER DETAILS

TOTAL EXCAVATED AREA	555 SF
ASTM SAFETY SURFACING TYPE	ENGINEERED WOOD FIBER
TOTAL NEW EWF AREA	555 SF
EDGING TYPE	EXISTING CONCRETE CURB
FINISH GRADE	TOP OF CURB

****SITE PREPARATION REQUIREMENTS:**

- MAXIMUM OF 1% GRADE CHANGE ACROSS CONTAINER
- NO PRE-INSTALLED DRAIN TILE OUTSIDE OF 4 FEET OF PERIMETER
- DRAIN TILE STUB TO BE PROVIDED IF DRAIN TILE IS REQUIRED
- NO DRAINAGE AGGREGATE PRE-INSTALLED
- NO FABRIC PRE-INSTALLED
- MINIMUM CONTAINER SIZE NEEDED DENOTES THE INSIDE OF CURB DIMENSION

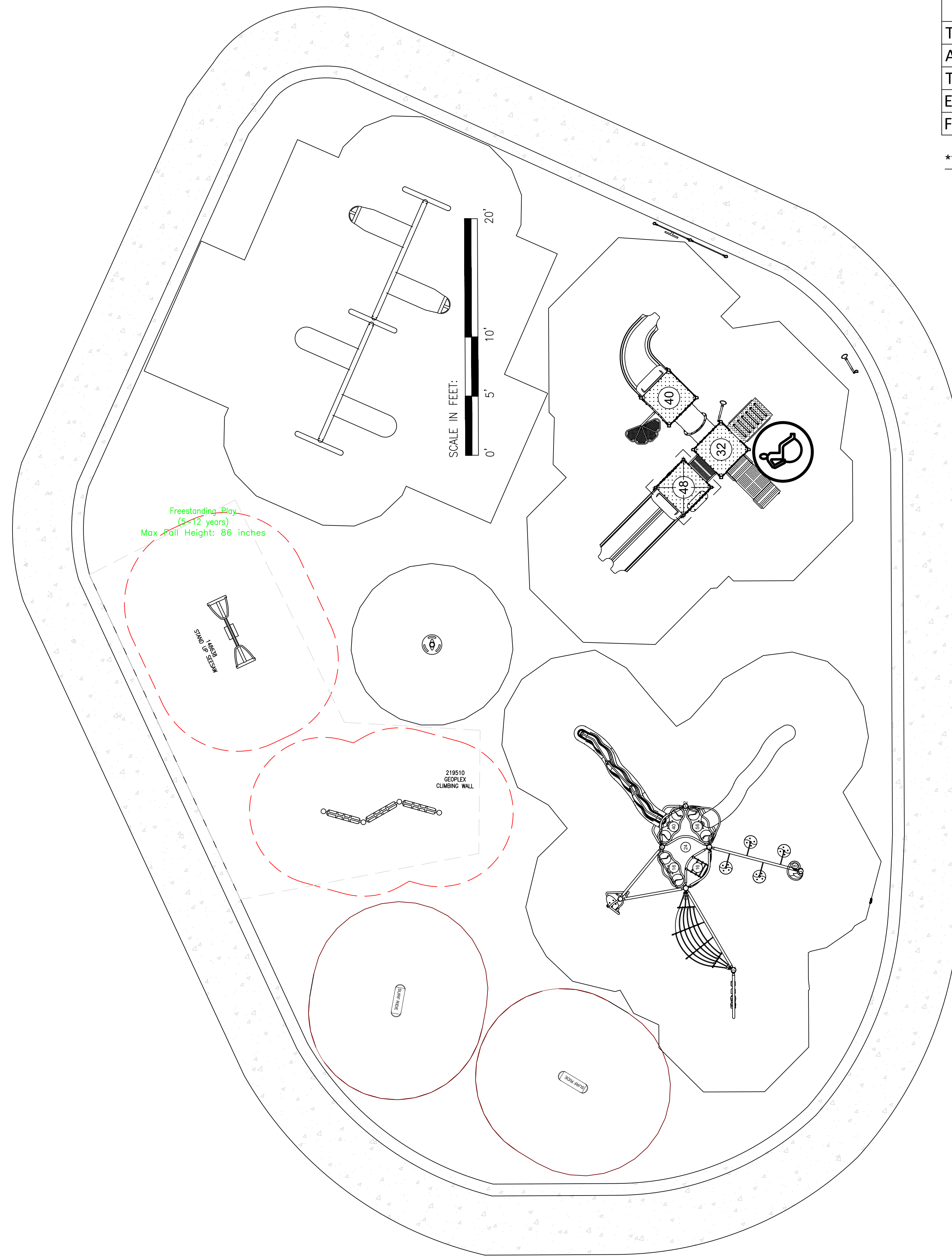

Freestanding Play
(5-12 years)
Max Pole Height: 86 inches

219510
SCOPES
CLIMBING WALL

Swing Set

Sand Pit

Sand Pit

5-12 AREA (New equipment only)

TOTAL ELEVATED PLAY COMPONENTS	TBD		
TOTAL ELEVATED COMPONENTS ACCESSIBLE BY RAMP	0	REQUIRED	0
TOTAL ELEVATED COMPONENTS ACCESSIBLE BY TRANSFER	0	REQUIRED	0
TOTAL ACCESSIBLE GROUND LEVEL COMPONENTS SHOWN	2	REQUIRED	0
TOTAL DIFFERENT TYPES OF GROUND LEVEL COMPONENTS	2	REQUIRED	2

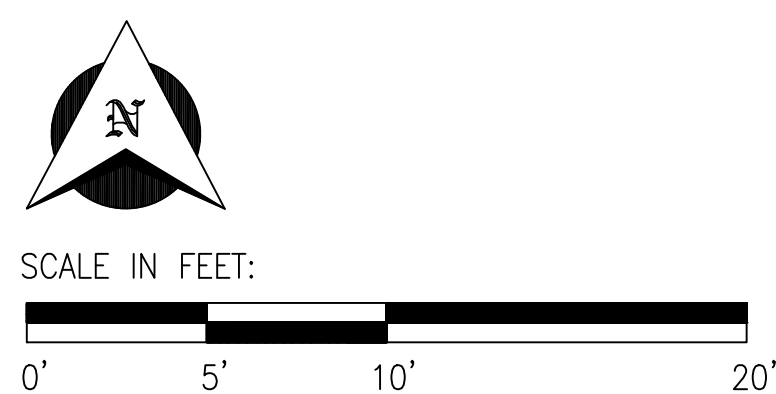

FLAGSHIP RECREATION
11123 UPPER 33RD ST N
LAKE ELMO, MN 55082
763-550-7860
FLAGSHIPPLAY.COM
@FLAGSHIPPLAY



THIS PLAY AREA & PLAY EQUIPMENT IS
DESIGNED FOR AGE RANGES AS NOTED
ON PLAN.

Dutch Knolls Park Option 2

21900 Elm Pkwy, Rogers, MN 55374

SALES REPRESENTATIVE:
Brett Altergott



DESIGNED BY:
JLZT
8/25/25

3/16" = 1'-0"

SHEET

LS101



 **Dutch Knoll Park - Opt 2**
Rogers_DutchKnoll 082525 Opt2 • 8.25.2025 

© 2025 Landscape Structures. All Rights Reserved

State Contract #218091



PROJECT INFORMATION

Dutch Knolls Park Opt 2

21900 Elm Pkwy

Rogers, MN 55374

Contract Year: 2025

EQUIPMENT INFORMATION & PRICING

Qty	Item No.	Description	Price	Ext Price
1	148638A	Stand-Up Seesaw DB	\$3,448	\$3,448.00
1	219510A	GeoPlex Climber Wall w/Alum Posts DB	\$7,186	\$7,186.00

Total Equipment Cost at State Contract Pricing

\$ 10,634.00

CONTAINER DETAILS

TOTAL EXCAVATED AREA	517 SF
ASTM SAFETY SURFACING TYPE	ENGINEERED WOOD FIBER
TOTAL NEW EWF AREA	517 SF
EDGING TYPE	EXISTING CONCRETE CURB
FINISH GRADE	TOP OF CURB

****SITE PREPARATION REQUIREMENTS:**

- MAXIMUM OF 1% GRADE CHANGE ACROSS CONTAINER
- NO PRE-INSTALLED DRAIN TILE OUTSIDE OF 4 FEET OF PERIMETER
- DRAIN TILE STUB TO BE PROVIDED IF DRAIN TILE IS REQUIRED
- NO DRAINAGE AGGREGATE PRE-INSTALLED
- NO FABRIC PRE-INSTALLED
- MINIMUM CONTAINER SIZE NEEDED DENOTES THE INSIDE OF CURB DIMENSION

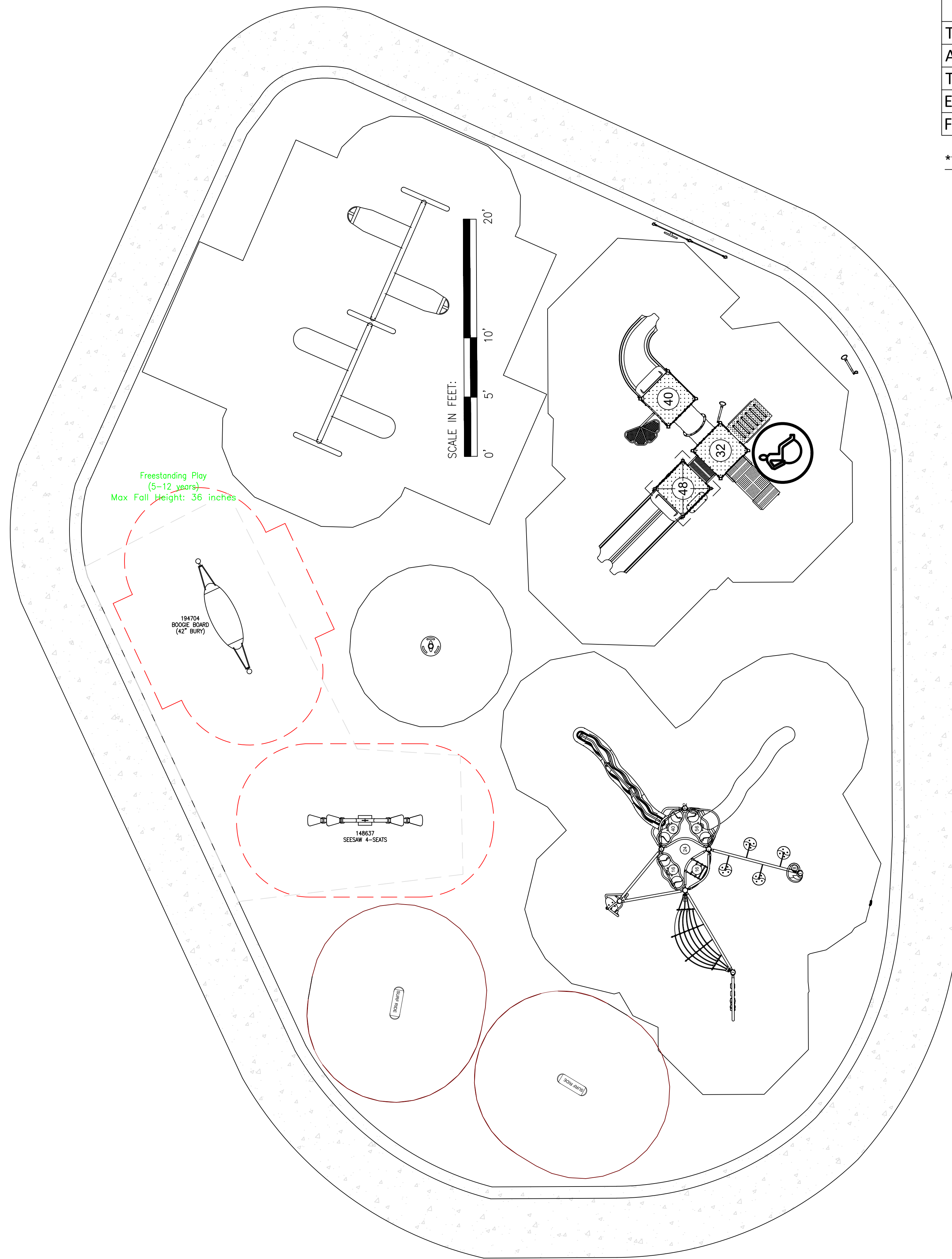

Freestanding Play
(5-12 years)
Max Fall Height: 36 inches

144704
BOOGIE BOARD
(42' BUNT)

149637
SEESAW 4-SEATS

32

40

48



SCALE IN FEET:
0' 5' 10' 20'

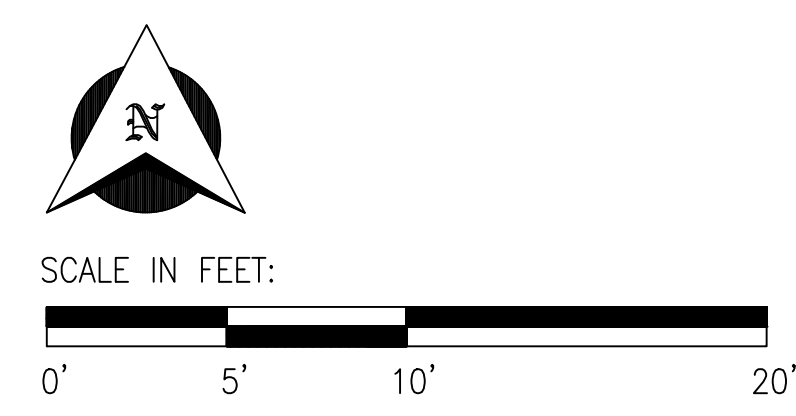

5-12 AREA (New equipment only)

TOTAL ELEVATED PLAY COMPONENTS	TBD		
TOTAL ELEVATED COMPONENTS ACCESSIBLE BY RAMP	0	REQUIRED	0
TOTAL ELEVATED COMPONENTS ACCESSIBLE BY TRANSFER	0	REQUIRED	0
TOTAL ACCESSIBLE GROUND LEVEL COMPONENTS SHOWN	2	REQUIRED	0
TOTAL DIFFERENT TYPES OF GROUND LEVEL COMPONENTS	2	REQUIRED	2



FLAGSHIP RECREATION
11123 UPPER 33RD ST N
LAKE ELMO, MN 55082
763-550-7860
FLAGSHIPPLAY.COM
@FLAGSHIPPLAY



THIS PLAY AREA & PLAY EQUIPMENT IS
DESIGNED FOR AGE RANGES AS NOTED
ON PLAN.

Dutch Knolls Park Option 3

21900 Elm Pkwy, Rogers, MN 55374

SALES REPRESENTATIVE:
Brett Altergott

DESIGNED BY:
JLZT
8/25/25

3/16" = 1'-0"

SHEET

LS101



LS landscape structures

Dutch Knoll Park - Opt 3

Rogers_DutchKnoll 082525 Opt3 • 8.25.2025



© 2025 Landscape Structures. All Rights Reserved

State Contract #218091



PROJECT INFORMATION

Dutch Knolls Park Opt 3

21900 Elm Pkwy

Rogers, MN 55374

Contract Year: 2025

EQUIPMENT INFORMATION & PRICING

<u>Qty</u>	<u>Item No.</u>	<u>Description</u>	<u>Price</u>	<u>Ext Price</u>
1	148637A	Seesaw 4-Seats DB	\$4,687	\$4,687.00
1	194704A	Boogie Board DB Only	\$3,335	\$3,335.00

Total Equipment Cost at State Contract Pricing

\$8,022.00



LS landscape
structures

Dutch Knoll Park 12.03.2025

Rogers_DutchKnoll 111425 • 12.3.2025



© 2025 Landscape Structures. All Rights Reserved



landscape structures

Dutch Knoll Park 12.03.2025

Rogers_DutchKnoll 111425 • 12.3.2025



© 2025 Landscape Structures. All Rights Reserved

State Contract #218091



PROJECT INFORMATION

Dutch Knolls Park

21900 Elm Pkwy

Rogers, MN 55374

Contract Year: 2026

EQUIPMENT INFORMATION & PRICING

<u>Qty</u>	<u>Item No.</u>	<u>Description</u>	<u>Price</u>	<u>Ext Price</u>
1	100046C	72"Wave Poly Slide DB	\$8,293	\$8,293.00
1	164075B	Double Bobble Rider DB	\$2,963	\$2,963.00
1	186490A	We-saw DB Only	\$15,193	\$15,193.00

Total Equipment Cost at State Contract Pricing

\$26,449.00



STAFF REPORT

ROGERS PARKS AND RECREATION ADVISORY COMMISSION

Meeting Date: December 11, 2025

Agenda Item: 6.3

Subject: Consider North Community Park Playground Options

Prepared By: Mike Bauer, Parks & Recreation Director

Overview / Background / Analysis

In November 2025, the City of Rogers issued a Request for Proposals (RFP) for the full replacement of the North Community Park (NCP) playground, including the conversion of the existing sand play area into a water misting feature.

The RFP identified the following project goals:

- All-inclusive \$1,000,000 turnkey budget, including equipment, installation, surfacing, drainage, and specialty features.
- Replace sand play with water misting elements designed for high-accessibility and low-water operation.
- Create a fully accessible playground, with primarily poured-in-place (PIP) rubber surfacing.
- Include:
 - 2–5-year-old play area
 - 5–12-year-old play area
 - Swings, including toddler, belt, inclusive, and/or adaptive seats
 - Shade elements
 - Multiple inclusive play features and ground-level access components

The RFP closed on December 8, 2025.

Four firms submitted six total design options. All proposals fit within the \$1M all-inclusive cap.

Design Considerations for Commission Review

Most Inclusive PIP Coverage

- St. Croix (Burke) – ~13,600 sq ft PIP
- Flagship Option 1 – 9,021 sq ft
- Flagship Option 2 – 8,603 sq ft

Requested Commission Action

The Parks & Recreation Department requests that the Commission:

1. Review all six submitted concepts
2. Select the finalist designs (2–3 recommended)
3. Direct staff to prepare:
 - Public engagement boards
 - Cost comparison summaries
 - Online engagement materials
4. Schedule a follow-up meeting for final design selection in early 2026.

Staff Recommendation

Financial Impact:

Source Fund:

Budgeted? Yes

Supporting Documentation

None



STAFF REPORT

ROGERS PARKS AND RECREATION ADVISORY COMMISSION

Meeting Date: December 11, 2025

Agenda Item: 6.4

Subject: Selection of Preliminary Design Sunnyside Park Playground Replacement

Prepared By: Mike Bauer, Parks & Recreation Director

Overview / Background / Analysis

The City issued an RFP in November 2025 to replace the Sunnyside Park playground within a **\$275,000–\$300,000 total budget**, requesting two concept types from vendors:

1. A design that retains the current layout but updates equipment, and
2. A design that reimagines or repurposes the play area.

Community feedback at the September meeting emphasized the desire for:

- A clubhouse or imaginative play structure
- A taller, two-story tower
- A climbing wall
- A longer zipline
- Bright, colorful designs (moving away from beige/green)
- A spinner or merry-go-round
- Shade elements
- Distinct 2–5 and 5–12 play zones
- Swings, including toddler, belt, and accessible seats

Four firms submitted a total of seven proposals by the December 8 deadline. Staff is asking the Commission to narrow the field to 2–3 finalists to bring forward for public engagement.

Comparison Summary

Vendor	Option	Notable Features	Estimated Total
Flagship	Opt 1	Netplex tower, ZipKrooz, spinners, music	\$302,244.36
Flagship	Opt 2	Lunar Burst tower, music, spinners	\$299,540.91
Midwest	Opt 1	Village-themed 2–5, climber-based 5–12	\$299,644.65
Midwest	Opt 2	Rope tower + mountain, LiveWire zipline	\$299,782.57
MWP/GameTime	Opt 1	Spire tower + 2–5 unit + zip track	\$275,000.00
MWP/GameTime	Opt 2	Alternative layout, similar amenities	\$300,000.00
St. Croix (Burke)	Opt 1	Evolution tower, climbers, slides	\$299,270.00

Next Steps – Commission Requested Action

Staff requests the Commission to:

1. Review all seven proposals using the enclosed visuals and summaries.
2. Select 2–3 finalists based on:
 - Play value
 - Age-zone separation
 - Inclusivity
 - Maintenance considerations
 - Vandalism resistance
 - Community fit
3. Direct staff to prepare public engagement materials (renderings, surveys, comparison boards).
4. Schedule finalist review for a future Commission meeting.

Staff Recommendation

Financial Impact:

Source Fund:

Budgeted? Yes

Supporting Documentation

- A. Flag Ship Preliminary Design & Budget_Sunny Side_Opt1_12-10-25
- B. Flagship Preliminary Design & Budget_Sunny Side_Opt2_12-10-25
- C. Midwest Playscapes OP1 Proposal - Sunnyside Park - Rogers, MN
- D. Midwest Playscapes OP2 Proposal - Sunnyside Park - Rogers, MN
- E. Minnesota Wisconsin Playground Sunnyside 1
- F. Minnesota Wisconsin Playground Sunnyside 2
- G. Sunnyside Park Playground Proposal St Croix Recreation

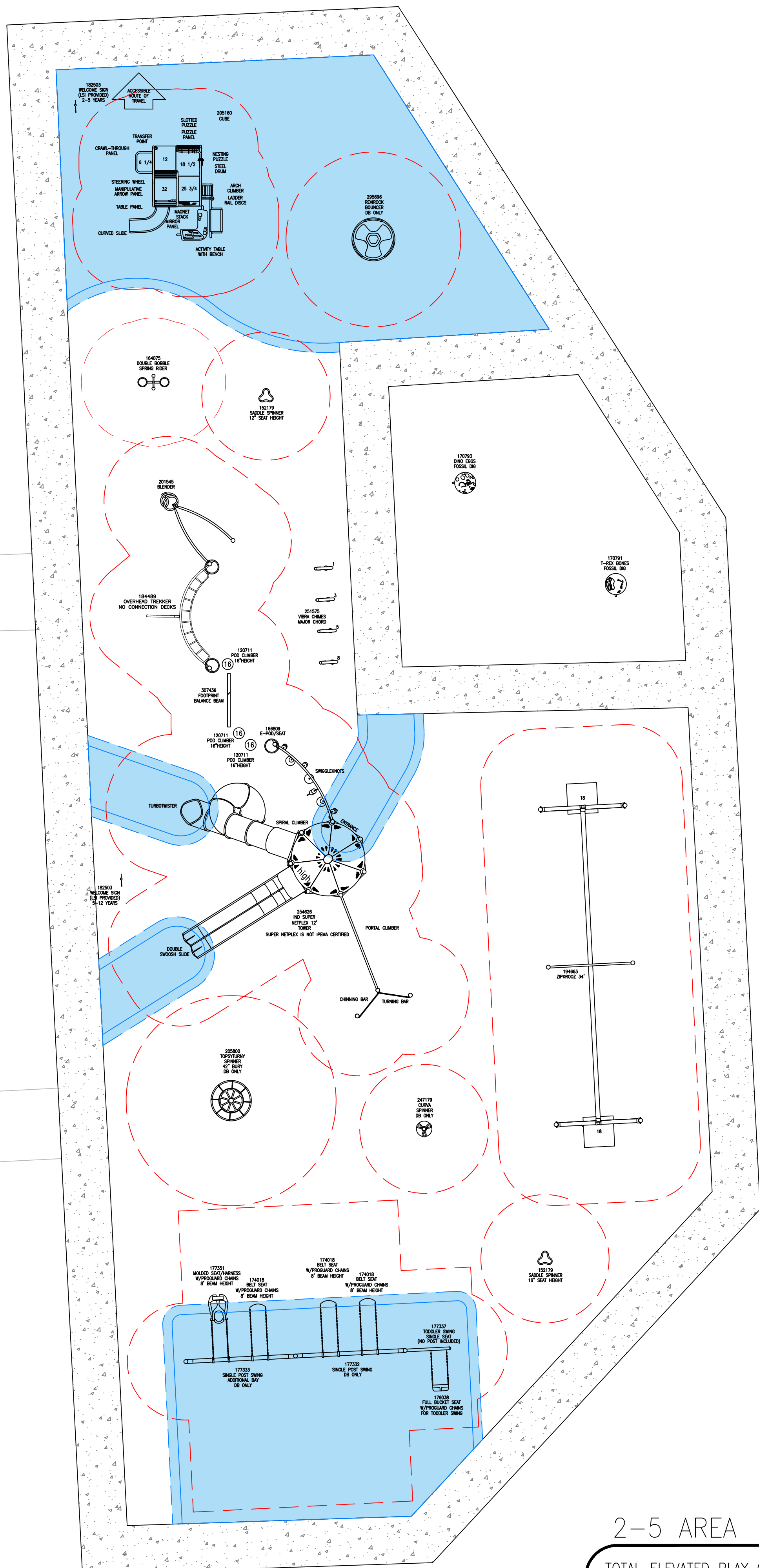

CONTAINER DETAILS

TOTAL MAIN CONTAINER AREA	7290 SF
TOTAL SAND CONTAINER AREA	829 SF
ASTM SAFETY SURFACING TYPE	ENGINEERED WOOD FIBER & PIP
TOTAL PIP AREA	2260 SF
TOTAL EWF AREA	5030 SF
EDGING TYPE	EXISTING CONCRETE WALK
FINISH GRADE	TOP OF CONCRETE WALK
MAX FALL HEIGHT (5-12 YR)	144"
MAX FALL HEIGHT (2-5 YR)	32"

*SITE PREPARATION REQUIREMENTS:

- Owner to provide a minimum 6' wide approved site access path to container and protection of this access route.
- Playground plan is based on ideal soil conditions. If there are concerns about the soils being suitable, it is recommended that the owner provide a geotechnical report of the site.
- Maximum of 1% grade change across the container.
- Owner installed drain tile to be within 4' of container perimeter.
- Drain tile installed by Flagship Recreation accounts for water within the container and does not account for run off from the surrounding flatwork, landscaping, buildings, etc.
- If owner installed border, drain tile stub to be provided.
- Owner to provide an accessible route to container.
- Minimum container size needed denotes the inside of the curb dimension.

2-5 AREA

TOTAL ELEVATED PLAY COMPONENTS	9		
TOTAL ELEVATED COMPONENTS ACCESSIBLE BY RAMP	0	REQUIRED	0
TOTAL ELEVATED COMPONENTS ACCESSIBLE BY TRANSFER	9	REQUIRED	5
TOTAL ACCESSIBLE GROUND LEVEL COMPONENTS SHOWN	8	REQUIRED	3
TOTAL DIFFERENT TYPES OF GROUND LEVEL COMPONENTS	7	REQUIRED	7

5-12 AREA

TOTAL ELEVATED PLAY COMPONENTS	3		
TOTAL ELEVATED COMPONENTS ACCESSIBLE BY RAMP	0	REQUIRED	0
TOTAL ELEVATED COMPONENTS ACCESSIBLE BY TRANSFER	3	REQUIRED	2
TOTAL ACCESSIBLE GROUND LEVEL COMPONENTS SHOWN	17	REQUIRED	1
TOTAL DIFFERENT TYPES OF GROUND LEVEL COMPONENTS	6	REQUIRED	6



FLAGSHIP RECREATION
 11123 UPPER 33RD ST N
 LAKE ELMO, MN 55082
 763-550-7860
 FLAGSHIPPLAY.COM



THIS PLAY AREA AND PLAY EQUIPMENT IS DESIGNED FOR AGE RANGES AS NOTED ON PLAN.

THIS DESIGN CONFORMS TO THE ADA ACCESSIBILITY GUIDELINES (ADAAG), ASSUMING THAT THE ENTIRE USE ZONE IS COVERED WITH AN ACCESSIBLE PROTECTIVE SURFACING, UNLESS OTHERWISE NOTED ON THE PLAN.

SUNNY SIDE PARK OPTION 1

22184 138th Ave N, Rogers, MN 55374

SALES REPRESENTATIVE:
Brett Altergott

DESIGNED BY:
JLZT
12/3/25

1/8" = 1'-0"

SHEET
LS101

C:\Users\lauri\Thuberg\Flagship Recreation - document\2026 Planning\Brett\Wogers_Sunny Side Park\2025.12.03 Prelim Design\Opt 1\Wogers_SunnySide 202525 Opt1.dwg

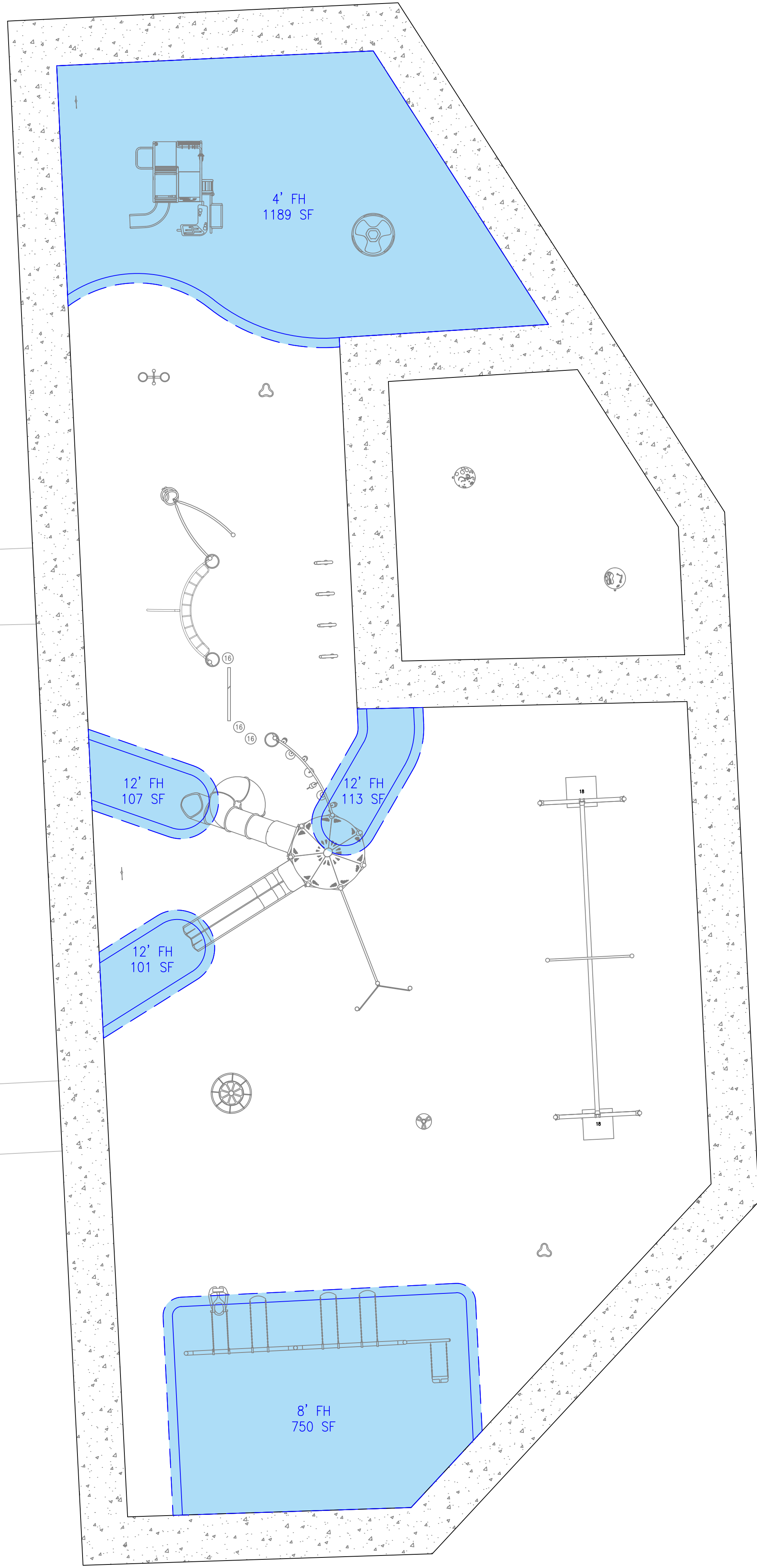

POURED-IN-PLACE DETAILS	
TOTAL AREA	7290 SF
PIP BY CRITICAL FALL HEIGHTS	SQ FT
4' CFH PIP	1189
8' CFH PIP	750
12' CFH PIP	321
TOTAL PIP	2260
PIP BY COLOR	
50% COLOR 1 / 50% BLACK	2260
TOTAL PIP	2260



FLAGSHIP RECREATION
 11123 UPPER 33RD ST N
 LAKE ELMO, MN 55082
 763-550-7860
 FLAGSHIPPLAY.COM



THIS PLAY AREA AND PLAY EQUIPMENT IS DESIGNED FOR AGE RANGES AS NOTED ON PLAN.

THIS DESIGN CONFORMS TO THE ADA ACCESSIBILITY GUIDELINES (ADAAG), ASSUMING THAT THE ENTIRE USE ZONE IS COVERED WITH AN ACCESSIBLE PROTECTIVE SURFACING, UNLESS OTHERWISE NOTED ON THE PLAN.

Sunny Side Park - Opt 1
SAFETY SURFACING HOLD
DOWN'S & DESIGN
 22184 138th Ave N, Rogers, MN 55374



SALES REPRESENTATIVE:
Brett Altergott

DESIGNED BY:
 JLZT
 12/3/25

1/8" = 1'-0"



SHEET
LG101



 **Sunny Side Park - Opt 1**
Rogers_SunnySide 120325 Opt1 • 12.3.2025 

© 2025 Landscape Structures. All Rights Reserved

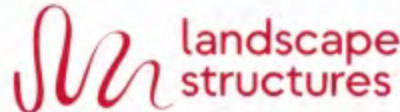

 **Sunny Side Park - Opt 1**
Rogers_SunnySide 120325 Opt1 • 12.3.2025 
© 2025 Landscape Structures. All Rights Reserved



ls landscape structures



Sunny Side Park - Opt 1

Rogers_SunnySide 120325 Opt1 • 12.3.2025



© 2025 Landscape Structures. All Rights Reserved



 **Sunny Side Park - Opt 1**
Rogers_SunnySide 120325 Opt1 • 12.3.2025 

© 2025 Landscape Structures. All Rights Reserved





Sunny Side Park - Opt 1

Rogers_SunnySide 120325 Opt1 • 12.3.2025



© 2025 Landscape Structures. All Rights Reserved





 **Sunny Side Park - Opt 1**
Rogers_SunnySide 120325 Opt1 • 12.3.2025 

© 2025 Landscape Structures. All Rights Reserved



 **Sunny Side Park - Opt 1**
Rogers_SunnySide 120325 Opt1 • 12.3.2025 
© 2025 Landscape Structures. All Rights Reserved



 **Sunny Side Park - Opt 1**
Rogers_SunnySide 120325 Opt1 • 12.3.2025 

© 2025 Landscape Structures. All Rights Reserved

State Contract #218091



PROJECT INFORMATION

Sunny Side Park - Opt 1

22184 138th Ave N

Rogers, MN 55374

Contract Year: 2026

EQUIPMENT INFORMATION & PRICING

<u>Qty</u>	<u>Item No.</u>	<u>Description</u>	<u>Price</u>	<u>Ext Price</u>
1	111404F	108"Alum Post DB	\$423	\$423.00
1	111404H	92"Alum Post DB	\$398	\$398.00
2	111404O	132"Steel Post DB	\$423	\$846.00
1	166809A	E-Pod Seat	\$444	\$444.00
1	184489C	Overhead Trekker Ladder w/o Deck Connections DB	\$3,499	\$3,499.00
1	201545A	Blender Spinner DB	\$3,575	\$3,575.00
1	205160A	Cube DB	\$21,446	\$21,446.00
1	307436A	Footprint Balance Beam DB	\$627	\$627.00
3	120711A	Pod Climber 16" DB	\$403	\$1,209.00
1	152179A	Saddle Spinner DB 12"Height	\$1,010	\$1,010.00
1	152179A	Saddle Spinner DB 16"Height	\$1,010	\$1,010.00
1	164075B	Double Bobble Rider DB	\$2,963	\$2,963.00
1	170791A	T-Rex Bones Fossil Dig	\$862	\$862.00
1	170793A	Dino Egg Fossil Dig	\$862	\$862.00
3	174018A	Belt Seat ProGuard Chains for 8' Beam Height	\$179	\$537.00
1	176038G	Full Bucket Seat ProGuard Chains for Toddler Swing	\$495	\$495.00
1	177332A	Single Post Swing Frame 8' Beam Height Only DB Only	\$1,744	\$1,744.00
1	177333A	Single Post Swing Frame Additional Bay 8' Beam Height Only DB Or	\$1,295	\$1,295.00
1	177337A	Toddler Swing Add-On Beam	\$719	\$719.00
1	177351A	Molded Bucket Seat (5-12 yrs) w/Harness ProGuard Chains for 8' B	\$1,219	\$1,219.00
1	194663A	ZipKrooz 34' w/Aluminum Posts DB	\$17,039	\$17,039.00
1	205800A	TopsyTurny Spinner 42"Bury DB Only	\$7,074	\$7,074.00
1	247179A	Curva Spinner DB Only	\$2,683	\$2,683.00
1	251575A	Rhapsody Vibra Chimes Major Chord DB	\$5,967	\$5,967.00
1	254626A	Super Netplex 12' Tower	\$110,140	\$110,140.00
1	295696A	ReviRock Bouncer DB Only	\$6,212	\$6,212.00
1	182503A	Welcome Sign (LSI Provided) Ages 2-5 years Direct Bury	\$0	\$0.00
1	182503C	Welcome Sign (LSI Provided) Ages 5-12 years Direct Bury	\$0	\$0.00

Total Equipment Cost at State Contract Pricing

\$194,298.00



City of Rogers
 22350 S. Diamond Lake Rd.
 Rogers, MN 55374
 Mike Bauer - Parks & Recreation Director

PRELIMINARY BUDGET - THIS IS AN ESTIMATE & NOT A FORMAL QUOTE

	Preliminary Budget	Possible Additions	Possible Reductions	QTY	Notes
Play Equipment					
Sunny Side Park - Opt 1, BA702SSP811946001	194,298.00				2026 State Contract Price
State Contract #218091	(15,543.84)			8%	(6% discount under \$80,000 & 8% discount \$80,000 & above)
Sales Tax - if applicable	0.00				ST3 Certificate of Exemption must be provided by owner.
Delivery of Play equipment	1,800.00				Estimated / Final quote will be provided upon final design.
Mobilization	750.00				Mobilization of Installation Crew to Job Site (Trailer Skid Steer Augur, Tools, Mixer, Etc.)
Dumpster(s) - 30 Yard	750.00				Disposal of packaging material - Deduct if Provided by Owner/Volunteers
Site work					
Demo of Existing Equipment & Excavation (existing container)	City of Rogers			0	Removal of Existing Equip & Excavation of Surfacing - Deduct if Provided by Owner/Volunteers
Border Options	Keep Existing				
Equipment Installation (Labor & Concrete for Footings)	36,953.32			20.67%	Full professional installation by Landscape Structures Certified Installers. Standard labor rate unless otherwise noted
Lift Rental	1,942.31				Lift required for assembly of the Super Netplex.
Subgrade Prep & Engineered Wood Fiber Surfacing (EWF)					
Geotextile Fabric (Sq. Ft.)	2,515.00			5,030	Materials & Install Unless Noted - <i>Installed AFTER Drainage Agg & Tile</i> - Deduct if by Owner/Volunteers
EWF - Playground Safety Surfacing (CY)	9,810.00			218	IPEMA Certified Meets ASTM, ADA & CPSC - <i>Installed AFTER Fabric</i> - Deduct INSTALL LABOR if by Owner/Volunteers
EWF Freight	1,200.00				
Rubber Wear Mats	0.00			0	Rubber Wear Mats - Installed AFTER Playground Wood Fiber - Deduct INSTALL LABOR if Completed by Owner/Volunteers
Subgrade Prep & Poured In Place (PIP) or Turf Surfacing					
Compacted Aggregate Base (Recycled Concrete or Class 5) (Tons)	5,876.77			88	Class 5 Agg w/ Fines or Recycled Concrete, Material & Install 4" - 6" Compacted Required for PIP & Turf Installations
Drain Tile (LF)	7,110.40			440	Wrapped w/ Clear Agg - Drain Stubs Req'd Inside Container. Improper Drainage Will Cause PIP to Fail and is NOT Warrantied.
Poured In Place Rubber Surfacing (Sq. Ft.)	54,782.40			2,260	ESTIMATED 50/50 mix of Standard Colors/Black Speckled (Designs & Premium Colors Extra)
Chain Link Construction Fence (8' x 8' Panels)	0.00			0	Temporary Construction Fence, Locked Gate, Traffic Control - Cones, Signage, etc. Not Included
Security Guard	0.00				24 Hr Site Security req'd during Installation & Cure Time. Cure Times vary with weather and thickness. Defects or damage due to trespass before sufficient cure time will not be covered by warranty. Flagship Rec not licensed for Security Services.
Site Restoration (Sq.Ft.)	City of Rogers			0	Backfilling Req'd to Stabilize Border - Not Responsible for "Movement" - Not Included
Payment & Performance Bonds	6,359.02		(6,359.02)		Included By Request
	Preliminary Total	Additions Total	Reductions Total		Total w/ Additions & Reductions
	308,603.38	0.00	(6,359.02)		302,244.36

C:\Users\jau\thunder\Flagship Recreation - Documents\2026 Planning\Brett\Flagship_Sunny Side Park\2025\2.03 Prelim Design\Opt 2\Flagship_SunnySide 100325 Opt2.dwg

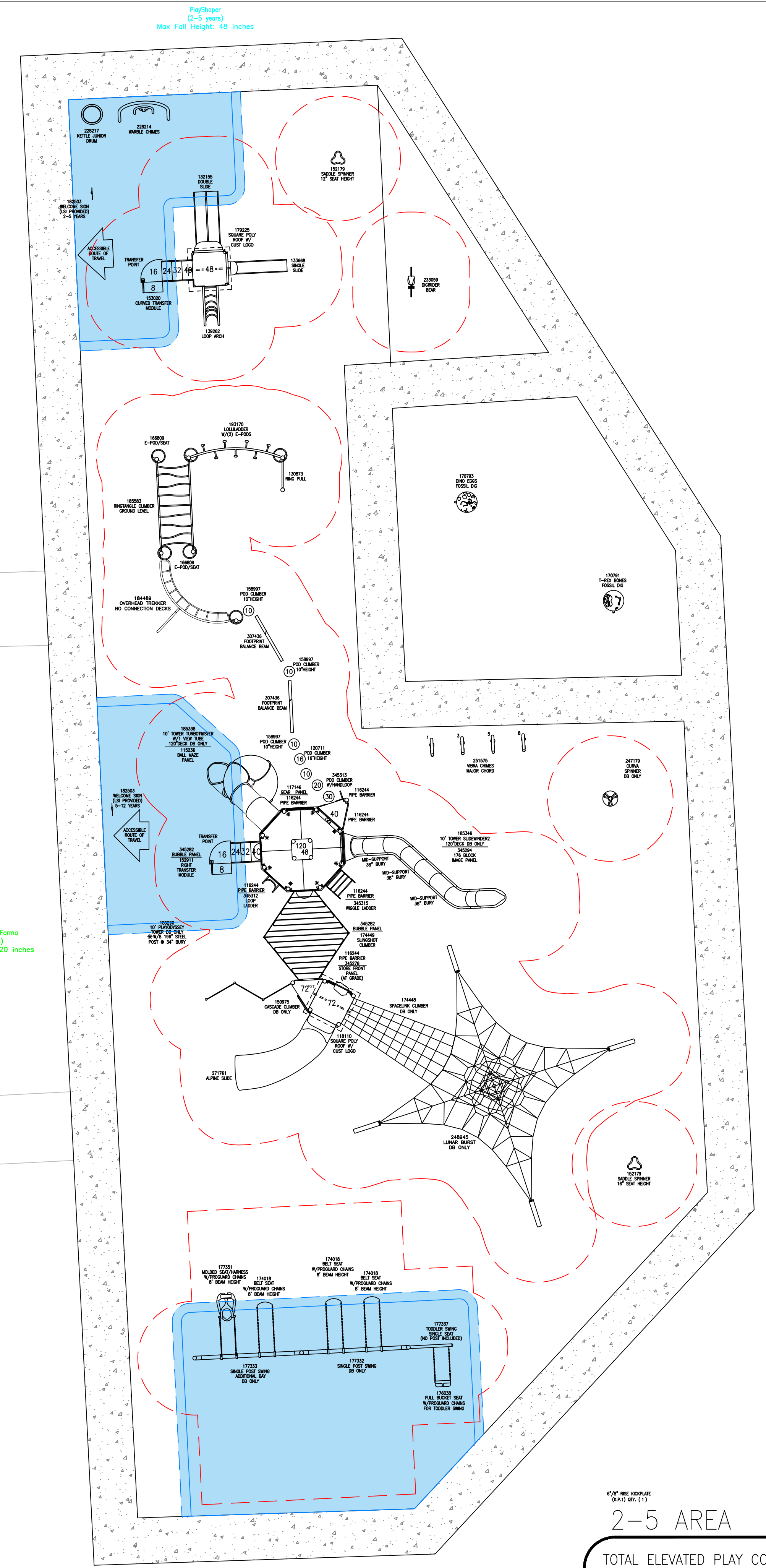

Playbooster and Forms
(5-12 years)
Max Fall Height: 120 inches

PlayShaper
(2-5 years)
Max Fall Height: 48 inches

2-5 AREA

TOTAL ELEVATED PLAY COMPONENTS	3		
TOTAL ELEVATED COMPONENTS ACCESSIBLE BY RAMP	0	REQUIRED	0
TOTAL ELEVATED COMPONENTS ACCESSIBLE BY TRANSFER	3	REQUIRED	2
TOTAL ACCESSIBLE GROUND LEVEL COMPONENTS SHOWN	3	REQUIRED	1
TOTAL DIFFERENT TYPES OF GROUND LEVEL COMPONENTS	3	REQUIRED	3

5-12 AREA

TOTAL ELEVATED PLAY COMPONENTS	14		
TOTAL ELEVATED COMPONENTS ACCESSIBLE BY RAMP	0	REQUIRED	0
TOTAL ELEVATED COMPONENTS ACCESSIBLE BY TRANSFER	7	REQUIRED	7
TOTAL ACCESSIBLE GROUND LEVEL COMPONENTS SHOWN	17	REQUIRED	5
TOTAL DIFFERENT TYPES OF GROUND LEVEL COMPONENTS	7	REQUIRED	7

CONTAINER DETAILS

TOTAL MAIN CONTAINER AREA	7290 SF
TOTAL SAND CONTAINER AREA	829 SF
ASTM SAFETY SURFACING TYPE	ENGINEERED WOOD FIBER & PIP
TOTAL PIP AREA	1515 SF
TOTAL EWF AREA	5775 SF
EDGING TYPE	EXISTING CONCRETE WALK
FINISH GRADE	TOP OF CONCRETE WALK
MAX FALL HEIGHT (5-12 YR)	120"
MAX FALL HEIGHT (2-5 YR)	48"

*SITE PREPARATION REQUIREMENTS:

- Owner to provide a minimum 6' wide approved site access path to container and protection of this access route.
- Playground plan is based on ideal soil conditions. If there are concerns about the soils being suitable, it is recommended that the owner provide a geotechnical report of the site.
- Maximum of 1% grade change across the container.
- Owner installed drain tile to be within 4' of container perimeter.
- Drain tile installed by Flagship Recreation accounts for water within the container and does not account for run off from the surrounding flatwork, landscaping, buildings, etc.
- If owner installed border, drain tile stub to be provided.
- Owner to provide an accessible route to container.
- Minimum container size needed denotes the inside of the curb dimension.



FLAGSHIP RECREATION
11123 UPPER 33RD ST N
LAKE ELMO, MN 55082
763-550-7860
FLAGSHIPPLAY.COM

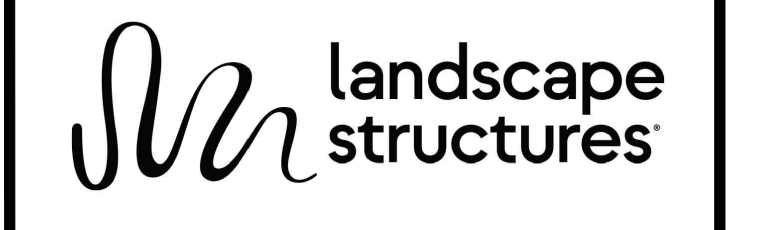

THIS PLAY AREA AND PLAY EQUIPMENT IS DESIGNED FOR AGE RANGES AS NOTED ON PLAN.

THIS DESIGN CONFORMS TO THE ADA ACCESSIBILITY GUIDELINES (ADAAG), ASSUMING THAT THE ENTIRE USE ZONE IS COVERED WITH AN ACCESSIBLE PROTECTIVE SURFACING, UNLESS OTHERWISE NOTED ON THE PLAN.

SUNNY SIDE PARK
OPTION 2

22184 138th Ave N, Rogers, MN 55374

SALES REPRESENTATIVE:
Brett Altergott

DESIGNED BY:
JLZT
12/3/25

1/8" = 1'-0"

SHEET
LS101

C:\Users\lauri\Thumbnails\Flagship Recreation - Document\2025\2025 Prelim Design\Opt 2\Flagship_SunnySide_202525_Opt2.dwg

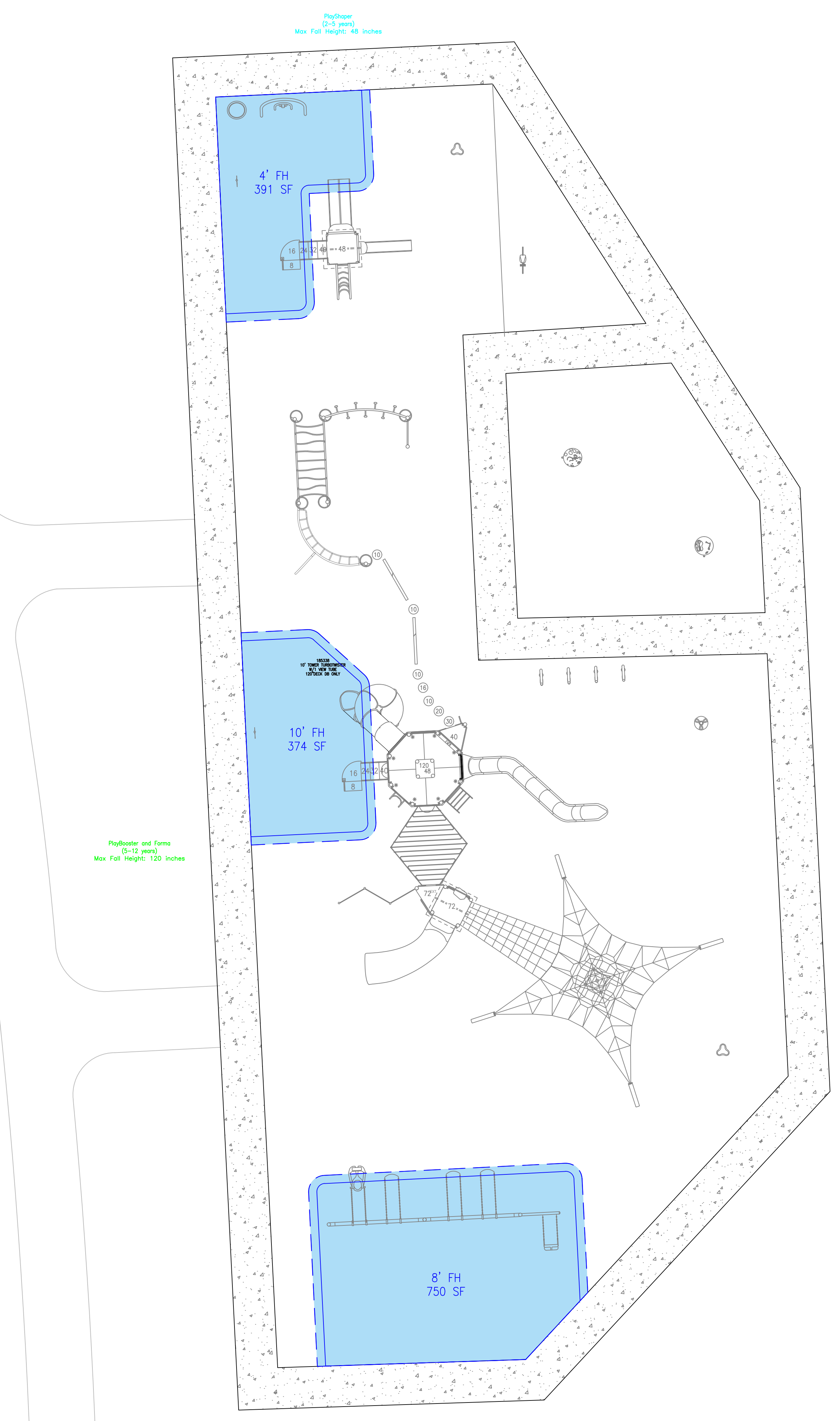

POURED-IN-PLACE DETAILS		
TOTAL AREA		7290 SF
PIP BY CRITICAL FALL HEIGHTS		SQ FT
	4' CFH PIP	391
	8' CFH PIP	750
	10' CFH PIP	374
	TOTAL PIP	1515
PIP BY COLOR		
	50% COLOR 1 / 50% BLACK	2260
	TOTAL PIP	2260



FLAGSHIP RECREATION
 11123 UPPER 33RD ST N
 LAKE ELMO, MN 55082
 763-550-7860
 FLAGSHIPPLAY.COM



THIS PLAY AREA AND PLAY EQUIPMENT IS DESIGNED FOR AGE RANGES AS NOTED ON PLAN.

THIS DESIGN CONFORMS TO THE ADA ACCESSIBILITY GUIDELINES (ADAAG), ASSUMING THAT THE ENTIRE USE ZONE IS COVERED WITH AN ACCESSIBLE PROTECTIVE SURFACING, UNLESS OTHERWISE NOTED ON THE PLAN.

Sunny Side Park - Opt 2
SAFETY SURFACING HOLD
DOWNES & DESIGN
 22184 138th Ave N, Rogers, MN 55374



SALES REPRESENTATIVE:
Brett Altergott

DESIGNED BY:
 JLZT
 12/3/25

1/8" = 1'-0"



SHEET
LG101



 **Sunny Side Park - Opt 2**
Rogers_SunnySide 120325 Opt2 • 12.3.2025 



© 2025 Landscape Structures. All Rights Reserved



 **Sunny Side Park - Opt 2**
Rogers_SunnySide 120325 Opt2 • 12.3.2025 

© 2025 Landscape Structures. All Rights Reserved



 **Sunny Side Park - Opt 2**
Rogers_SunnySide 120325 Opt2 • 12.3.2025 
© 2025 Landscape Structures. All Rights Reserved



 **Sunny Side Park - Opt 2**
Rogers_SunnySide 120325 Opt2 • 12.3.2025 

© 2025 Landscape Structures. All Rights Reserved





Sunny Side Park - Opt 2

Rogers_SunnySide 120325 Opt2 • 12.3.2025



© 2025 Landscape Structures. All Rights Reserved



 **Sunny Side Park - Opt 2**
Rogers_SunnySide 120325 Opt2 • 12.3.2025 

© 2025 Landscape Structures. All Rights Reserved



Sunny Side Park - Opt 2

Rogers_SunnySide 120325 Opt2 • 12.3.2025



© 2025 Landscape Structures. All Rights Reserved



SUNNY SIDE PARK

landscape structures

Sunny Side Park - Opt 2

Rogers_SunnySide 120325 Opt2 • 12.3.2025



© 2025 Landscape Structures. All Rights Reserved



PROJECT INFORMATION

Sunny Side Park - Opt 2

22184 138th Ave N

Rogers, MN 55374

Contract Year: 2026

EQUIPMENT INFORMATION & PRICING

<u>Qty</u>	<u>Item No.</u>	<u>Description</u>	<u>Price</u>	<u>Ext Price</u>
1	111228A	Square Tenderdeck	\$1,474	\$1,474.00
1	111231A	Triangular Tenderdeck	\$1,137	\$1,137.00
1	111237A	Square Tenderdeck	\$1,117	\$1,117.00
4	111396B	137"Post For Roof DB	\$510	\$2,040.00
4	111403V	190"Steel Post For Roof DB	\$627	\$2,508.00
1	111404A	148"Alum Post DB	\$566	\$566.00
3	111404E	116"Alum Post DB	\$444	\$1,332.00
3	111404F	108"Alum Post DB	\$423	\$1,269.00
2	111404H	92"Alum Post DB	\$398	\$796.00
1	115236A	Ball Maze Panel Above Deck	\$1,760	\$1,760.00
6	116244A	Pipe Barrier Above Deck	\$893	\$5,358.00
1	117146A	Gear Panel Above Deck	\$2,769	\$2,769.00
1	118110A	Square Poly Roof Custom Logo Panels	\$1,846	\$1,846.00
1	119646A	Tri-Deck Extension	\$1,102	\$1,102.00
1	121948A	Kick Plate 8"Rise	\$163	\$163.00
1	130873A	Ring Pull	\$944	\$944.00
1	132155B	Double Slide 48"Dk DB	\$2,958	\$2,958.00
1	133668A	Single Slide 48"Dk DB	\$2,239	\$2,239.00
1	139262A	Loop Arch 48"Dk DB	\$1,897	\$1,897.00
1	150975B	Cascade Climber 72"Dk DB Only	\$4,432	\$4,432.00
1	152911C	Curved Transfer Module Right 48"Dk DB	\$4,177	\$4,177.00
1	153020C	Curved Transfer Module 48"Dk Right DB	\$3,830	\$3,830.00
2	166809A	E-Pod Seat	\$444	\$888.00
1	174448A	SpaceLink Climber to 72" Deck Attached to Square Deck	\$8,548	\$8,548.00
1	174449A	Sling Shot Climber 48"DK DB	\$4,483	\$4,483.00
1	179225A	Square Poly Roof Custom Logo Panels	\$1,846	\$1,846.00
1	184489C	Overhead Trekker Ladder w/o Deck Connections DB	\$3,499	\$3,499.00
1	185296A	10' PlayOdyssey Tower	\$39,341	\$39,341.00
1	185338B	10' Tower TurboTwister w/1 View	\$10,073	\$10,073.00
1	185346A	10' Tower SlideWinder2	\$7,951	\$7,951.00
1	185583A	Ring Tangle Climber Ground Level	\$2,382	\$2,382.00
1	193170A	LolliLadder w/2 E-Pods	\$3,611	\$3,611.00

1	271761A	Alpine Slide 72" Deck DB	\$5,523	\$5,523.00
2	307436A	Footprint Balance Beam DB	\$627	\$1,254.00
1	345276A	Storefront Panel	\$893	\$893.00
2	345282A	Bubble Panel Above Deck	\$1,214	\$2,428.00
1	345294A	Image Panel - 176 Block Above Deck	\$2,009	\$2,009.00
1	345312A	Loop Ladder 48"Dk DB	\$1,331	\$1,331.00
1	345313B	Pod Climber w/Handloop 40"Dk DB Right Handhold	\$2,071	\$2,071.00
1	345315C	Wiggle Ladder 48"Dk DB	\$1,091	\$1,091.00
1	120711A	Pod Climber 16" DB	\$403	\$403.00
1	152179A	Saddle Spinner DB 12"Height	\$1,010	\$1,010.00
1	152179A	Saddle Spinner DB 16"Height	\$1,010	\$1,010.00
3	158997A	Pod Climber 10" DB	\$398	\$1,194.00
1	170791A	T-Rex Bones Fossil Dig	\$862	\$862.00
1	170793A	Dino Egg Fossil Dig	\$862	\$862.00
3	174018A	Belt Seat ProGuard Chains for 8' Beam Height	\$179	\$537.00
1	176038G	Full Bucket Seat ProGuard Chains for Toddler Swing	\$495	\$495.00
1	177332A	Single Post Swing Frame 8' Beam Height Only DB Only	\$1,744	\$1,744.00
1	177333A	Single Post Swing Frame Additional Bay 8' Beam Height Only DB Or	\$1,295	\$1,295.00
1	177337A	Toddler Swing Add-On Beam	\$719	\$719.00
1	177351A	Molded Bucket Seat (5-12 yrs) w/Harness ProGuard Chains for 8' B	\$1,219	\$1,219.00
1	228214A	Rhapsody Warble Chimes DB	\$6,712	\$6,712.00
1	228217A	Rhapsody Kettle Drum Junior DB	\$2,015	\$2,015.00
1	233059B	DigiRider Bear DB	\$1,958	\$1,958.00
1	247179A	Curva Spinner DB Only	\$2,683	\$2,683.00
1	248945A	Lunar Burst DB Only	\$29,927	\$29,927.00
1	251575A	Rhapsody Vibra Chimes Major Chord DB	\$5,967	\$5,967.00
1	182503A	Welcome Sign (LSI Provided) Ages 2-5 years Direct Bury	\$0	\$0.00
1	182503C	Welcome Sign (LSI Provided) Ages 5-12 years Direct Bury	\$0	\$0.00

Total Equipment Cost at State Contract Pricing

\$205,548.00



City of Rogers
 22350 South Diamond Lake Road
 Rogers, MN 55374
 Director/Principal

PRELIMINARY BUDGET - THIS IS AN ESTIMATE & NOT A FORMAL QUOTE

	Preliminary Budget	Possible Additions	Possible Reductions	QTY	Notes
Play Equipment					
Sunny Side Park - Opt 2,BA702SSP811946001	205,548.00				2026 State Contract Price
State Contract #218091	(16,443.84)			8%	(6% discount under \$80,000 & 8% discount \$80,000 & above)
Sales Tax - if applicable	0.00				ST3 Certificate of Exemption must be provided by owner.
Delivery of Play equipment	1,800.00				Estimated / Final quote will be provided upon final design.
Mobilization	750.00				Mobilization of Installation Crew to Job Site (Trailer Skid Steer Augur, Tools, Mixer, Etc.)
Dumpster(s) - 30 Yard	750.00				Disposal of packaging material - Deduct if Provided by Owner/Volunteers
Site work					
Demo of Existing Equipment & Excavation (existing container)	City of Rogers			0	Removal of Existing Equip & Excavation of Surfacing - Deduct if Provided by Owner/Volunteers
Border Options	Keep Existing				
Equipment Installation (Labor & Concrete for Footings)	39,032.91			20.64%	Full professional installation by Landscape Structures Certified Installers. Standard labor rate unless otherwise noted
Lift Rental	1,942.31				Lift rental needed for assembly of tower
Subgrade Prep & Engineered Wood Fiber Surfacing (EWF)					
Geotextile Fabric (Sq. Ft.)	2,887.50			5,775	Materials & Install Unless Noted - <i>Installed AFTER Drainage Agg & Tile</i> - Deduct if by Owner/Volunteers
EWF - Playground Safety Surfacing (CY)	11,250.00			250	IPEMA Certified Meets ASTM, ADA & CPSC - <i>Installed AFTER Fabric</i> - Deduct INSTALL LABOR if by Owner/Volunteers
EWF Freight	1,200.00				
Subgrade Prep & Poured In Place (PIP) or Turf Surfacing					
Compacted Aggregate Base (Recycled Concrete or Class 5) (Tons)	3,929.73			59	Class 5 Agg w/ Fines or Recycled Concrete, Material & Install 4" - 6" Compacted Required for PIP & Turf Installations
Concrete Base / mound or sloped surface (2" skim coat)	0.00			0	Concrete Skim Coating Req'd for PIP/Turf Subbase on Surfaces that are not Flat.
Drain Tile (LF)	7,110.40			440	Wrapped w/ Clear Agg - Drain Stubs Req'd Inside Container. Improper Drainage Will Cause PIP to Fail and is NOT Warrantied.
Poured In Place Rubber Surfacing (Sq. Ft.)	39,783.90			1,515	ESTIMATE 50/50 mix of Standard Colors/Black Speckled (Designs & Premium Colors Extra)
Chain Link Construction Fence (8' x 8' Panels)	0.00			0	Temporary Construction Fence, Locked Gate, Traffic Control - Cones, Signage, etc. Not Included
Security Guard	0.00				24 Hr Site Security req'd during Installation & Cure Time. Cure Times vary with weather and thickness. Defects or damage due to trespass before sufficient cure time will not be covered by warranty. Flagship Rec not licensed for Security Services.
Site Restoration (Sq.Ft.)	City of Rogers			0	Backfilling Req'd to Stabilize Border - Not Responsible for "Movement" - Not Included
Payment & Performance Bonds	6,122.66		(6,122.66)		Included By Request
	Preliminary Total	Additions Total	Reductions Total		Total w/ Additions & Reductions
	305,663.57	0.00	(6,122.66)		299,540.91

City of Rogers, MN

SUNNYSIDE PARK

MIDWEST PLAYSCAPES | PLAYGROUND REPLACEMENT

PROPOSAL - OPTION 1



PROPOSAL BY:

PREPARED FOR:



Tim Solomonson | PLA(MN) | CPSI
Project Manager | Architectural Liaison



TOLL FREE: 1-800-747-1452
Info@MidwestPlayscapes.com
8632 Eagle Creek Circle
Savage, MN 55378



TO: Mike Bauer | Parks and Recreation Director

DATE: Dec 8, 2025

Dear Mr. Bauer,

We are pleased to present three playground proposal options, each with unique themes, materials, and experiences, for Sunnyside Park in Rogers, MN. Our proposals will provide a turn-key playground installation for children ages 2-12 with an emphasis on inclusive and accessible ground-level and elevated play features supported by resilient rubber safety surfacing, shade, and a cooling focused misting water feature.

Each proposal option can be selected as-is, but our recommendation for a project of this scale and importance would be to work closely with the Parks and Recreation Commission and key city staff, if awarded, to develop a fully tailored playground solution that meets the needs of residents and operations and maintenance considers of the City while remaining under budget. We believe in a collaborative design approach on our projects and our team of Landscape Architects and designers understand the significance of this investment for the City. We want to ensure the final design creates the best possible outcomes for the City's residents and would welcome feedback and modifications to the design if desired.

All of our designs include:

- A 2-5 playground with swings, rockers, spinners, climbers and inclusive ground level and elevated features
- A 5-12 playground with swings, zipline, rockers, spinners, climbers and inclusive ground level and elevated features
- Shaded care giver seating
- A rubber safety surface system that links to key feature entry, exit, and wear points, ensuring maximum access, safety, and inclusivity while working as an extension of the play environment.
- All of the features meet all relevant ASTM and CPSC standards.

We take a lot of pride in delivering projects at the contracted price and will never request additional money for cost overruns should they occur. Longterm project outcomes and relationships are our priority. Our mission at Midwest Playscapes is to provide exciting, safe, and comfortable play environments for children of all ages and abilities.

We will be the sole point of contact for warranty and service requests should it be required and have dedicated warranty and service team to ensure the project is maintained to the highest standard throughout the life of the project and take a lot of pride in the longevity of our projects.

Thank you for your time and consideration.

With Gratitude,

A handwritten signature in black ink, appearing to read 'Tim Solomonson', is written over a white background.

Tim Solomonson | PLA(MN) | CPSI | Project Manager

QUOTATION - OPTION 1

Project:	Sunnyside Park Playground Replacement	Sourcewell Info:	Phone:	763-428-0974	
Contact:	Mike Bauer	Playworld Systems: #010521-LTS-8	Fax:		
Ship To:	22184 138th Ave N, Rogers, MN 55374		Bill To:		
Email:	mbauer@rogersmn.gov	Customer Name / Contract #:			
Shipping Contact:	tims@midwestplayscapes.com		Date:	12/8/25	
Qty	Design / Item	Description	Inclusive	Unit Price	Total
		<u>Border, Surfacing, and Site Work</u>			
1	NOT IN CONTRACT	Removals and Container Prep (By Owner)			
100	TON	Drainage Aggregate		\$ 45.00	\$4,500.00
200	LF	Drain tile		\$ 1.50	\$300.00
238.12	CY	Engineered Wood Fiber		\$ 25.00	\$5,953.00
2747	SF	Poured-in-place Rubber Safety Surface		\$ 18.69	\$51,341.43
2747	SF	Poured-in-place Aggregate Base		\$ 4.60	\$12,636.20
		<u>2-5 Play Equipment</u>			
1	ZZXX0880	Community Helper w/ Tunnel		\$ 23,112.00	\$23,112.00
1	ZZXX0882	Playtown Playhouse w/o Tunnel		\$ 14,343.00	\$14,343.00
1	350-2231	Challengers (Ages 2-5) (SALE ITEM)		\$ 12,784.00	\$12,784.00
1	ZZXX0483	Cozy Cocoon		\$ 4,531.00	\$4,531.00
1	ZZXX0843	Early Childhood Swing		\$ 2,348.00	\$2,348.00
		<u>5-12 Play Equipment</u>			
1	350-2535	Challengers (Ages 5-12)		\$ 78,500.00	\$78,500.00
1	ZZXX0600	Accessible Seesaw		\$ 13,939.00	\$13,939.00
1	ZZXX1158	Accessible Whirl		\$ 17,315.00	\$17,315.00
1	ZZXX1138	ZoomTrax w/ Accessible Seat		\$ 14,725.00	\$14,725.00
1	ZZXX0818	8' Single Post Swing		\$ 1,738.00	\$1,738.00
1	ZZXX0819	8' Single Post Swing (add-a-bay)		\$ 1,195.00	\$1,195.00
1	ZZXX0892	Accessible Swing Seat		\$ 1,631.00	\$1,631.00
3	ZZXX0260	Belt Swing Seat		\$ 187.00	\$561.00
		<u>Site Equipment</u>			
1	ZZPSP005	14' x 14' Single Post Shade (Post Mount)		\$ 5,336.00	\$5,336.00
3	R20C4872	Swing and Slide Wear Mat		\$ 205.00	\$615.00
		<u>Discounting</u>			
		SourceWell Discount (11%)			-\$19,720.14
		<i>discount applied to non-sale items</i>			
		<u>Installation</u>			
		Playground Installation (Discounted)			\$41,078.84
				Subtotal:	\$288,762.33
				Freight:	\$10,882.32
				8.775% Sales Tax:	
				Total:	\$299,644.65

NOTE: Any Insurance requirements above \$1,000,000 General Liability will be subject to a surcharge

NOTE: Terms and Conditions of The State of Minnesota Purchasing Contract May Apply.

NOTE: UNLESS OTHERWISE NOTED, prices shown are material only. They DO NOT include: assembly, installation, border, safety surfacing, drain tile, geotextile fabric, removal of existing equipment, site preparation, excavation or site restoration, unloading of equipment, disposal of packaging material, storage of equipment, additional insurance and bonding would be extra, unless otherwise stated above. If playground equipment or materials are stored off site, customer is responsible for transporting equipment to job site.

Prices firm for 30 days, subject to review thereafter. Our terms are net 30. A finance charge of 1.5% will be imposed on the outstanding balance unpaid for more than 30 days after the shipment of materials. Equipment shall be invoiced separately from other services and shall be payable in advance of those services and project completion. Retainage not accepted. Once customer has signed quotation, your order cannot be changed or canceled. Please allow 3 to 4 weeks for delivery after receipt of order. Standard manufacturing design, specification, and construction apply unless noted otherwise. Customer is responsible for the identification of all underground utilities. Area must be accessible to Bobcat and other equipment necessary for installation or additional fees will be charged. Freight quote is based on customer unloading equipment and checking in all equipment for any missing parts. If product is refused by customer upon delivery for any reason (unless damaged), without prior authorization from Midwest Playscapes, Inc., the customer agrees to pay 20% restocking fee plus freight charges. Price does not include prevailing wages, unless otherwise noted. If we can be of Other Assistance, please feel free to contact us.

Name: _____
 Signed: _____
 Date: _____

Surfacing Type	Color/Blend	Black PIP Mix	Area
Engineered Wood Fiber	Natural	N/A	5,275 Sq.Ft.
Poured In Place	Blue	50/50	3,315 Sq.Ft.

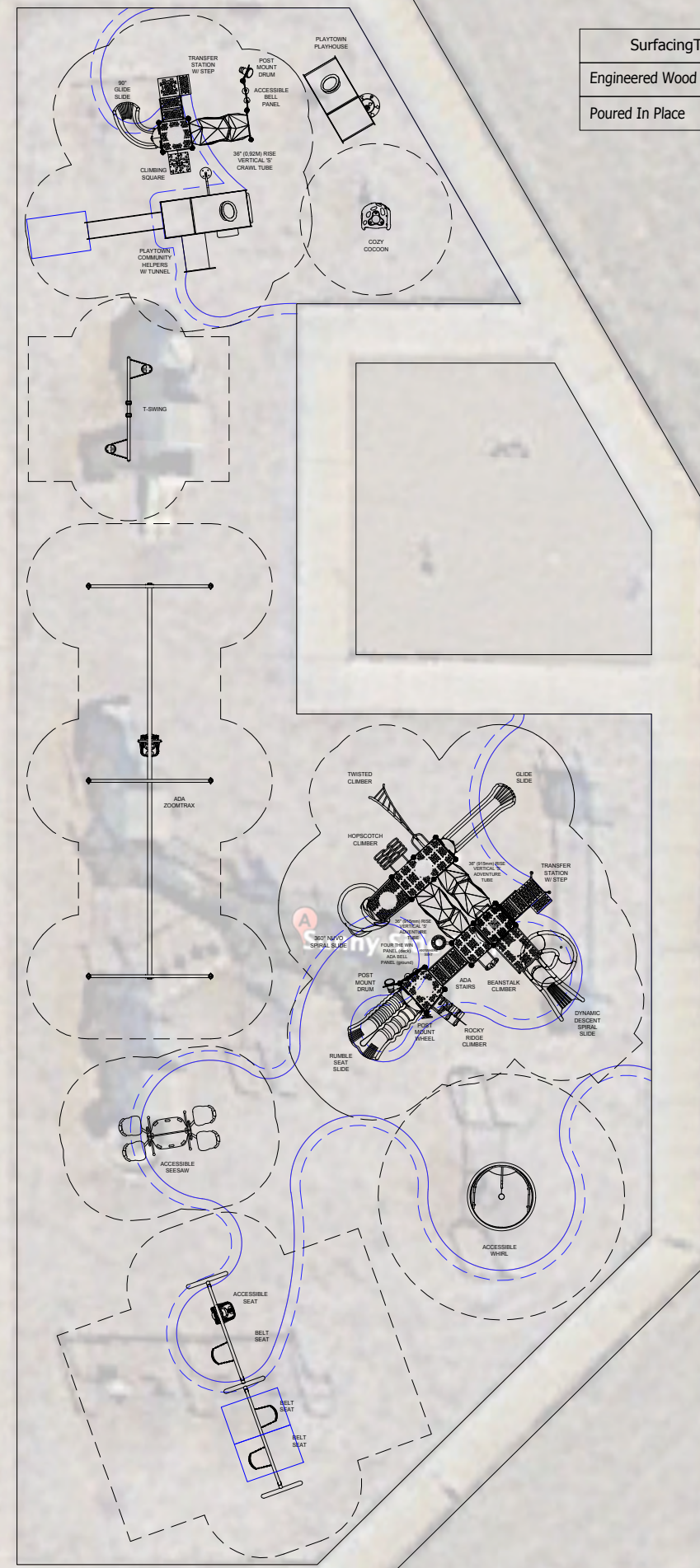

TOTAL AREA:
7,390 Sq.Ft.

PERIMETER:
450 Ft.

FALL HEIGHT:
8 Ft.

AGE GROUP:
2-5 & 5-12

DESIGN OPTION
01

NORTH



2-5/5-12

ADA SCHEDULE
Total Elevated Play Activities: 5 / 13
Total Ground-Level Play Activities: 8 / 11

	Accessible Elevated Activities	Accessible Ground-Level Activities	Accessible Ground-Level Play Types
Required	3 / 7	2 / 4	2 / 3
Provided	5 / 12	8 / 11	7 / 8

✓ ASTM F1487-11

✓ CPSC #325



PROJECT NO:
SP_20251121_01_01

SCALE:
1/16" = 1'-0"

DRAWN BY:
Tim Kelly

Paper Size

DATE:
11-21-25

B

*PLAYGROUND SUPERVISION REQUIRED

SUNNYSIDE PARK

ROGERS, MN

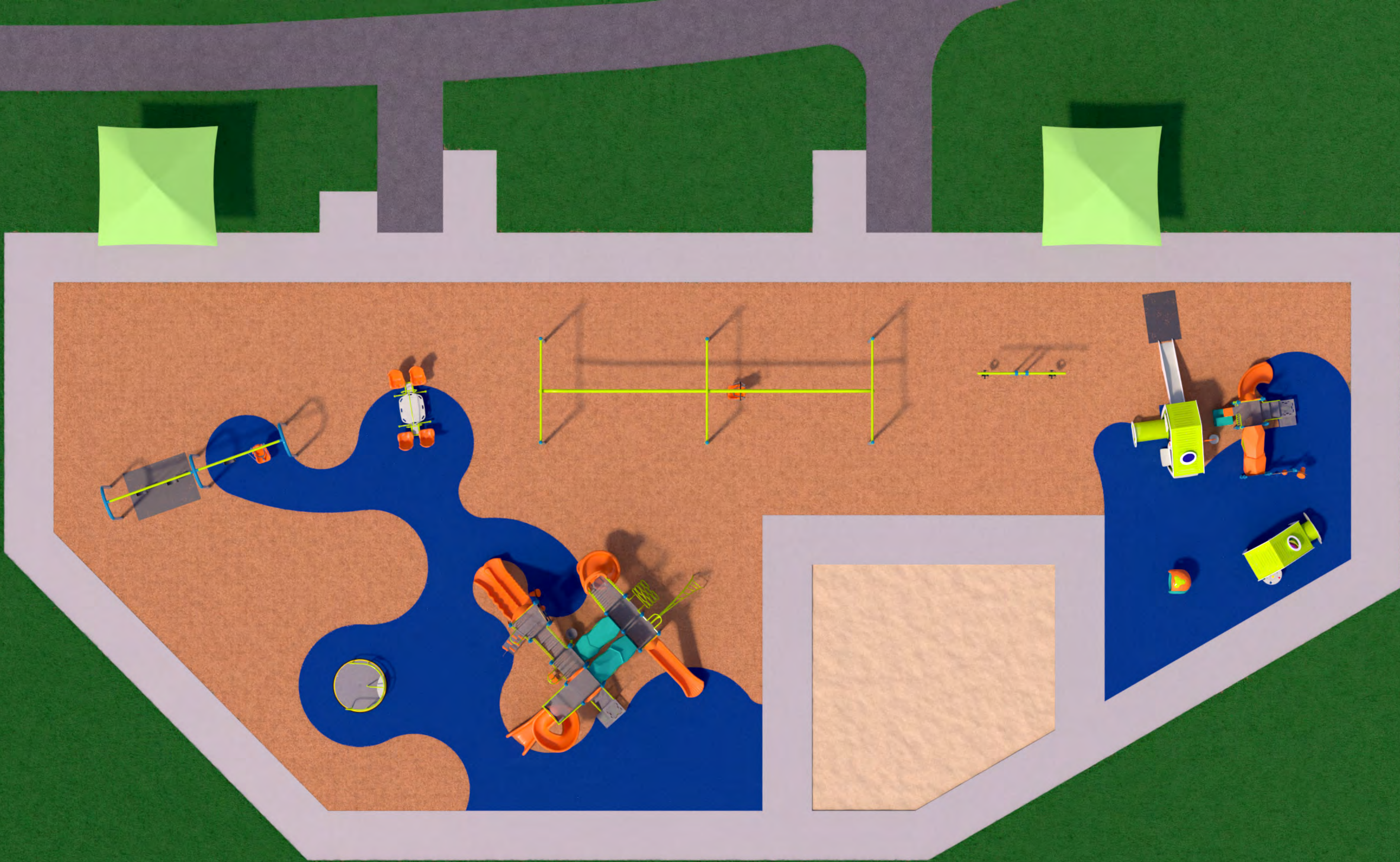

Sunnyside Park - Option 1



Sunnyside Park - Option 1



Sunnyside Park - Option 1



Sunnyside Park - Option 1



Sunnyside Park - Option 1



Sunnyside Park - Option 1



Sunnyside Park - Option 1

City of Rogers, MN

SUNNYSIDE PARK

MIDWEST PLAYSCAPES | PLAYGROUND REPLACEMENT

PROPOSAL - OPTION 2



PROPOSAL BY:



Tim Solomonson | PLA(MN) | CPSI
Project Manager | Architectural Liaison

PREPARED FOR:



TOLL FREE: 1-800-747-1452
Info@MidwestPlayscapes.com
8632 Eagle Creek Circle
Savage, MN 55378



TO: Mike Bauer | Parks and Recreation Director

DATE: Dec 8, 2025

Dear Mr. Bauer,

We are pleased to present three playground proposal options, each with unique themes, materials, and experiences, for Sunnyside Park in Rogers, MN. Our proposals will provide a turn-key playground installation for children ages 2-12 with an emphasis on inclusive and accessible ground-level and elevated play features supported by resilient rubber safety surfacing, shade, and a cooling focused misting water feature.

Each proposal option can be selected as-is, but our recommendation for a project of this scale and importance would be to work closely with the Parks and Recreation Commission and key city staff, if awarded, to develop a fully tailored playground solution that meets the needs of residents and operations and maintenance considers of the City while remaining under budget. We believe in a collaborative design approach on our projects and our team of Landscape Architects and designers understand the significance of this investment for the City. We want to ensure the final design creates the best possible outcomes for the City's residents and would welcome feedback and modifications to the design if desired.

All of our designs include:

- A 2-5 playground with swings, rockers, spinners, climbers and inclusive ground level and elevated features
- A 5-12 playground with swings, zipline, rockers, spinners, climbers and inclusive ground level and elevated features
- Shaded care giver seating
- A rubber safety surface system that links to key feature entry, exit, and wear points, ensuring maximum access, safety, and inclusivity while working as an extension of the play environment.
- All of the features meet all relevant ASTM and CPSC standards.

We take a lot of pride in delivering projects at the contracted price and will never request additional money for cost overruns should they occur. Longterm project outcomes and relationships are our priority. Our mission at Midwest Playscapes is to provide exciting, safe, and comfortable play environments for children of all ages and abilities.

We will be the sole point of contact for warranty and service requests should it be required and have dedicated warranty and service team to ensure the project is maintained to the highest standard throughout the life of the project and take a lot of pride in the longevity of our projects.

Thank you for your time and consideration.

With Gratitude,

A handwritten signature in black ink, appearing to read 'Tim Solomonson', written over a white background.

Tim Solomonson | PLA(MN) | CPSI | Project Manager

TOLL FREE: 1-800-747-1452
 Info@MidwestPlayscapes.com
 8632 Eagle Creek Circle
 Savage, MN 55378



QUOTATION - OPTION 2

Project:	Sunnyside Park Playground Replaceme	Sourcewell Info:	Phone:	763-428-0974
Contact:	Mike Bauer	Playworld Systems: #010521-LTS-8	Fax:	
Ship To:	22184 138th Ave N, Rogers, MN 55374		Bill To:	
Email:	mbauer@rogersmn.gov	Customer Name / Contract #:		
Shipping Contact:	tims@midwestplayscapes.com		Date:	12/8/25

Qty	Design / Item	Description	Inclusive	Unit Price	Total
		<u>Border, Surfacing, and Site Work</u>			
1	NOT IN CONTRACT	Removals and Container Prep (By Owner)			
100	TON	Drainage Aggregate		\$ 45.00	\$4,500.00
200	LF	Drain tile		\$ 1.50	\$300.00
255.72	CY	Engineered Wood Fiber		\$ 25.00	\$6,393.00
2307	SF	Poured-in-place Rubber Safety Surface		\$ 17.75	\$40,949.25
2307	SF	Poured-in-place Aggregate Base		\$ 4.60	\$10,612.20
		<u>2-5 Play Equipment</u>			
1	ACT-1303	Bambino Funburg		\$ 44,000.00	\$44,000.00
1	ZZXX0818	8' Single Post Swing		\$ 1,738.00	\$1,738.00
1	ZZXX0819	8' Single Post Swing (add-a-bay)		\$ 1,195.00	\$1,195.00
1	ZZXX0892	Accessible Swing Seat		\$ 1,631.00	\$1,631.00
1	ZZXX0265	Tot Swing Seat		\$ 326.00	\$326.00
2	ZZXX0260	Belt Swing Seat		\$ 187.00	\$374.00
		<u>5-12 Play Equipment</u>			
1	350-2204	Adventure Mountain (Age 5-12)		\$ 66,500.00	\$66,500.00
1	TZ-2310	Ropescapes - Tianzi		\$ 39,500.00	\$39,500.00
1	ZZXX0084	Unity Ring		\$ 10,261.00	\$10,261.00
1	ZZXX0598	Quattro Seesaw		\$ 9,734.00	\$9,734.00
1	ZZXX1145	LiveWire Zip Line		\$ 26,117.00	\$26,117.00
		<u>Site Equipment</u>			
1	ZZPSP005	14' x 14' Single Post Shade (Post Mount)		\$ 5,336.00	\$5,336.00
2	R20C4872	Swing and Slide Wear Mat		\$ 205.00	\$410.00
		<u>Discounting</u>			
		SourceWell Discount (11%)			-\$22,738.32
		<i>discount applied to non-sale items</i>			
		<u>Installation</u>			
		Playground Installation (Discounted)			\$42,375.96
				Subtotal:	\$289,514.09
				Freight:	\$10,268.48
	Tax Exempt #	* Please provide certificate		8.775% Sales Tax:	
				Total:	\$299,782.57

NOTE: Any Insurance requirements above \$1,000,000 General Liability will be subject to a surcharge

NOTE: Terms and Conditions of The State of Minnesota Purchasing Contract May Apply.

NOTE: UNLESS OTHERWISE NOTED, prices shown are material only. They DO NOT include: assembly, installation, border, safety surfacing, drain tile, geotextile fabric, removal of existing equipment, site preparation, excavation or site restoration, unloading of equipment, disposal of packaging material, storage of equipment, additional insurance and bonding would be extra, unless otherwise stated above. If playground equipment or materials are stored off site, customer is responsible for transporting equipment to job site.

Prices firm for 30 days, subject to review thereafter. Our terms are net 30. A finance charge of 1.5% will be imposed on the outstanding balance unpaid for more than 30 days after the shipment of materials. Equipment shall be invoiced separately from other services and shall be payable in advance of those services and project completion. Retainage not accepted. Once customer has signed quotation, your order cannot be changed or canceled. Please allow 3 to 4 weeks for delivery after receipt of order. Standard manufacturing design, specification, and construction apply unless noted otherwise. Customer is responsible for the identification of all underground utilities. Area must be accessible to Bobcat and other equipment necessary for installation or additional fees will be charged. Freight quote is based on customer unloading equipment and checking in all equipment for any missing parts. If product is refused by customer upon delivery for any reason (unless damaged), without prior authorization from Midwest Playscapes, Inc., the customer agrees to pay 20% restocking fee plus freight charges. Price does not include prevailing wages, unless otherwise noted. If we can be of Other Assistance, please feel free to contact us.

Name: _____
 Signed: _____
 Date: _____

Surfacing Type	Color/Blend	Black PIP Mix	Area
Engineered Wood Fiber	Natural	N/A	6,710 Sq.Ft.
Poured In Place	Blue	50/50	2,330 Sq.Ft.

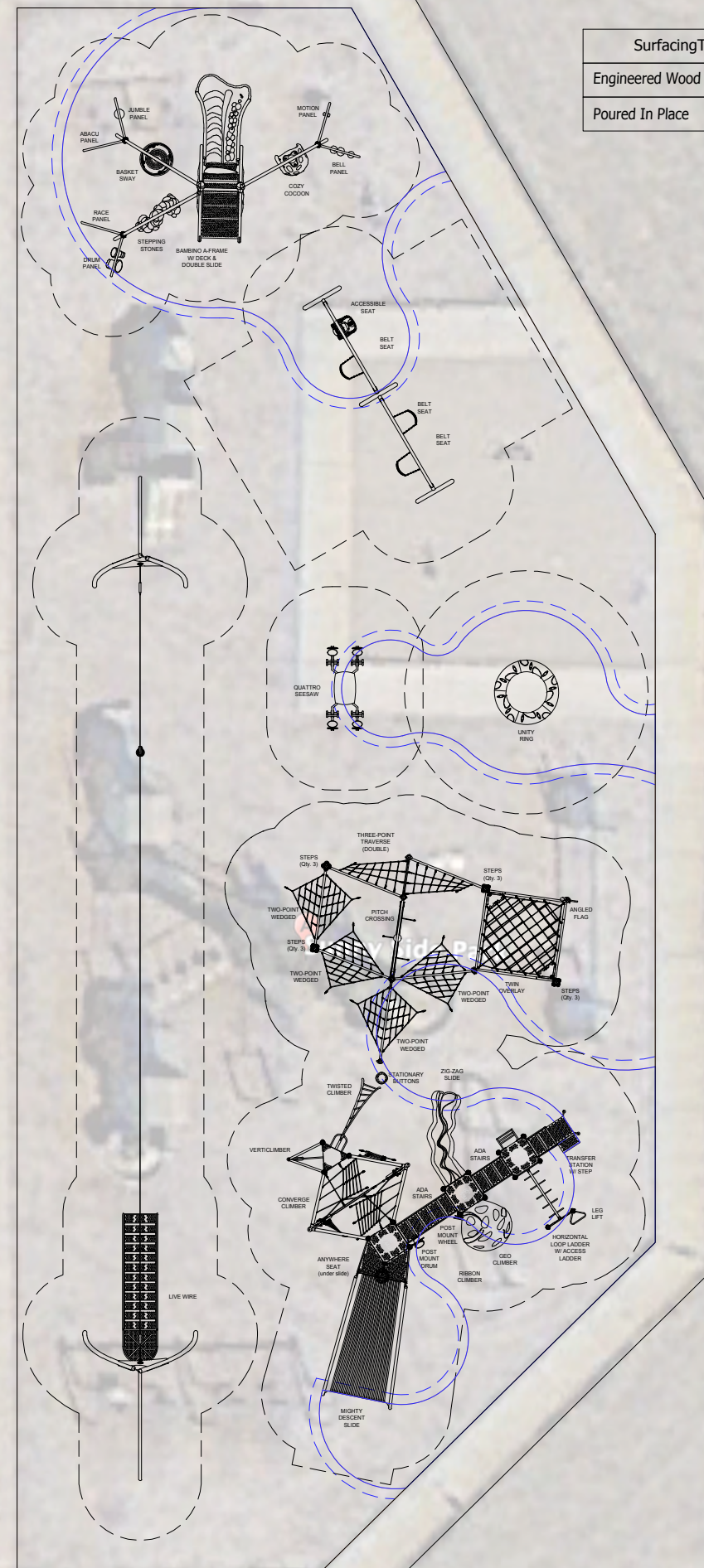

TOTAL AREA:
8,730 Sq.Ft.

PERIMETER:
402 Ft.

FALL HEIGHT:
8 Ft.

AGE GROUP:
2-5 & 5-12

DESIGN OPTION
01

NORTH



2-5/5-12

ADA SCHEDULE	Total Elevated Play Activities: 0 / 8		
	Total Ground-Level Play Activities: 14 / 15		
	Accessible Elevated Activities	Accessible Ground-Level Activities	Accessible Ground-Level Play Types
Required	0 / 4	0 / 3	0 / 3
Provided	0 / 5	14 / 15	11 / 12

- ✓ ASTM F1487-11
- ✓ CPSC #325



PROJECT NO:
SP_20251121_01_01

SCALE:
1/16" = 1'-0"

DRAWN BY:
Tim Kelly

Paper Size

DATE:
11-21-25

B

*PLAYGROUND SUPERVISION REQUIRED

SUNNYSIDE PARK
ROGERS, MN

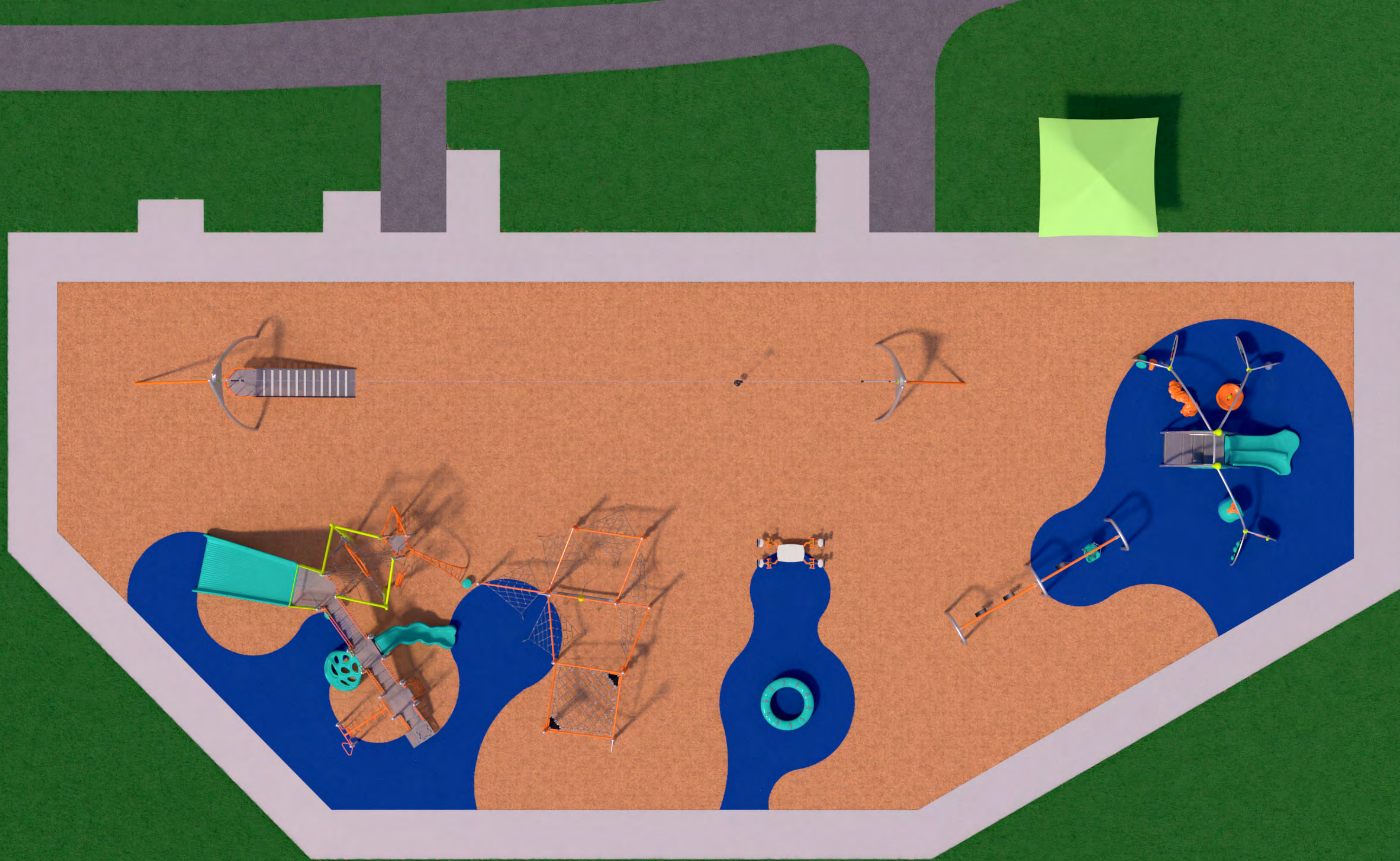





Sunnyside Park - Option 2



Sunnyside Park - Option 2







Sunnyside Park - Option 2

Sunnyside Park

Design Number: SP_20251121_02_01 - Bill Of Material

Ref. No.	Part No.	Description	Quantity
		Slides	
1	ZZAC0030	BAMBINO A-FRAME	1
		Climbers	
2	ZZAC0032	BAMBINO ARCH - STEPPING STONES	1
		Balance	
3	ZZAC0033	BAMBINO ARCH - COCOON	1
4	ZZAC0034	BAMBINO ARCH - BASKET SWAY	1
		Activity Panels	
5	ZZAC0035	OUTRIGGERS FOR PANELS	3
6	ZZAC0037	BAMBINO BELL PANEL	1
7	ZZAC0038	BAMBINO DRUM PANEL	1
8	ZZAC0040	BAMBINO CAR RACE PANEL	1
9	ZZAC0041	BAMBINO COUNTING PANEL	1
10	ZZAC0042	BAMBINO MOVE-IT PANEL	1
11	ZZAC0043	BAMBINO JUMBLE PANEL	1
		Posts	
12	ZZCH0018	3.5in OD x 124in STEEL POST W/RIVETED CAP	2
13	ZZCH0028	3.5in OD x 136in STEEL POST W/ RIVETED CAP	4
14	ZZCH0038	3.5in OD x 148in STEEL POST W/ RIVETED CAP	4
15	ZZCH0068	3.5in OD x 184in STEEL POST POST W/RIVETED CAP	2
16	ZZCH0258	3.5in OD x 224in STEEL POST W/CAP	4
		Decks & Kick Plates	
17	ZZCH0616	SQUARE COATED DECK ASSEMBLY	3
18	ZZCH0617	TRIANGULAR COATED DECK ASSEMBLY	1
		Posts	
19	ZZCH0891	FILLER POST- MIGHTY DESCENT SLIDE 96in DECK (CH)	1
		ADA Items	
20	ZZCH2007	TRANSFER STATION w/TALL GUARDRAILS (36in DECK)	1
		Slides	
21	ZZCH3236	ZIGZAG SLIDE (60in DECK)	1
		Activity Panels	
22	ZZCH4290	POST MOUNTED STEERING WHEEL	1
23	ZZCH4578	ANYWHERE SEAT	1
		Audible Activities	
24	ZZCH4649	POST MOUNT DRUM	1
		Slides	
25	ZZCH4696	MIGHTY DESCENT	1
		Climbers	
26	ZZCH4704	VERTICLIMBER 72in	1
27	ZZCH4707	CONVERGE	1
		Overhead Events	
28	ZZCH5770	LEG LIFT	1
29	ZZCH5780	6ft HORIZONTAL LOOP LADDER	1



Sunnyside Park

Design Number: SP_20251121_02_01 - Bill Of Material

Ref. No.	Part No.	Description	Quantity
30	ZZCH5970	OVERHEAD EVENT ACCESS LADDER (36in DECK) Climbers	1
31	ZZCH6757	5ft GEO CLIMBER	1
32	ZZCH7160	6ft TWISTED CLIMBER	1
33	ZZCH8289	RIBBON CLIMBER (36in DECK) Stairs and Ladders	1
34	ZZCH9170	24in ACCESS STEPPED PLATFORM (DECK TO DECK)	1
35	ZZCH9177	36in ACCESS STEPPED PLATFORM (DECK TO DECK) Posts	1
36	ZZPM0036GZ	5in OD X 144in STEEL POST (GROUND ZERO)	7
37	ZZPM0056GZ	5in OD X 168in STEEL POST W/ CAP (GROUND ZERO)	1
38	ZZPM0236GZ	5in OD x 164in SWAGED STEEL GROUND ZERO POST Ground Zer0 Climbers	2
39	ZZPM5001	TIANZI TWIN OVERLAY	1
40	ZZPM5003	TIANZI PITCH CROSSING	1
41	ZZPM5004	TIANZI TWO-POINT WEDGE	4
42	ZZPM5007	TIANZI THREE-POINT TRAVERSE - DOUBLE	1
43	ZZPM5008	STEP AROUND Roofs & Arches	12
44	ZZPM5009	ANGLED FLAG ADA Items	2
45	ZZUN2019	APPROACH STEP FOR TRANSFER STATION Balance	1
46	ZZUN7140	STATIONARY BUTTONS (12in)	1



Sunnyside Park

Design Number: SP_20251121_02_01 - Compliance and Technical Data

Reference Document: ASTM F1487

Ref. No.	Part No.	Qty.	Description	Unit ASTM Status	Total Weight (lbs)	Pre-Consumer Recycled Content (lbs)	Post-Consumer Content (lbs)	CO2e Footprint (kgs)	Users	Install Hours	Concrete (Yds3)	Active Play Events
1	ZZAC0030	1	BAMBINO A-FRAME	Certified	1,061.23			3,731	6	10.50	0.63	3
2	ZZAC0032	1	BAMBINO ARCH - STEPPING STONES	Certified	138.67			772	2	3.50	0.25	1
3	ZZAC0033	1	BAMBINO ARCH - COCOON	Certified	207.17			1,309	3	3.00	0.26	1
4	ZZAC0034	1	BAMBINO ARCH - BASKET SWAY	Certified	154.19			878	0	2.00	0.26	0
5	ZZAC0035	3	OUTRIGGERS FOR PANELS	Certified	249.12			557	0	3.75	0.18	0
6	ZZAC0037	1	BAMBINO BELL PANEL	Certified	35.81			346	2	0.50	0.00	1
7	ZZAC0038	1	BAMBINO DRUM PANEL	Certified	36.35			386	2	0.50	0.00	1
8	ZZAC0040	1	BAMBINO CAR RACE PANEL	Certified	28.03			338	2	0.50	0.00	1
9	ZZAC0041	1	BAMBINO COUNTING PANEL	Certified	33.31			439	2	0.50	0.00	1
10	ZZAC0042	1	BAMBINO MOVE-IT PANEL	Certified	37.72			458	2	0.50	0.00	1
11	ZZAC0043	1	BAMBINO JUMBLE PANEL	Certified	41.53			684	2	0.50	0.00	1
12	ZZCH0018	2	3.5in OD x 124in STEEL POST W/RIVETED CAP	Certified	77.82			108	0	2.00	0.25	0
13	ZZCH0028	4	3.5in OD x 136in STEEL POST W/ RIVETED CAP	Certified	174.04			234	0	4.00	0.50	0
14	ZZCH0038	4	3.5in OD x 148in STEEL POST W/ RIVETED CAP	Certified	188.44			253	0	4.00	0.50	0
15	ZZCH0068	2	3.5in OD x 184in STEEL POST POST W/RIVETED CAP	Certified	114.22			155	0	2.00	0.25	0
16	ZZCH0258	4	3.5in OD x 224in STEEL POST W/CAP	Certified	262.04			374	0	4.00	0.52	0
17	ZZCH0616	3	SQUARE COATED DECK ASSEMBLY	Certified	164.58			521	9	3.00	0.00	0
18	ZZCH0617	1	TRIANGULAR COATED DECK ASSEMBLY	Certified	29.90			120	2	1.00	0.00	0
19	ZZCH0891	1	FILLER POST- MIGHTY DESCENT SLIDE 96in DECK (CH)	Certified	44.50			13	0	0.75	0.13	0
20	ZZCH2007	1	TRANSFER STATION w/TALL GUARDRAILS (36in DECK)	Certified	144.90			310	2	2.00	0.09	0
21	ZZCH3236	1	ZIGZAG SLIDE (60in DECK)	Certified	153.73			679	2	2.00	0.03	1
22	ZZCH4290	1	POST MOUNTED STEERING WHEEL	Certified	7.83			44	1	0.25	0.00	1
23	ZZCH4578	1	ANYWHERE SEAT	Certified	31.10			90	1	0.25	0.00	1



Sunnyside Park

Design Number: SP_20251121_02_01 - Compliance and Technical Data

Reference Document: ASTM F1487

Ref. No.	Part No.	Qty.	Description	Unit ASTM Status	Total Weight (lbs)	Pre-Consumer Recycled Content (lbs)	Post-Consumer Content (lbs)	CO2e Footprint (kgs)	Users	Install Hours	Concrete (Yds3)	Active Play Events
24	ZZCH4649	1	POST MOUNT DRUM	Certified	12.78			167	1	0.50	0.00	1
25	ZZCH4696	1	MIGHTY DESCENT	Certified	748.50			1,120	8	7.00	0.18	1
26	ZZCH4704	1	VERTICLIMBER 72in	Certified	126.40			91	2	1.50	0.13	1
27	ZZCH4707	1	CONVERGE	Certified	714.90			1,443	10	9.00	0.38	1
28	ZZCH5770	1	LEG LIFT	Certified	6.76			30	1	0.50	0.00	1
29	ZZCH5780	1	6ft HORIZONTAL LOOP LADDER	Certified	55.72			124	4	1.00	0.00	1
30	ZZCH5970	1	OVERHEAD EVENT ACCESS LADDER (36in DECK)	Certified	25.12			71	1	1.50	0.06	0
31	ZZCH6757	1	5ft GEO CLIMBER	Certified	120.46			535	2	2.00	0.09	1
32	ZZCH7160	1	6ft TWISTED CLIMBER	Certified	117.65			241	2	2.00	0.60	1
33	ZZCH8289	1	RIBBON CLIMBER (36in DECK)	Certified	35.02			101	2	1.50	0.06	1
34	ZZCH9170	1	24in ACCESS STEPPED PLATFORM (DECK TO DECK)	Certified	135.24			296	1	2.00	0.00	0
35	ZZCH9177	1	36in ACCESS STEPPED PLATFORM (DECK TO DECK)	Certified	217.24			550	2	1.50	0.00	0
36	ZZPM0036GZ	7	5in OD X 144in STEEL POST (GROUND ZERO)	Certified	562.87			822	0	10.50	1.26	0
37	ZZPM0056GZ	1	5in OD X 168in STEEL POST W/ CAP (GROUND ZERO)	Certified	97.01			136	0	1.00	0.18	0
38	ZZPM0236GZ	2	5in OD x 164in SWAGED STEEL GROUND ZERO POST	Certified	189.22			253	0	1.00	0.36	0
39	ZZPM5001	1	TIANZI TWIN OVERLAY	Certified	284.60			3,360	8	2.00	0.00	1
40	ZZPM5003	1	TIANZI PITCH CROSSING	Certified	165.30			771	2	4.00	0.15	1
41	ZZPM5004	4	TIANZI TWO-POINT WEDGE	Certified	402.40			2,862	16	10.00	0.40	4
42	ZZPM5007	1	TIANZI THREE-POINT TRAVERSE - DOUBLE	Certified	172.80			1,066	6	3.00	0.10	1
43	ZZPM5008	12	STEP AROUND	Certified	81.60			1,286	12	6.00	0.00	12
44	ZZPM5009	2	ANGLED FLAG	Certified	76.00			396	0	1.00	0.00	0
45	ZZPSP005	1	SINGLE POST PYRAMID 14X14X8- IN-GROUND POST	N/A	750.00			715	0	0.00	0.00	0
46	ZZUN2019	1	APPROACH STEP FOR TRANSFER STATION	Certified	35.83			72	1	1.00	0.04	0



Sunnyside Park

Design Number: SP_20251121_02_01 - Compliance and Technical Data

Reference Document: ASTM F1487







Ref. No.	Part No.	Qty.	Description	Unit ASTM Status	Total Weight (lbs)	Pre-Consumer Recycled Content (lbs)	Post-Consumer Content (lbs)	CO2e Footprint (kgs)	Users	Install Hours	Concrete (Yds3)	Active Play Events
47	ZZUN7140	1	STATIONARY BUTTONS (12in)	Certified	27.12			90	1	0.75	0.13	1
48	ZZXX0084	1	UNITY RING	Certified	457.20			3,378	9	2.50	0.52	1
49	ZZXX0260	3	BELT SEAT W/SILVER SHIELD CHAIN FOR 8ft TOP RAIL	Certified	26.40			162	3	0.75	0.00	3
50	ZZXX0598	1	QUATTRO SEE-SAW (w/ SEAT BACKS)	Certified	482.67			1,510	6	5.00	0.24	1
51	ZZXX0892	1	ACCESSIBLE SWING SEAT- 8ft TOP RAIL	N/A	53.80			314	0	0.50	0.00	0
52	ZZXX0931	1	5in OD 2-UNIT STEEL ARCH SWING- 8ft TOP RAIL	Certified	417.00			84	0	3.00	0.48	0
53	ZZXX0933	1	5in OD STEEL ARCH SWING 2-UNIT ADD-A-BAY	Certified	249.30			84	0	2.00	0.24	0
54	ZZXX1145	1	LIVE WIRE	Certified	1,702.05			4,458	3	32.00	1.70	1
Totals:					11,965.19	1,973	3,994	39,386	143	167.00	11.15	49
					0 Kg	0 Kg	0 Kg	0 Metric Tons				0 m3



Sunnyside Park

Design Number: SP_20251121_02_01 - Compliance and Technical Data

Reference Document: ASTM F1487

Ref. No.	Part No.	Qty.	Description	Unit ASTM Status	Total Weight (lbs)	Pre-Consumer Recycled Content (lbs)	Post-Consumer Content	CO2e Footprint (kgs)	Users	Install Hours	Concrete (Yds3)	Active Play Events
	ASTM F1487		The lay-out for this custom playscape, design number SP_20251121_02_01, has been configured to meet the requirements of the ASTM F1487 standard. In addition, each of the above components listed as "Certified" have been tested and are IPEMA certified. Components listed as "Not Applicable" do not fall within the scope of the ASTM F1487 standard and have not been tested. IPEMA certification can be verified on the IPEMA website, www.ipema.org. In the interest of playground safety, IPEMA provides a Third Party Certification Service which validates compliance.									
	2010 ADA Standards for Accessible Design		The lay-out was also designed to meet the 2010 Standards published 15-Sep-2010, by the Department of Justice when installed over a properly maintained surfacing material that is in compliance with ASTM F1951 "Accessibility of Surface Systems Under and Around Playground Equipment" as well as ASTM F1292, "Impact Attenuation of Surfacing Materials Within the Use Zone of Playground Equipment", appropriate for the fall height of the structure.									
	Installation Times		Installation times are based on one experienced installer. A crew of three experienced individuals can perform the installation within the given time, each member working 1/3 of the given hours. [Eg. Installation Time = 30 hours. For a crew of three, each member will work 10 hours on the installation for a total of 30 hours on the project.]									
	Carbon Footprint		The CO2e (carbon footprint given in Kilograms and Metric Tons) listed above is a measure of the environmental impact this play structure represents from harvesting raw materials to the time it leaves our shipping dock. Playworld Systems nurtures a total corporate culture that is focused on eliminating carbon producing processes and products, reducing our use of precious raw materials, reusing materials whenever possible and recycling materials at every opportunity. Playworld Systems elected to adopt the Publicly Available Specification; PAS 2050 as published by the British Standards Institute and sponsored by Defra and the Carbon Trust. The PAS 2050 has gained international acceptance as a specification that measures the greenhouse gas emissions in services and goods throughout their entire life cycle.									
	Pre-Consumer Recycle Content		A measurement, in pounds, that qualifies the amount of material that was captured as waste and diverted from landfill during an initial manufacturing process and is being redirected to a separate manufacturing process to become a different product. E.g. 100% of our Aluminum Tubing is made from captured waste material during the manufacturing process of extruded Aluminum products such as rods, flat bars and H-channels.									
	Post-Consumer Recycle Content		A measurement, in pounds, that qualifies the amount of material that was once another product that has completed its lifecycle and has been diverted from a landfill as a solid waste through recycling and is now being used in a Playworld Systems' product. E.g. **20% to 40% of the steel in our steel tubing and sheet steel have been diverted from landfills. Automobiles are scrapped and recyclable steel is purchased by the steel mill that produces our raw product. ** The amount of Post-Consumer recycled steel fluctuates daily based on the availability of the recycled steel.									





A PLAYCORP Company



Color Palette: Whimsy Way

- Uprights: White
- Accent: Blue
- Accent 2: Sky Blue
- 2-Color HDPE: Spring Green/White
- 2-Color 2: Orange/White
- HDPE: Orange
- Deck: Gray
- Roto Plastic: Periwinkle
- Tube: Sky Blue
- Cabling: Black
- Uni Plastic: Deep Granite
- Metal Roof: Orange
- Fabric: Navy Blue
- Coated Site: Gray
- PIP: 50-50 Bright Blue/Black

SUNNYSIDE PARK - OPT. 1
 Rogers, MN D12924L



Please Sign & Date the Final Top View:

While it is our intention to install your playground in a safe and timely manner, our success relies on your preparedness. Site preparation and grading to be performed by others and prior to installation. Slope within the play area(s) shall not exceed 1% to ensure a successful installation and a compliant playground. Drain tile systems other than within 4' of the perimeter along drain aggregate base material may require installing after the installation of the play equipment and must be coordinated with installation of safety surface materials. Failure to prepare site(s) to these expectations may result in additional charges if installer is required to re-mobilize. Please contact MN WI Playground if you have any questions.

Maximum depth of safety surface and drain aggregate base should not exceed an 18" depth and shall not be installed until play equipment has been installed.

EXISTING SITE FURNISHINGS

POURED-IN-PLACE SAFETY SURFACING
238 SF TOTAL

EXISTING SIDEWALK

- TUFFCLAD
6' BENCH w/BACK
IN-GROUND (PS)
28009
- 6' HYPERBOLIC UMBRELLA
10' x 10'
(HYU101008IG)
ORI433
- TUFFCLAD
6' BENCH w/BACK
IN-GROUND (PS)
28009

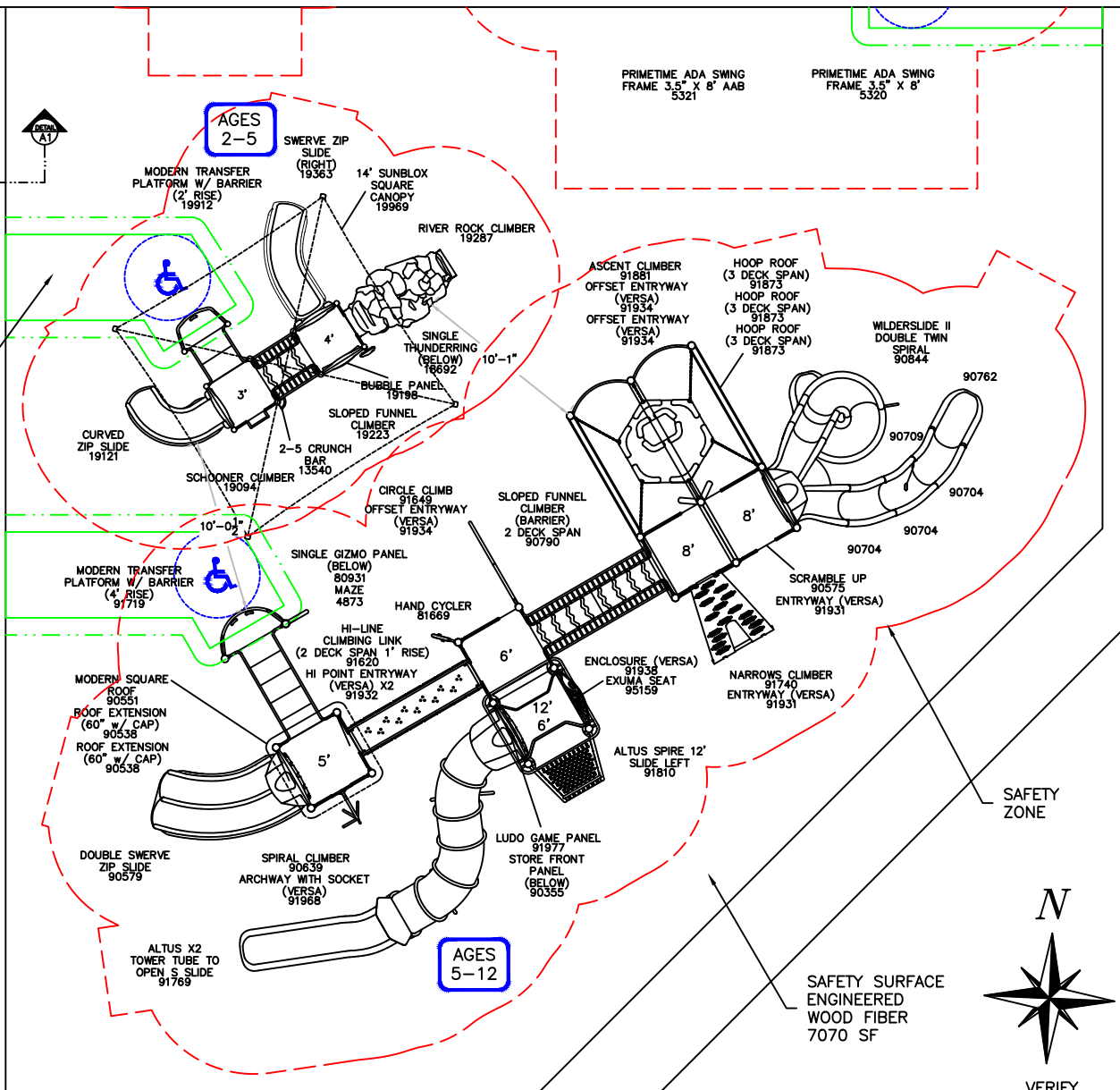
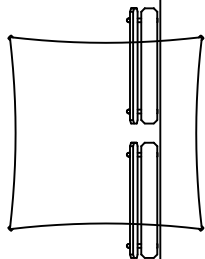

PRIMETIME ADA SWING
FRAME 3.5' X 8' AAB
5321

PRIMETIME ADA SWING
FRAME 3.5' X 8'
5320

AGES
2-5

AGES
5-12

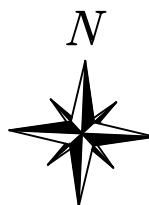

VERIFY LOCATION AND ORIENTATION

SAFETY SURFACE
ENGINEERED
WOOD FIBER
7070 SF

SCALE IN FEET



ADA REQUIREMENTS FOR STRUCTURE AGES 5-12 YEARS OLD AGES 2-5 YEARS OLD

TOTAL NUMBER OF ELEVATED PLAY COMPONENTS	IN PLAN 12	REQ'D. 6	IN PLAN 6	REQ'D. 3
TOTAL EVENTS ACCESSIBLE VIA TRANSFER	IN PLAN 11	REQ'D. 0	IN PLAN 6	REQ'D. 0
TOTAL ACCESSIBLE EVENTS VIA RAMP	IN PLAN 0	REQ'D. 4	IN PLAN 0	REQ'D. 2
TOTAL ACCESSIBLE GROUND LEVEL EVENTS	IN PLAN 12	REQ'D. 3	IN PLAN 4	REQ'D. 2
DIFFERENT TYPES OF GROUND LEVEL EVENTS	IN PLAN 7	REQ'D. 3	IN PLAN 3	REQ'D. 2

THIS PLAYGROUND MEETS ALL CURRENT ADA REQUIREMENTS & THE FINAL RULE ABOVE CHART/INFO IS APPLICABLE WHEN USING AN ACCESSIBLE SAFETY SURFACE

SCALE: 1" = 10'-0"



Sold & Distributed By:



P.O. Box 27328, Golden Valley, MN 55427
763-546-7787 1-800-622-5425
Fax 763-546-5050
E-Mail info@mwprecreation.com

Sunnyside Park - Option 1

Rogers, MN

12-2-25

DWG. D12924L

THIS PLAN REQUIRES A FINISHED GRADE RESOLUTION

While it is our intention to install your playground in a safe and timely manner, our success relies on your preparedness. Site preparation and grading to be performed by others and prior to installation. Slope within the play area(s) shall not exceed 1% to ensure a successful installation and a compliant playground. Drain tile systems other than within 4' of the perimeter along drain aggregate base material may require installing after the installation of the play equipment and must be coordinated with installation of safety surface materials. Failure to prepare site(s) to these expectations may result in additional charges if installer is required to re-mobilize. Please contact MN WI Playground if you have any questions.

Maximum depth of safety surface and drain aggregate base should not exceed an 18" depth and shall not be installed until play equipment has been installed.

- TUFFCLAD 6' BENCH w/BACK IN-GROUND (PS) 28009
- 8' HYPERBOLIC UMBRELLA 10' x 10' (HYU) (1008IG) QR433
- TUFFCLAD 6' BENCH w/BACK IN-GROUND (PS) 28009

EXISTING SIDEWALK

EXISTING SITE FURNISHINGS

SAFETY ZONE

Please Sign & Date the Final Top View:

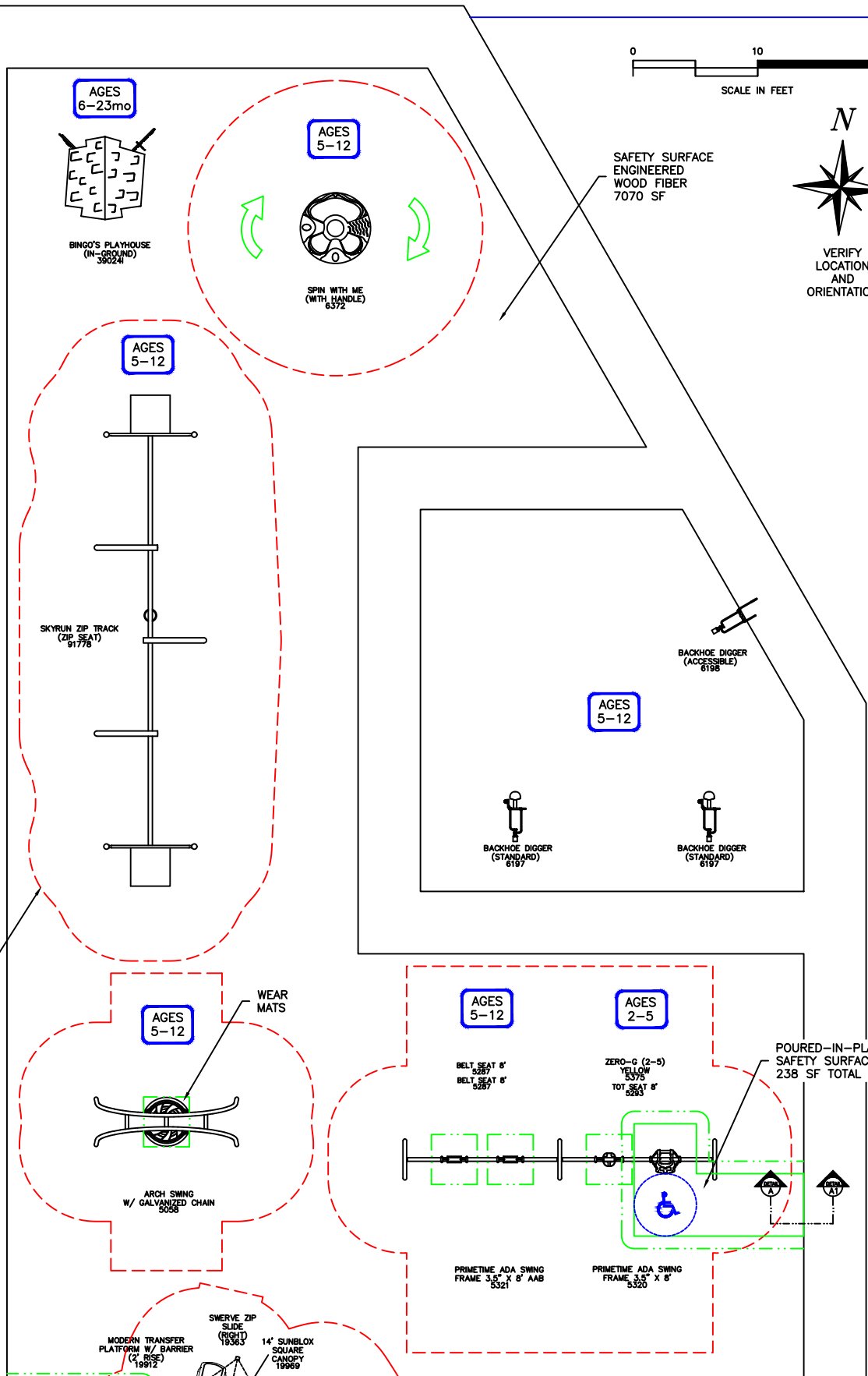
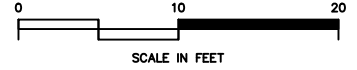

Mfg. By:

 Enriching Childhood Through Play.

Sold & Distributed By:

 P.O. Box 27328, Golden Valley, MN 55427
 763-546-7787 1-800-622-5425
 Fax 763-546-5050
 E-Mail info@mwprecreation.com

Sunnyside Park - Option 1
 Rogers, MN

12-2-25

DWG. D12924L

THIS PRINT IS THE PROPERTY OF MINNESOTA WISCONSIN PLAYGROUND INC. AND IS NOT TO BE USED, COPIED OR REPRODUCED WITHOUT THEIR EXPRESSED WRITTEN PERMISSION.

SCALE: 1" = 12'-0"

Please Sign & Date the Final Top View:

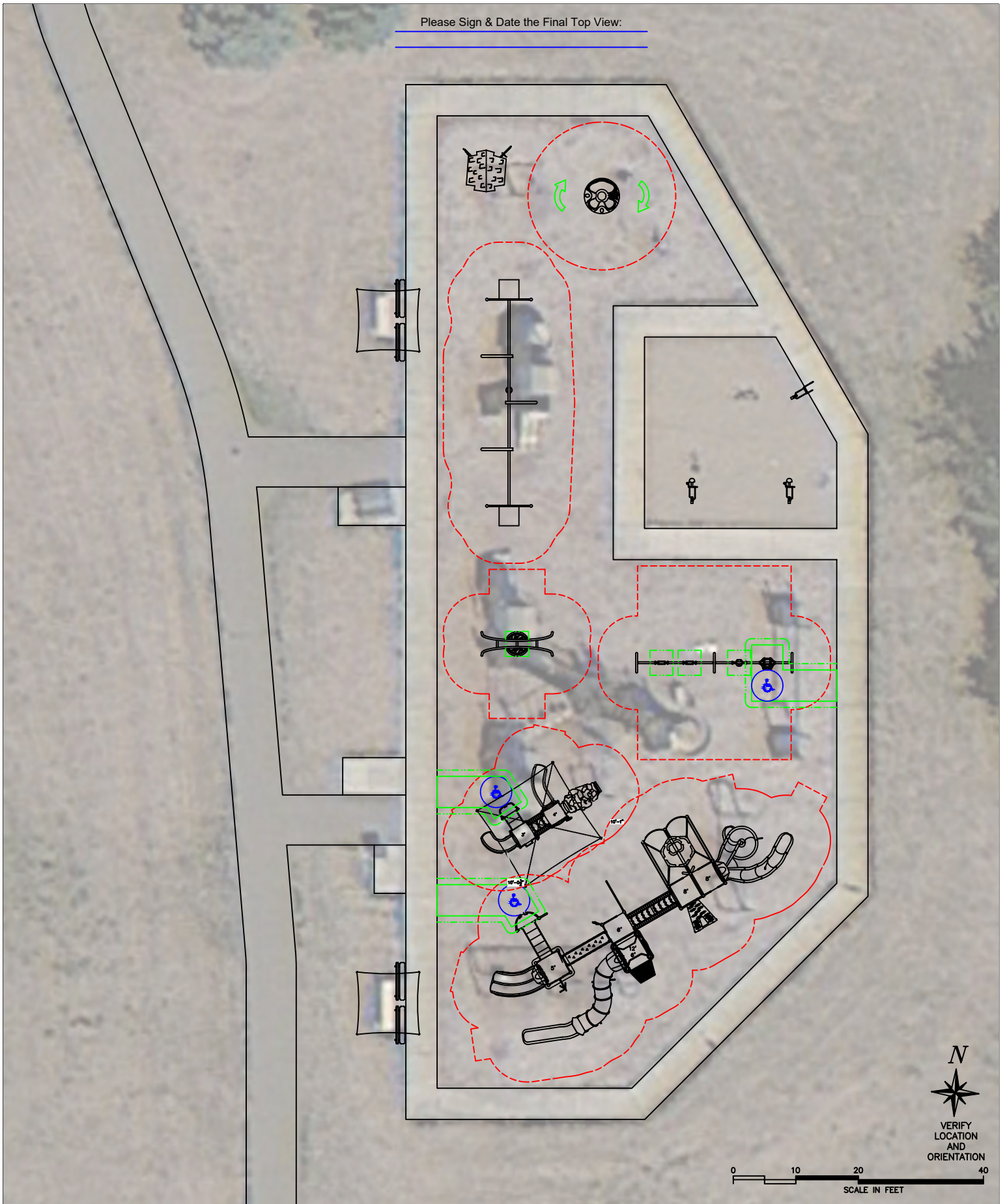

Mfg. By:
GameTime
A PLAYCORE COMPANY
Enriching Childhood Through Play.

Sold & Distributed By:
recreation
P.O. Box 27328, Golden Valley, MN 55427
763-546-7787 1-800-622-5425
Fax 763-546-5050
E-Mail info@mwprecreation.com

THIS PLAN REQUIRES A FINISHED GRADE RESOLUTION

Sunnyside Park - Option 1
Rogers, MN
12-2-25 DWG. D12924L

THIS PRINT IS THE PROPERTY OF MINNESOTA WISCONSIN PLAYGROUND INC. AND IS NOT TO BE USED, COPIED OR REPRODUCED WITHOUT THEIR EXPRESSED WRITTEN PERMISSION. SCALE: 1" = 20'-0"



SUNNYSIDE PARK - OPT. 1
Rogers, MN D12924L





SUNNYSIDE PARK - OPT. 1
Rogers, MN D12924L





SUNNYSIDE PARK - OPT. 1
Rogers, MN D12924L





SUNNYSIDE PARK - OPT. 1
Rogers, MN D12924L





SUNNYSIDE PARK - OPT. 1
Rogers, MN D12924L





SUNNYSIDE PARK - OPT. 1
Rogers, MN D12924L





SUNNYSIDE PARK - OPT. 1
Rogers, MN D12924L





SUNNYSIDE PARK - OPT. 1
Rogers, MN D12924L





SUNNYSIDE PARK - OPT. 1
Rogers, MN D12924L



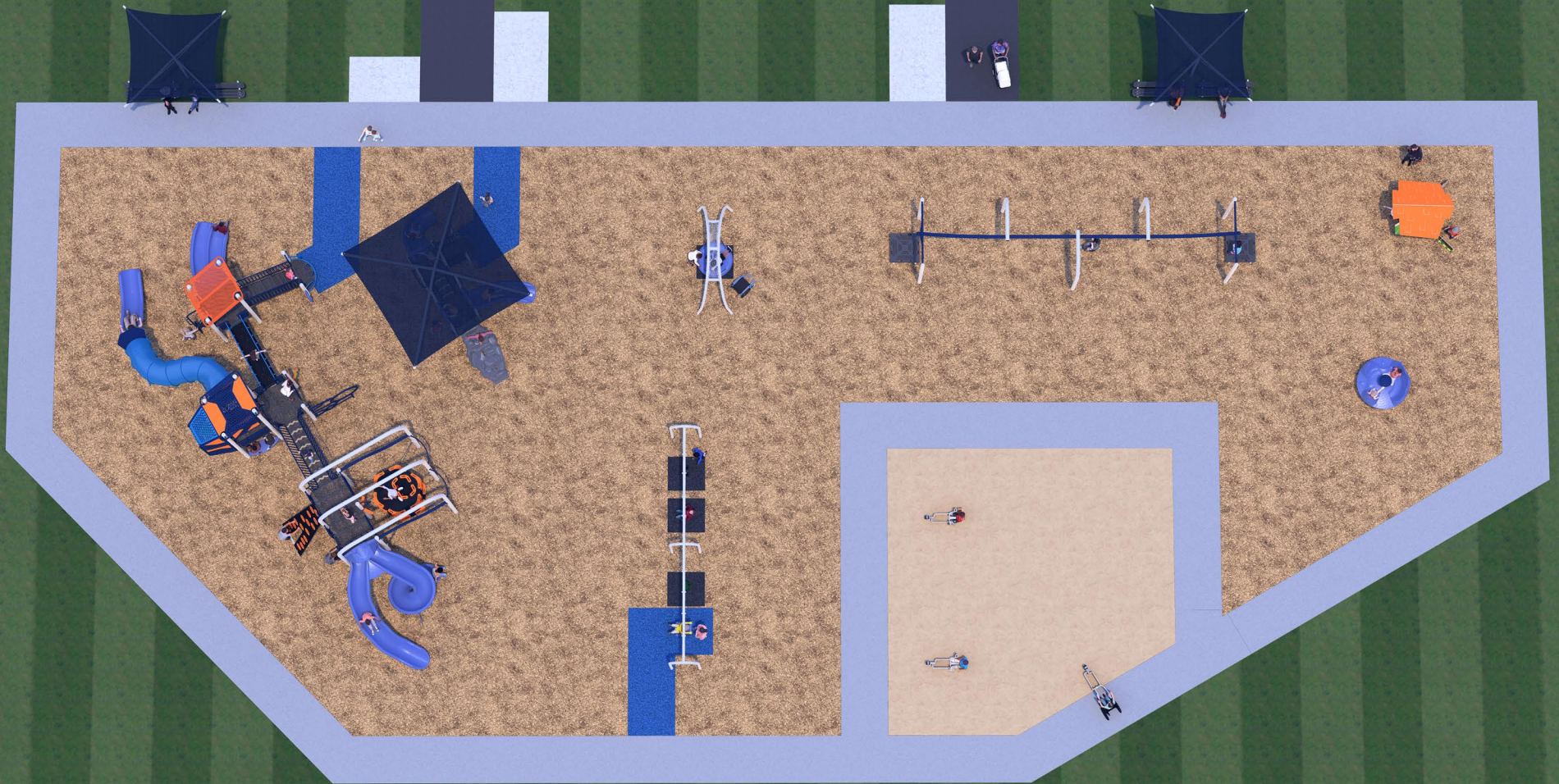

SUNNYSIDE PARK - OPT. 1

Rogers, MN D12924L





CONSULTANT: DAN LANES

RFP Sunnyside Park - Option 1 - Rogers, MN - D12924L - I

City of Rogers
 Attn: Mike Bauer
 22350 S. Diamond Lake Rd.
 Rogers, MN 55374
 United States
 Phone: 763-428-0974
 mbauer@ci.rogers.mn.us

Ship to Zip 55374

Quantity	Part #	Description	Unit Price	Amount
1	LUMP	Other - Drain Tile Installation	\$8,678.25	\$8,678.25
1	INSTALL	Install - Installation of Play Equipment- Includes layout and digging for footings Includes disposal of packing materials	\$41,171.07	\$41,171.07
			Sub Total	\$49,849.32
			Total	\$49,849.32

Comments

Owner is responsible for accepting delivery and storage of play equipment
 Owner is responsible for removal of existing play equipment, safety surfacing, and drainage
 Owner is responsible for providing a flat and level area with less than 1% grade change

This quotation is subject to current MWP Recreation (MWP) policies as well as the following terms and conditions. Our quotation is based on shipment of all items at one time to a single destination, unless noted, and changes are subject to price adjustment. Purchases in excess of \$1,000.00 to be supported by your written purchase order made out to MWP Recreation.

Each quote is handled on a per order/project basis. Unless a long-term agreement is in place between purchaser and MWP, terms and conditions of this quotation shall be as outlined herein with no other requirements applicable.

Any changes made to product and/or services after initial order(s) has/have been received by MWP will result in production and/or schedule time frame modifications. Please contact your regional representative to receive a revised schedule for your order/project.

Indemnification: Owner/Owner's Representative will indemnify and hold Minnesota Playground, Inc., dba, MWP Recreation (MWP), harmless for all claims, damages and related costs, including reasonable legal fees and costs, arising out of Owner/Owner's Representative's negligence or noncompliance with any of its commitments under this document. MWP will indemnify and hold Owner/Owner's Representative harmless for all claims, damages and related costs, including reasonable legal fees and costs, arising out of MWP's negligence or noncompliance with any of its commitments under this document.

Excusable Delays/Additional Costs: MWP, and/or its affiliates, shall be liable for default unless delay of performance, whether supplying materials only or including installation in accordance with our project scope, is caused by an occurrence beyond reasonable control of MWP, and/or its affiliates, such as, but not limited to, acts of Superior Force or the public enemy, acts of Government in either its sovereign or contractual capacity, fire, floods, epidemics, quarantine restrictions, strikes, unusually severe weather, delays of common carriers (for transportation of goods whether raw materials or finished product), attainability of raw materials and severe tariffs. Such events resulting in additional costs are not included in quoted amounts and shall be the responsibility of the Owner/Owner's Representative. Any additional costs shall be provided in writing for purchaser's records and shall be due upon payment of invoice.

Pricing: f.o.b. factory, firm for 15 days from date of quotation. If placing an order after expiration of quote, please contact our office for updated pricing. A tax-exempt certificate is needed at time of order entry for all orders whether from tax-supported government agencies or not. Sales tax, if applicable, will be added at time of invoice unless a tax exempt certificate is provided at time of order entry.





MWP Recreation
4800 Olson Memorial Hwy, Suite 130 Golden Valley, Minnesota 55422
Ph. 800-622-5425 | 763-546-778 | dan@MWPprecreation.com

12/07/2025
Quote #
106743-01-03

CONSULTANT: DAN LANES

RFP Sunnyside Park - Option 1 - Rogers, MN - D12924L - I

Payment terms: net 30 days for tax supported governmental agencies. Should this quotation be forwarded to an agency not listed on this quote, credit terms, as well as other terms and conditions herein, may be need to be altered. For instance, non-tax supported organization purchasing any or all products and/or services quoted herein may require full payment for that amount due at time of order entry. Remaining balance owed by tax supported agency, if any, shall still be net 30 days. A 1.5% per month finance charge will be imposed on all past due accounts. Equipment shall be invoiced separately from other services and shall be payable in advance of those services and project completion. Retainage not accepted.

Installation: shall be by a Certified GameTime Installer. Customer shall be responsible for scheduling coordination and site preparation. Site should be level and permit installation equipment access. Purchaser shall be responsible for unknown conditions such as buried utilities, tree stumps, bedrock or any concealed materials or conditions that may result in additional labor or material costs.





CONSULTANT: DAN LANES

RFP Sunnyside Park - Option 1 - Rogers, MN - D12924L - M

City of Rogers
 Attn: Mike Bauer
 22350 S. Diamond Lake Rd.
 Rogers, MN 55374
 United States
 Phone: 763-428-0974
 mbauer@ci.rogers.mn.us

Ship to Zip 55374

Quantity	Part #	Description	Unit Price	Amount
1	RDU	GameTime - Powerscape Spire Tower Play Unit, Ages 5-12 [Deck:Pvc:_____] [Basic:_____] [RotoPlastic:_____] [2ColorHDPE:_____] [Accent:_____] [MetalRoof:_____] [Accent2:_____] [Cabling:_____] [HDPE:_____] [Tube:_____] [Arch:_____]	\$81,717.00	\$81,717.00
1	RDU	GameTime - Primetime Play Unit, Ages 2-5 [Basic:_____] [Accent:_____] [Deck:Pvc:_____] [RotoPlastic:_____] [UniPlastic:_____] [Accent2:_____] [Fabric1:_____]	\$17,091.50	\$17,091.50
1	RDU	GameTime - Primetime ADA Swing Set [Basic:_____] [RotoPlastic:_____]	\$6,252.00	\$6,252.00
1	5058	GameTime - Arch Swing (Galv) [Basic:_____] [Roto Plastic:_____]	\$7,880.00	\$7,880.00
2	6197	GameTime - Backhoe Digger [Basic:_____]	\$1,645.00	\$3,290.00
1	6198	GameTime - Backhoe Digger, Accessible [Basic:_____]	\$1,671.00	\$1,671.00
1	6372	GameTime - Spin With Me (With Handle) [Accent:_____] [Roto Plastic:_____]	\$7,748.00	\$7,748.00
4	28009	GT-Site - 6' P/S Bench W/Back Inground [Basic:_____] [Coated Site:_____]	\$1,130.00	\$4,520.00
1	39024I	GameTime - Bingo's Playhouse [2 Color HDPE:_____] [2 ColorHDPE2:_____] [Basic:_____] [HDPE:_____]	\$9,904.00	\$9,904.00
1	91778	GameTime - SkyRun Zip Track 35 - Zip Seat [Accent:_____] [Basic:_____] [Deck:Pvc:_____]	\$18,730.00	\$18,730.00
1	178749	GameTime - Owner's Kit	\$98.07	\$98.07





CONSULTANT: DAN LANES

RFP Sunnyside Park - Option 1 - Rogers, MN - D12924L - M

Quantity	Part #	Description	Unit Price	Amount
4	161292	GameTime - Wear Mat 36" x 36"	\$358.00	\$1,432.00
2	QRI433	GT-Shade - HYU101008IG HYPERBOLIC UMB 10X10X8 [Basic: _____] [Fabric 1: _____]	\$4,810.00	\$9,620.00
1	EWf	Other - Engineered Wood Fiber Safety Surfacing- 351 CY 12" depth Includes geo-fabric Includes blow-in	\$21,940.00	\$21,940.00
1	PIP	Other - Poured-in-Place Safety Surfacing- 238 SF 8ft CFH Includes security Includes disposal	\$16,370.00	\$16,370.00
			Sub Total	\$208,263.57
			Freight	\$16,887.11
			Total	\$225,150.68

Comments

Owner is responsible for accepting delivery and storage of play equipment
 Owner is responsible for removal of existing play equipment, safety surfacing, and drainage
 Owner is responsible for providing a flat and level area with less than 1% grade change

This quotation is subject to current MWP Recreation (MWP) policies as well as the following terms and conditions. Our quotation is based on shipment of all items at one time to a single destination, unless noted, and changes are subject to price adjustment. Purchases in excess of \$1,000.00 to be supported by your written purchase order made out to MWP Recreation.

Each quote is handled on a per order/project basis. Unless a long-term agreement is in place between purchaser and MWP, terms and conditions of this quotation shall be as outlined herein with no other requirements applicable.

Any changes made to product and/or services after initial order(s) has/have been received by MWP will result in production and/or schedule time frame modifications. Please contact your regional representative to receive a revised schedule for your order/project.

Indemnification; Owner/Owner's Representative will indemnify and hold Minnesota Playground, Inc., dba, MWP Recreation (MWP), harmless for all claims, damages and related costs, including reasonable legal fees and costs, arising out of Owner/Owner's Representative's negligence or noncompliance with any of its commitments under this document. MWP will indemnify and hold Owner/Owner's Representative harmless for all claims, damages and related costs, including reasonable legal fees and costs, arising out of MWP's negligence or noncompliance with any of its commitments under this document.

Excusable Delays/Additional Costs: MWP, and/or its affiliates, shall be liable for default unless delay of performance, whether supplying materials only or including installation in accordance with our project scope, is caused by an occurrence beyond reasonable control of MWP, and/or its affiliates, such as, but not limited to, acts of Superior Force or the public enemy, acts of Government in either its sovereign or contractual capacity, fire, floods, epidemics, quarantine restrictions, strikes, unusually severe weather, delays of common carriers (for transportation of goods whether raw materials or finished product), attainability of raw materials and severe tariffs. Such events resulting in additional costs are not included in quoted amounts and shall be the responsibility of the Owner/Owner's Representative. Any additional costs shall be provided in writing for purchaser's records and shall be due upon payment of invoice.





MWP Recreation
4800 Olson Memorial Hwy, Suite 130 Golden Valley, Minnesota 55422
Ph. 800-622-5425 | 763-546-778 | dan@MWPPrecreation.com

12/07/2025
Quote #
106743-01-02

CONSULTANT: DAN LANES

RFP Sunnyside Park - Option 1 - Rogers, MN - D12924L - M

This quotation is subject to polices in the current GameTime Park and Playground catalog and the following terms and conditions. Our quotation is based on shipment of all items at one time to a single destination, unless noted, and changes are subject to price adjustment. Purchases in excess of \$1,000.00 to be supported by your written purchase order made out to GameTime, c/o MWP Recreation.

Each quote is handled on a per order/project basis. Unless a long-term agreement is in place between purchaser and GameTime, terms and conditions of this quotation shall be as outlined herein with no other requirements applicable.

Any changes made to product and/or services after initial order(s) has/have been received by GameTime will result in production and/or schedule time frame modifications. Please contact your regional representative to receive a revised schedule for your order/project.

Pricing: f.o.b. factory, firm for 15 days from date of quotation. If placing an order after expiration of quote, please contact our office for updated pricing. A tax-exempt certificate is needed at time of order entry for all orders whether from tax-supported government agencies or not. Sales tax, if applicable, will be added at time of invoice unless a tax exempt certificate is provided at time of order entry.

Payment terms: net 30 days for tax supported governmental agencies. Should this quotation be forwarded to an agency not listed on this quote, credit terms, as well as other terms and conditions herein, may be need to be altered. For instance, non-tax supported organization purchasing any or all products and/or services quoted herein may require full payment for that amount due at time of order entry. Remaining balance owed by tax supported agency, if any, shall still be net 30 days. A 1.5% per month finance charge will be imposed on all past due accounts. Equipment shall be invoiced separately from other services and shall be payable in advance of those services and project completion. Retainage not accepted.

Unless already on file, please include a tax exempt certificate upon order entry whether a tax supported government agency or other.

GameTime Standard Product Shipment: order shall ship within six to eight weeks after GameTime's receipt and acceptance of your purchase order, color selections, approved submittals, if required, and receipt of deposit, if required. Receipt of anything other than what is stated herein will not constitute an order and therefore no materials will be placed into production nor installation, if required, will be scheduled.

Freight charges: Prepaid & added





A PLAYFORMS Company

Color Palette: Whimsy Way

- Uprights: White
- Accent: Blue
- Accent 2: Sky Blue
- 2-Color HDPE: Spring Green/White
- 2-Color 2: Orange/White
- HDPE: Orange
- Deck: Gray
- Roto Plastic: Periwinkle
- Tube: Sky Blue
- Cabling: Black
- Uni Plastic: Deep Granite
- Metal Roof: Orange
- Fabric: Navy Blue
- Coated Site: Gray
- PIP: 50-50 Bright Blue/Black



SUNNYSIDE PARK - OPT. 2

Rogers, MN D12925L





SUNNYSIDE PARK - OPT. 2
Rogers, MN D12925L





SUNNYSIDE PARK - OPT. 2
Rogers, MN D12925L





SUNNYSIDE PARK - OPT. 2
Rogers, MN D12925L





SUNNYSIDE PARK - OPT. 2

Rogers, MN D12925L



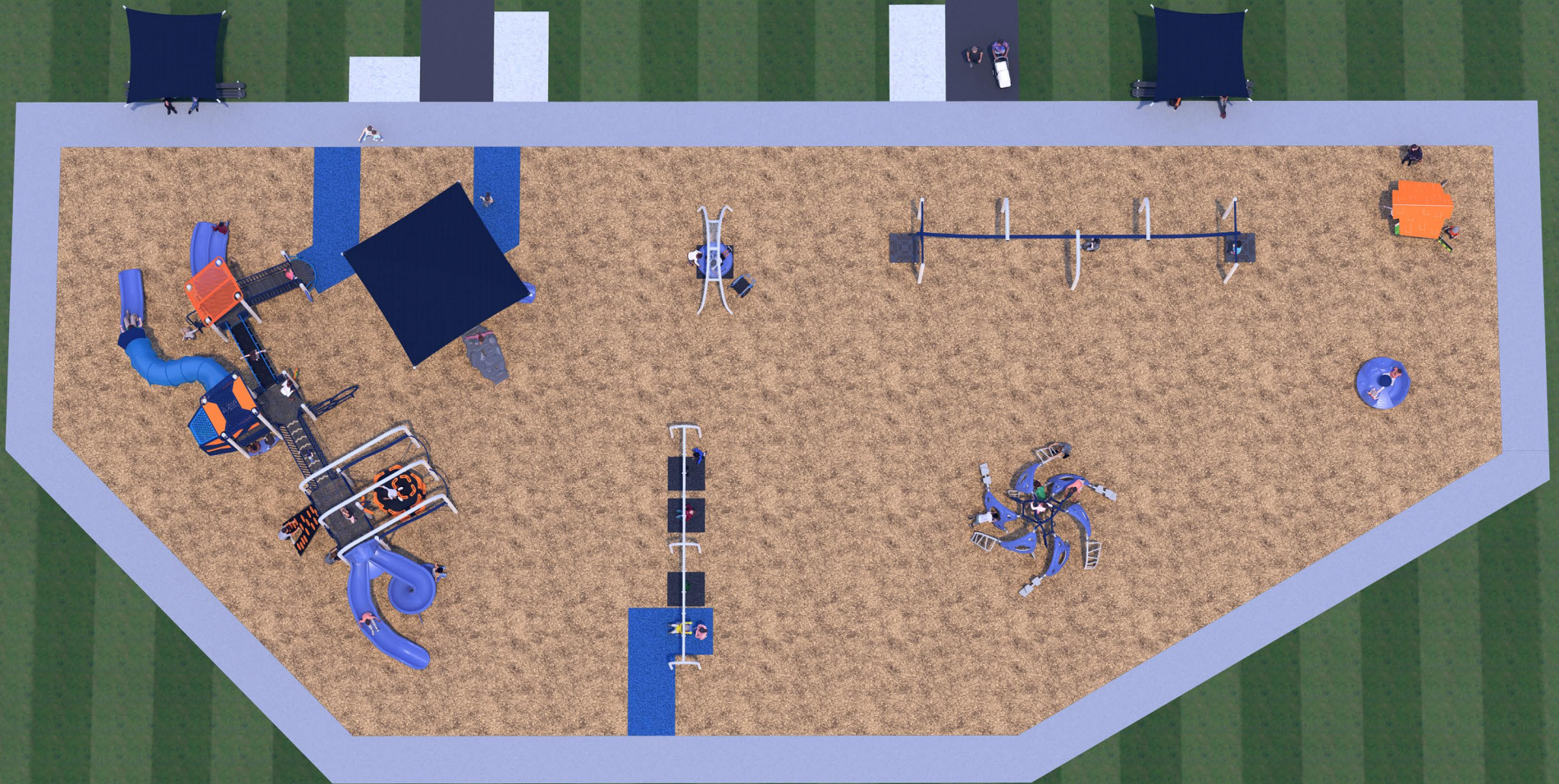

SUNNYSIDE PARK - OPT. 2

Rogers, MN D12925L



Please Sign & Date the Final Top View:

While it is our intention to install your playground in a safe and timely manner, our success relies on your preparedness. Site preparation and grading to be performed by others and prior to installation. Slope within the play area(s) shall not exceed 1% to ensure a successful installation and a compliant playground. Drain tile systems other than within 4' of the perimeter along drain aggregate base material may require installing after the installation of the play equipment and must be coordinated with installation of safety surface materials. Failure to prepare site(s) to these expectations may result in additional charges if installer is required to re-mobilize. Please contact MN WI Playground if you have any questions.

Maximum depth of safety surface and drain aggregate base should not exceed an 18" depth and shall not be installed until play equipment has been installed.

EXISTING SITE FURNISHINGS

POURED-IN-PLACE SAFETY SURFACING
238 SF TOTAL

EXISTING SIDEWALK

- TUFFCLAD 6' BENCH w/BACK IN-GROUND (PS) 28009
- 6' HYPERBOLIC UMBRELLA 10' x 10' (HYU101008IG) ORI433
- TUFFCLAD 6' BENCH w/BACK IN-GROUND (PS) 28009

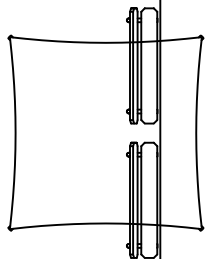

ADA REQUIREMENTS FOR STRUCTURE AGES 5-12 YEARS OLD AGES 2-5 YEARS OLD

TOTAL NUMBER OF ELEVATED PLAY COMPONENTS	IN PLAN 12	REQ'D. 6	IN PLAN 6	REQ'D. 3
TOTAL EVENTS ACCESSIBLE VIA TRANSFER	IN PLAN 11	REQ'D. 0	IN PLAN 6	REQ'D. 0
TOTAL ACCESSIBLE EVENTS VIA RAMP	IN PLAN 0	REQ'D. 0	IN PLAN 0	REQ'D. 0
TOTAL ACCESSIBLE GROUND LEVEL EVENTS	IN PLAN 10	REQ'D. 4	IN PLAN 4	REQ'D. 2
DIFFERENT TYPES OF GROUND LEVEL EVENTS	IN PLAN 7	REQ'D. 3	IN PLAN 3	REQ'D. 2

THIS PLAYGROUND MEETS ALL CURRENT ADA REQUIREMENTS & THE FINAL RULE ABOVE CHART/INFO IS APPLICABLE WHEN USING AN ACCESSIBLE SAFETY SURFACE

SCALE: 1" = 10'-0"



Sold & Distributed By:



P.O. Box 27328, Golden Valley, MN 55427
763-546-7787 1-800-622-5425
Fax 763-546-5050
E-Mail info@mwprecreation.com

THIS PLAN REQUIRES A FINISHED GRADE RESOLUTION

Sunnyside Park - Option 2

Rogers, MN

12-2-25

DWG. D12925L

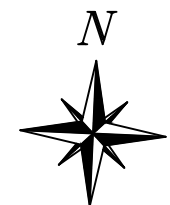
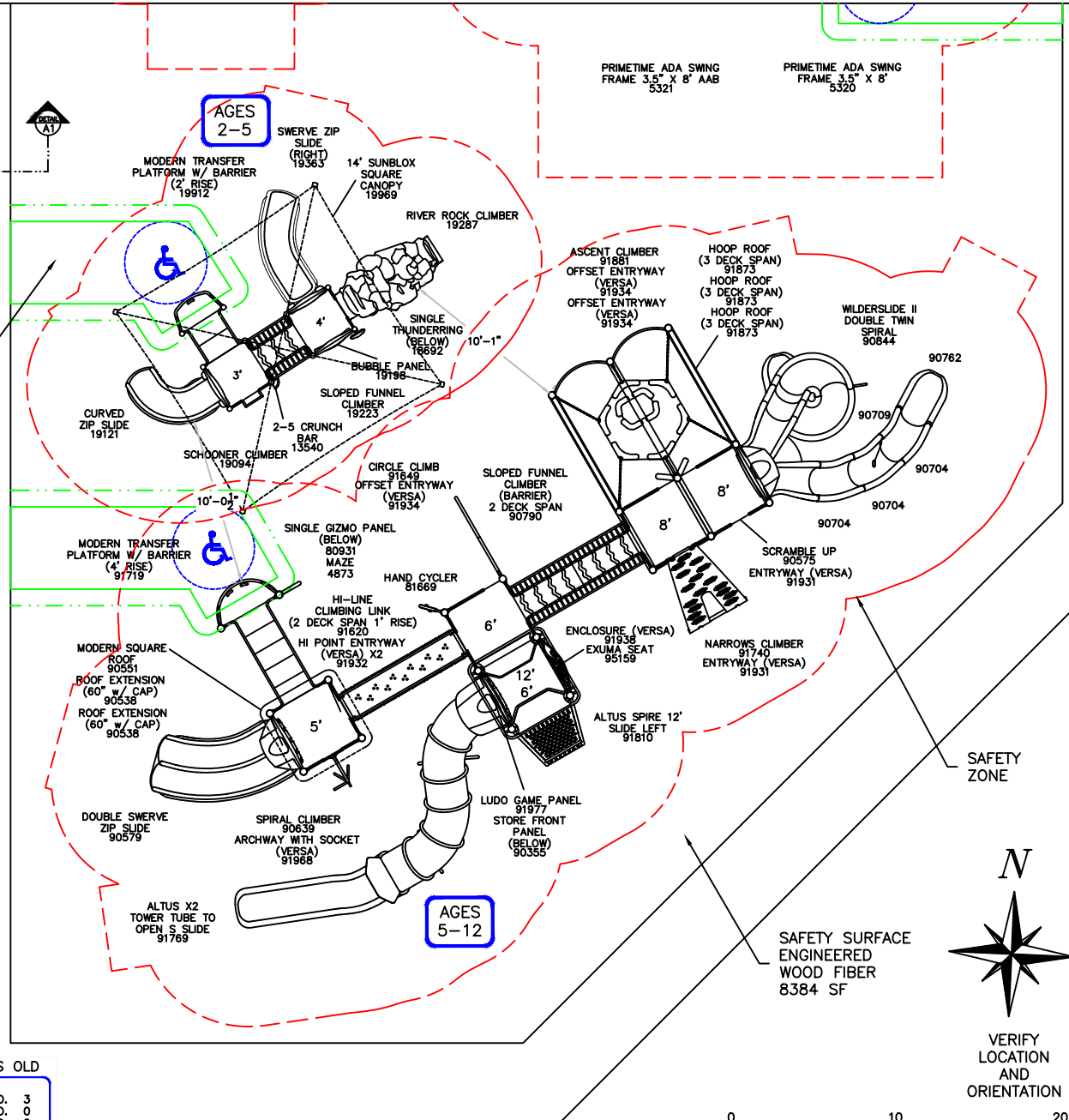

VERIFY LOCATION AND ORIENTATION



SCALE IN FEET

While it is our intention to install your playground in a safe and timely manner, our success relies on your preparedness. Site preparation and grading to be performed by others and prior to installation. Slope within the play area(s) shall not exceed 1% to ensure a successful installation and a compliant playground. Drain tile systems other than within 4' of the perimeter along drain aggregate base material may require installing after the installation of the play equipment and must be coordinated with installation of safety surface materials. Failure to prepare site(s) to these expectations may result in additional charges if installer is required to re-mobilize. Please contact MN WI Playground if you have any questions.

Maximum depth of safety surface and drain aggregate base should not exceed an 18" depth and shall not be installed until play equipment has been installed.

- TUFFCLAD 6' BENCH w/ BACK IN-GROUND (PS) 28009
- 8' HYPERBOLIC UMBRELLA 10' x 10' (HYU101008IG) QR433
- TUFFCLAD 6' BENCH w/ BACK IN-GROUND (PS) 28009

EXISTING SIDEWALK

EXISTING SITE FURNISHINGS

SAFETY ZONE

Please Sign & Date the Final Top View:

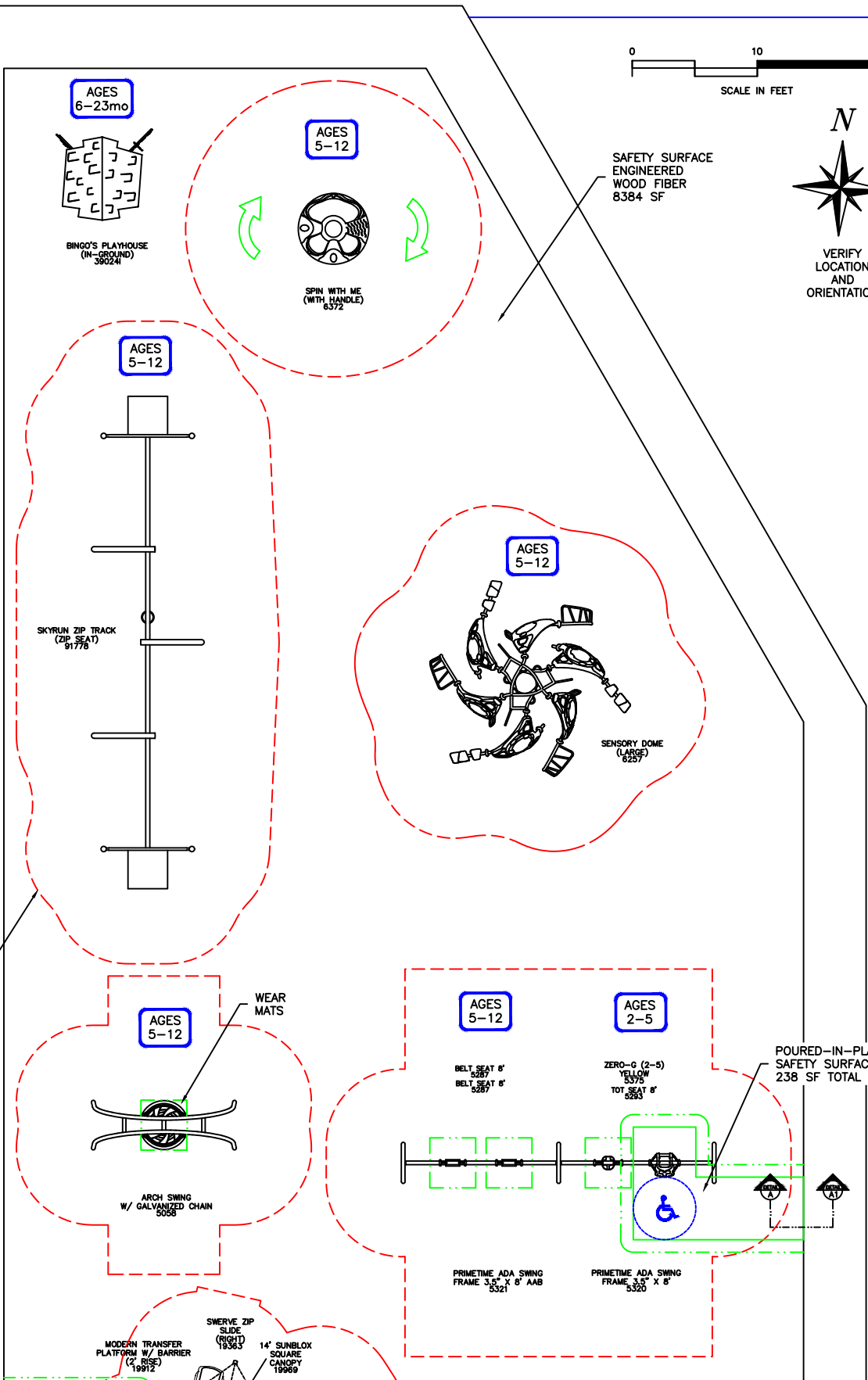
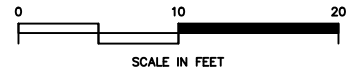

Mfg. By:
PLAYCORE COMPANY
recreation
Enriching Childhood Through Play.

Sold & Distributed By:
recreation
P.O. Box 27328, Golden Valley, MN 55427
763-546-7787 1-800-622-5425
Fax 763-546-5050
E-Mail info@mwprecreation.com

Sunnyside Park - Option 2
Rogers, MN
12-2-25
DWG. D12925L

THIS PRINT IS THE PROPERTY OF MINNESOTA WISCONSIN PLAYGROUND INC. AND IS NOT TO BE USED, COPIED OR REPRODUCED WITHOUT THEIR EXPRESSED WRITTEN PERMISSION. SCALE: 1" = 12'-0"

Please Sign & Date the Final Top View:

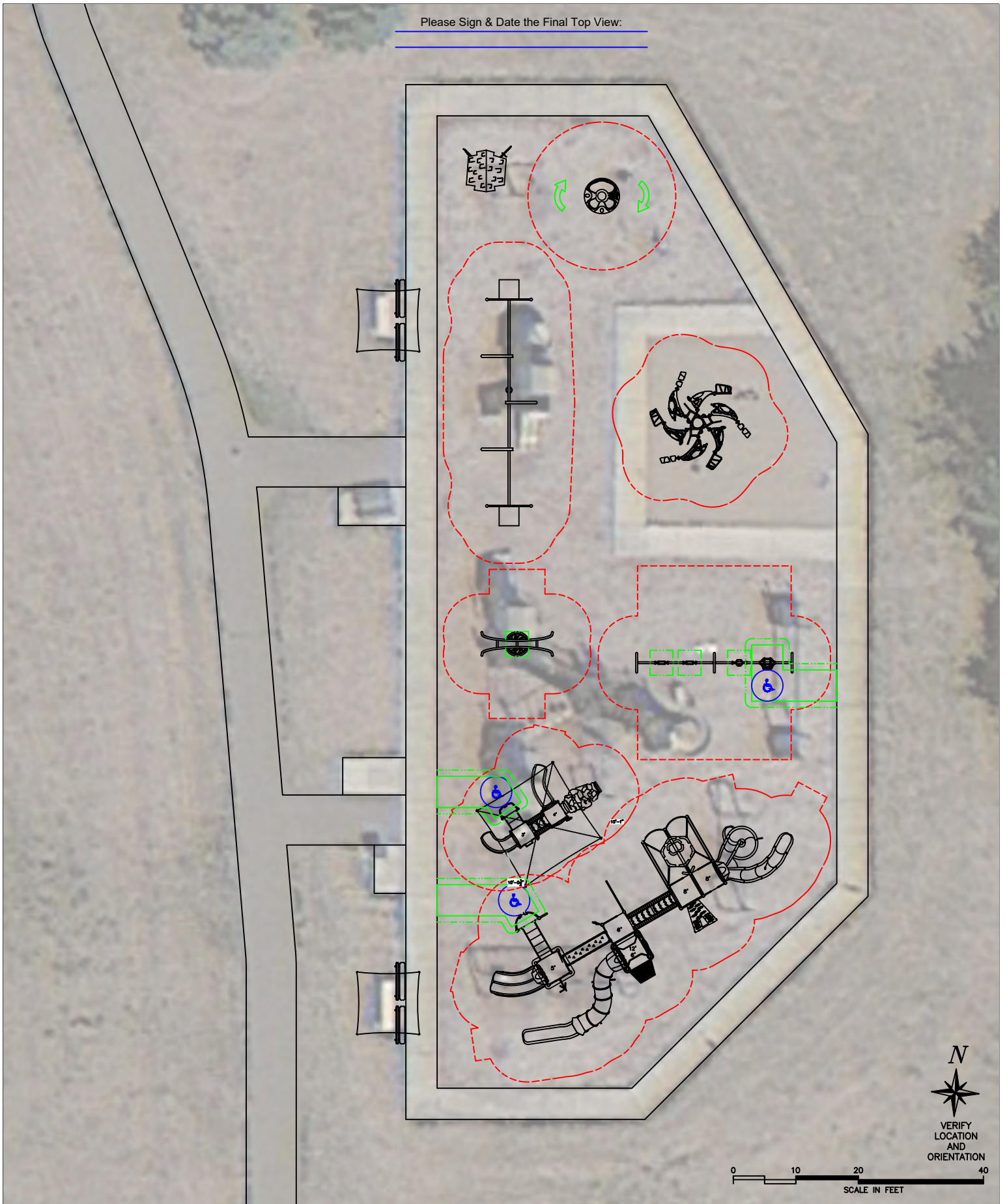

Mfg. By:

 Enriching Childhood Through Play.

Sold & Distributed By:

recreation
 P.O. Box 27328, Golden Valley, MN 55427
 763-546-7787 1-800-622-5425
 Fax 763-546-5050
 E-Mail info@mwprecreation.com

Sunnyside Park - Option 2
 Rogers, MN
 12-2-25 DWG. D12925L

THIS PRINT IS THE PROPERTY OF MINNESOTA WISCONSIN PLAYGROUND INC. AND IS NOT TO BE USED, COPIED OR REPRODUCED WITHOUT THEIR EXPRESSED WRITTEN PERMISSION. SCALE: 1" = 20'-0"



CONSULTANT: DAN LANES

RFP Sunnyside Park - Option 2 - Rogers, MN - D12925L - I

City of Rogers
Attn: Mike Bauer
22350 S. Diamond Lake Rd.
Rogers, MN 55374
United States
Phone: 763-428-0974
mbauer@ci.rogers.mn.us

Ship to Zip 55374

Quantity	Part #	Description	Unit Price	Amount
1	LUMP	Other - Drain Tile Installation	\$7,650.00	\$7,650.00
1	INSTALL	Install - Installation of Play Equipment- Includes layout and digging for footings Includes disposal of packing materials	\$44,304.09	\$44,304.09
			Sub Total	\$51,954.09
			Total	\$51,954.09

Comments

Owner is responsible for accepting delivery and storage of play equipment
Owner is responsible for removal of existing play equipment, safety surfacing, and drainage
Owner is responsible for providing a flat and level area with less than 1% grade change

This quotation is subject to current MWP Recreation (MWP) policies as well as the following terms and conditions. Our quotation is based on shipment of all items at one time to a single destination, unless noted, and changes are subject to price adjustment. Purchases in excess of \$1,000.00 to be supported by your written purchase order made out to MWP Recreation.

Each quote is handled on a per order/project basis. Unless a long-term agreement is in place between purchaser and MWP, terms and conditions of this quotation shall be as outlined herein with no other requirements applicable.

Any changes made to product and/or services after initial order(s) has/have been received by MWP will result in production and/or schedule time frame modifications. Please contact your regional representative to receive a revised schedule for your order/project.

Indemnification: Owner/Owner's Representative will indemnify and hold Minnesota Playground, Inc., dba, MWP Recreation (MWP), harmless for all claims, damages and related costs, including reasonable legal fees and costs, arising out of Owner/Owner's Representative's negligence or noncompliance with any of its commitments under this document. MWP will indemnify and hold Owner/Owner's Representative harmless for all claims, damages and related costs, including reasonable legal fees and costs, arising out of MWP's negligence or noncompliance with any of its commitments under this document.

Excusable Delays/Additional Costs: MWP, and/or its affiliates, shall be liable for default unless delay of performance, whether supplying materials only or including installation in accordance with our project scope, is caused by an occurrence beyond reasonable control of MWP, and/or its affiliates, such as, but not limited to, acts of Superior Force or the public enemy, acts of Government in either its sovereign or contractual capacity, fire, floods, epidemics, quarantine restrictions, strikes, unusually severe weather, delays of common carriers (for transportation of goods whether raw materials or finished product), attainability of raw materials and severe tariffs. Such events resulting in additional costs are not included in quoted amounts and shall be the responsibility of the Owner/Owner's Representative. Any additional costs shall be provided in writing for purchaser's records and shall be due upon payment of invoice.

Pricing: f.o.b. factory, firm for 15 days from date of quotation. If placing an order after expiration of quote, please contact our office for updated pricing. A tax-exempt certificate is needed at time of order entry for all orders whether from tax-supported government agencies or not. Sales tax, if applicable, will be added at time of invoice unless a tax exempt certificate is provided at time of order entry.





MWP Recreation
4800 Olson Memorial Hwy, Suite 130 Golden Valley, Minnesota 55422
Ph. 800-622-5425 | 763-546-778 | dan@MWPrecreation.com

12/08/2025
Quote #
106743-01-06

CONSULTANT: DAN LANES

RFP Sunnyside Park - Option 2 - Rogers, MN - D12925L - I

Payment terms: net 30 days for tax supported governmental agencies. Should this quotation be forwarded to an agency not listed on this quote, credit terms, as well as other terms and conditions herein, may be need to be altered. For instance, non-tax supported organization purchasing any or all products and/or services quoted herein may require full payment for that amount due at time of order entry. Remaining balance owed by tax supported agency, if any, shall still be net 30 days. A 1.5% per month finance charge will be imposed on all past due accounts. Equipment shall be invoiced separately from other services and shall be payable in advance of those services and project completion. Retainage not accepted.

Unless already on file, please include a tax exempt certificate upon order entry whether a tax supported government agency or other.

Installation: shall be by a Certified GameTime Installer. Customer shall be responsible for scheduling coordination and site preparation. Site should be level and permit installation equipment access. Purchaser shall be responsible for unknown conditions such as buried utilities, tree stumps, bedrock or any concealed materials or conditions that may result in additional labor or material costs.





CONSULTANT: DAN LANES

RFP Sunnyside Park - Option 2 - Rogers, MN - D12925L - I

Project Scope:

Please note, installation is based on site being ready prior to our arrival to install play equipment as well as site conditions that have been conveyed to our organization by the owner/owner's representative and/or ideal conditions existing for a timely completion of your project as quoted. Unless addressed prior to the installation quote being issued or specifically mentioned herein, any issues that arise that impede the progress/completion of your project as quoted will result in additional charges.

Weather can change project scheduling in many ways. Take rain for an example. Day, or days, before rain... If weather forecasts show a high percentage chance for rain that will effect the site conditions, a postponement may be in order. Digging holes, laying certain surfacing materials, etc., are greatly affected by weather conditions and work may not begin/continue due to weather forecasts. There's the rain days themselves, which if heavy enough rainfall occurs, makes a site unworkable. Day, or days, after rain... Drying time will be needed after rain and the number of days needed will vary depending on amount of moisture received. One actual rain day may equal multiple delay days depending on work scheduled to be done.

+ INCLUSIONS +

- + One mobilization
- + Public utility locates only
- + Installation of equipment as outlined on quote #106743-01-05
- + Marking and digging of footings holes to accept direct embedment supports as needed
- + Unpacking of play equipment
- + Assembly of play equipment
- + Concrete for footings as needed
- + Pouring of concrete for footings
- + Engineered wood fiber (EWF) surfacing
- + Spreading of EWF
- + Poured-in-place safety surfacing
- + Drain tile
- + Construction tape/temporary bracing (as needed)
- + Standard insurance offerings
- + Standard warranty offerings
- + Standard industry accepted labor wages
- + Disposal of packing material

- EXCLUSIONS -

- Clear access path up to and into play area for installation equipment (minimum of 8-foot wide, includes but not limited to gates, walkways, driveways, etc.)
- Staging area for materials and installation equipment, trailers, etc.
- Unobstructed space for maneuvering installation equipment as well as performing work
- Security fencing of any type
- On site security personnel
- If fencing is in place (by others), ability to unlock fencing is to be provided to our office a minimum of one week prior to our start
- Private utility locates such as, but not limited to, irrigation, fiber optics, private lighting, etc.
- Accepting, unloading and storage of order(s)/shipment(s) prior to installation. Please note, orders can be packaged/shipped in large crates, pallets, etc., requiring heavy-duty equipment to unload.
- Sitework of any kind such as, but not limited to, grading (play area to have max slope of 1%), site restoration, drainage, etc.
- Removal of existing play equipment, border, safety surfacing, etc.
- Backfill and compaction of backfill after removal of existing items (for footing holes as an example) that leave voids in area (marking and digging of new footing holes based on workable site)
- Digging in compacted sub-surfaces, rock, hard pan, tree roots, unstable soil conditions, etc.
- Restoration of compacted sub-surfaces for playground surfacings such as, but not limited to, poured-in-place rubber, rubber tiles, artificial turf, etc.
- Digging/maneuvering in sand, pea gravel, mud, etc.
- Offsite removal of spoils from footing holes (can be stockpiled near play area for owner/owner's representative removal or spread within play area)
- Border to help contain playground safety surfacing





CONSULTANT: DAN LANES

RFP Sunnyside Park - Option 2 - Rogers, MN - D12925L - I

- Removal of temporary braces, caution/construction tape, etc. (Can be removed and disposed of after concrete has cured.)
- Bonding of any type
- Permits of any kind
- Prevailing, Davis Bacon, Union, or similar, wages
- Restroom facilities. Please provide access to restrooms whether within a building or portable style. Should use of site facilities not be available, additional charges will be required to bring on site temporary/portable restrooms. These temporary facilities will be removed once your project has been completed.
- Short term maintenance, check manufacturer's owner's manual recommendations for maintenance and always follow these written instructions. To help set up short (and ongoing) term maintenance, use the first twelve months to regularly check equipment (such as, but not limited to, tightening hardware, checking moving features, etc.). Twelve months allows use in all seasons and will provide a better understanding of what will be necessary for your ongoing maintenance. This short term schedule will be based on the amount of use the play equipment is getting as well as the type of play event that is being played on. Activities with movement have a more dynamic play which can lead to more maintenance due to the nature of the motion but also because these types of play events tend to be more popular. Static features may require less attention during the short term and ongoing maintenance as inspections will determine frequency of maintenance needed for these events. There may be a need for scheduled lower and higher frequency inspections.
- Ongoing maintenance, check manufacturer's owner's manual recommendations for maintenance and always follow these written instructions. After short term maintenance period is done and data is collected for that time period, an ongoing schedule should be implemented. The ongoing maintenance can change with age and greater use. There may be a need for scheduled lower and higher frequency inspections.

Should weekend work be necessary or non-standard hours be worked, please provide a site contact and the best telephone number to reach this person in case an urgent matter arises requiring immediate attention.

(Name) _____
(Cell) _____
(Other Telephone Number) _____

Wet Site Conditions: installation areas located near wetlands, where a high water table exists or in any environment that produces excessive moisture will require additional planning prior to installation of your project. Unless excessively wet conditions have been conveyed prior to installation quote and accounted for in some manner, your installation will not proceed. Ideal dry conditions need to be present to begin, and complete, your project as quoted.

Exclusions: unless specifically included, this quotation excludes all site work and landscaping; removal of existing equipment; acceptance of equipment and off-loading; storage of goods prior to installation; equipment assembly and installation; safety surfacing; borders and drainage provisions.

Order Information:

Bill To: _____ Ship To: _____
Company: _____ Project Name: _____
Attn: _____ Attn: _____
Address: _____ Address: _____
City, State, Zip: _____ City, State, Zip: _____
Contact: _____ Contact: _____
Tel: _____ Tel: _____
Fax: _____ Fax: _____
Email: _____ Email: _____





MWP Recreation
4800 Olson Memorial Hwy, Suite 130 Golden Valley, Minnesota 55422
Ph. 800-622-5425 | 763-546-778 | dan@MWPprecreation.com

12/08/2025
Quote #
106743-01-06

CONSULTANT: DAN LANES

RFP Sunnyside Park - Option 2 - Rogers, MN - D12925L - I

Acceptance of quotation:

Accepted By (printed): _____ P.O. No: _____

Signature: _____ Date: _____

Title: _____ Phone: _____

Facsimile: _____ Purchase Amount: **\$51,954.09**





CONSULTANT: DAN LANES

RFP Sunnyside Park - Option 2 - Rogers, MN - D12925L - M

City of Rogers
 Attn: Mike Bauer
 22350 S. Diamond Lake Rd.
 Rogers, MN 55374
 United States
 Phone: 763-428-0974
 mbauer@ci.rogers.mn.us

Ship to Zip 55374

Quantity	Part #	Description	Unit Price	Amount
1	RDU	GameTime - Powerscape Spire Tower Play Unit, Ages 5-12 [Deck:Pvc:_____] [Basic:_____] [RotoPlastic:_____] [2ColorHDPE:_____] [Accent:_____] [MetalRoof:_____] [Accent2:_____] [Cabling:_____] [HDPE:_____] [Tube:_____] [Arch:_____]	\$81,717.00	\$81,717.00
1	RDU	GameTime - Primetime Play Unit, Ages 2-5 [Basic:_____] [Accent:_____] [Deck:Pvc:_____] [RotoPlastic:_____] [UniPlastic:_____] [Accent2:_____] [Fabric1:_____]	\$17,091.50	\$17,091.50
1	RDU	GameTime - Primetime ADA Swing Set [Basic:_____] [RotoPlastic:_____]	\$6,252.00	\$6,252.00
1	5058	GameTime - Arch Swing (Galv) [Basic:_____] [Roto Plastic:_____]	\$7,880.00	\$7,880.00
1	6257	GameTime - Sensory Dome - Large [Accent:_____] [Basic:_____] [Roto Plastic:_____]	\$23,866.00	\$23,866.00
1	6372	GameTime - Spin With Me (With Handle) [Accent:_____] [Roto Plastic:_____]	\$7,748.00	\$7,748.00
4	28009	GT-Site - 6' P/S Bench W/Back Inground [Basic:_____] [Coated Site:_____]	\$1,130.00	\$4,520.00
1	39024I	GameTime - Bingo's Playhouse [2 Color HDPE:_____] [2 ColorHDPE2:_____] [Basic:_____] [HDPE:_____]	\$9,904.00	\$9,904.00
1	91778	GameTime - SkyRun Zip Track 35 - Zip Seat [Accent:_____] [Basic:_____] [Deck:Pvc:_____]	\$18,730.00	\$18,730.00
1	178749	GameTime - Owner's Kit	\$98.07	\$98.07
4	161292	GameTime - Wear Mat 36" x 36"	\$358.00	\$1,432.00





CONSULTANT: DAN LANES

RFP Sunnyside Park - Option 2 - Rogers, MN - D12925L - M

Quantity	Part #	Description	Unit Price	Amount
2	QRI433	GT-Shade - HYU101008IG HYPERBOLIC UMB 10X10X8 [Basic: _____] [Fabric 1: _____]	\$4,810.00	\$9,620.00
1	EWf	Other - Engineered Wood Fiber Safety Surfacing- 400 CY 12" depth Includes geo-fabric Includes blow-in	\$25,000.00	\$25,000.00
1	PIP	Other - Poured-in-Place Safety Surfacing- 238 SF 8ft CFH Includes security Includes disposal	\$16,370.00	\$16,370.00
			Sub Total	\$230,228.57
			Freight	\$17,817.34
			Total	\$248,045.91

Comments

Owner is responsible for accepting delivery and storage of play equipment
 Owner is responsible for removal of existing play equipment, safety surfacing, and drainage
 Owner is responsible for providing a flat and level area with less than 1% grade change

This quotation is subject to current MWP Recreation (MWP) policies as well as the following terms and conditions. Our quotation is based on shipment of all items at one time to a single destination, unless noted, and changes are subject to price adjustment. Purchases in excess of \$1,000.00 to be supported by your written purchase order made out to MWP Recreation.

Each quote is handled on a per order/project basis. Unless a long-term agreement is in place between purchaser and MWP, terms and conditions of this quotation shall be as outlined herein with no other requirements applicable.

Any changes made to product and/or services after initial order(s) has/have been received by MWP will result in production and/or schedule time frame modifications. Please contact your regional representative to receive a revised schedule for your order/project.

Indemnification; Owner/Owner's Representative will indemnify and hold Minnesota Playground, Inc., dba, MWP Recreation (MWP), harmless for all claims, damages and related costs, including reasonable legal fees and costs, arising out of Owner/Owner's Representative's negligence or noncompliance with any of its commitments under this document. MWP will indemnify and hold Owner/Owner's Representative harmless for all claims, damages and related costs, including reasonable legal fees and costs, arising out of MWP's negligence or noncompliance with any of its commitments under this document.

Excusable Delays/Additional Costs: MWP, and/or its affiliates, shall be liable for default unless delay of performance, whether supplying materials only or including installation in accordance with our project scope, is caused by an occurrence beyond reasonable control of MWP, and/or its affiliates, such as, but not limited to, acts of Superior Force or the public enemy, acts of Government in either its sovereign or contractual capacity, fire, floods, epidemics, quarantine restrictions, strikes, unusually severe weather, delays of common carriers (for transportation of goods whether raw materials or finished product), attainability of raw materials and severe tariffs. Such events resulting in additional costs are not included in quoted amounts and shall be the responsibility of the Owner/Owner's Representative. Any additional costs shall be provided in writing for purchaser's records and shall be due upon payment of invoice.





MWP Recreation
4800 Olson Memorial Hwy, Suite 130 Golden Valley, Minnesota 55422
Ph. 800-622-5425 | 763-546-778 | dan@MWPRecreation.com

12/08/2025
Quote #
106743-01-05

CONSULTANT: DAN LANES

RFP Sunnyside Park - Option 2 - Rogers, MN - D12925L - M

This quotation is subject to polices in the current GameTime Park and Playground catalog and the following terms and conditions. Our quotation is based on shipment of all items at one time to a single destination, unless noted, and changes are subject to price adjustment. Purchases in excess of \$1,000.00 to be supported by your written purchase order made out to GameTime, c/o MWP Recreation.

Each quote is handled on a per order/project basis. Unless a long-term agreement is in place between purchaser and GameTime, terms and conditions of this quotation shall be as outlined herein with no other requirements applicable.

Any changes made to product and/or services after initial order(s) has/have been received by GameTime will result in production and/or schedule time frame modifications. Please contact your regional representative to receive a revised schedule for your order/project.

Pricing: f.o.b. factory, firm for 15 days from date of quotation. If placing an order after expiration of quote, please contact our office for updated pricing. A tax-exempt certificate is needed at time of order entry for all orders whether from tax-supported government agencies or not. Sales tax, if applicable, will be added at time of invoice unless a tax exempt certificate is provided at time of order entry.

Payment terms: net 30 days for tax supported governmental agencies. Should this quotation be forwarded to an agency not listed on this quote, credit terms, as well as other terms and conditions herein, may be need to be altered. For instance, non-tax supported organization purchasing any or all products and/or services quoted herein may require full payment for that amount due at time of order entry. Remaining balance owed by tax supported agency, if any, shall still be net 30 days. A 1.5% per month finance charge will be imposed on all past due accounts. Equipment shall be invoiced separately from other services and shall be payable in advance of those services and project completion. Retainage not accepted.

Unless already on file, please include a tax exempt certificate upon order entry whether a tax supported government agency or other.

GameTime Standard Product Shipment: order shall ship within six to eight weeks after GameTime's receipt and acceptance of your purchase order, color selections, approved submittals, if required, and receipt of deposit, if required. Receipt of anything other than what is stated herein will not constitute an order and therefore no materials will be placed into production nor installation, if required, will be scheduled.

Freight charges: Prepaid & added





CONSULTANT: DAN LANES

RFP Sunnyside Park - Option 2 - Rogers, MN - D12925L - M

Poured-In-Place Surfacing:

1. See product specifications for specific detailed product information, installation information, compliance documentation, and appropriate certifications. Standard warranty included unless otherwise noted.
2. Quote is based on the information provided and is subject to change based on final installation unless indicated otherwise, in writing. Any changes or additions to this proposal, to include materials, will affect pricing.
3. Sub-base provided by others is the responsibility of the owner and/or others. The substrate must meet & specifications including drainage and grade requirements. There is no demolition or site-work included in the scope of this quote unless otherwise noted above.
4. Site access must be a minimum of 25' for trucks and mixer, with no stairs. Irrigation, sprinkler, and/or water systems must be shut off 24 hours before install and remain off until 24 hours after installation is complete.
5. Additional charges for downtime/stand-by may be assessed in the event that installation is delayed due to the site not being ready as scheduled or if installation is interrupted for reasons other than those related to weather or general public emergencies.
6. Security and waste removal during install and upon completion is the responsibility of the owner, unless specified otherwise in Project Scope.
7. Installations scheduled after 6 months of proposal acceptance may be subject to price adjustments.
8. Normal lead time is 4 weeks from order date. However, scheduling and crew deployment is subject to local weather conditions including temperature and precipitation constraints. See appropriate specification for temperature and precipitation constraints.
9. The scope of this quote does not include on-site fall attenuation testing. We do have independent laboratory testing available upon request.
10. We are not responsible for the reviewing and interpreting of contracts unless approved by Director of Surfacing or otherwise noted in the Project Scope.

Installation Exclusions, unless otherwise noted herein; Permits/Licensing, State or Federal (Davis Bacon) Wages, Demolition, Builders Risk Insurance, Union Fees (PLA/PSA Contracts), Drainage, Additionally Insured, Engineering, Waste/Dumpsters, OCIP, Fall Height/Attenuation Testing, Rooftop Installations, Waiver of Subrogation, Fencing/Security, Extended Warranty, Bonding, Excavation and Site Work/Preparation, Site Restoration.

The following is a non-inclusive list of items that may result in additional charges (Change Order) where work cannot commence until Change Order(s) are fully executed.

- Sub Base not to installation standards
- Installation of Play Equipment not complete, resulting in return trip
- Poor Site Access not identified in Proposal or Project Scope
- Customer requirement/request for work on weekends, holidays, or overtime
- Any and all scope variations not agreed upon in writing
- Security that was not included in the base quote
- Waste Removal that was not included in the base quote

Wet Site Conditions: installation areas located near wetlands, where a high water table exists or in any environment that produces excessive moisture will require additional planning prior to installation of your project. Unless excessively wet conditions have been conveyed prior to installation quote and accounted for in some manner, your installation will not proceed. Ideal dry conditions need to be present to begin, and complete, your project as quoted.

Exclusions: unless specifically included, this quotation excludes all site work and landscaping; removal of existing equipment; acceptance of equipment and off-loading; storage of goods prior to installation; equipment assembly and installation; safety surfacing; borders and drainage provisions.



MWP Recreation
4800 Olson Memorial Hwy, Suite 130 Golden Valley, Minnesota 55422
Ph. 800-622-5425 | 763-546-778 | dan@MWPprecreation.com

12/08/2025
Quote #
106743-01-05

CONSULTANT: DAN LANES

RFP Sunnyside Park - Option 2 - Rogers, MN - D12925L - M

Order Information:

Bill To: _____ Ship To: _____

Company: _____ Project Name: _____

Attn: _____ Attn: _____

Address: _____ Address: _____

City, State, Zip: _____ City, State, Zip: _____

Contact: _____ Contact: _____

Tel: _____ Tel: _____

Fax: _____ Fax: _____

Email: _____ Email: _____

Acceptance of quotation:

Accepted By (printed): _____ P.O. No: _____

Signature: _____ Date: _____

Title: _____ Phone: _____

Facsimile: _____ Purchase Amount: **\$248,045.91**



St. Croix Recreation Fun Playgrounds INC.
 1826 Tower Dr W
 Stillwater, MN 55082-7597 USA
 6514301247
 hannah@stcroixrec.com



Estimate

ESTIMATE # 8017

DATE 12/08/2025

EXPIRATION DATE 01/30/2026

ADDRESS

CITY OF ROGERS
 Accounts Payable
 22350 South Diamond Lake
 Road
 Rogers, Minnesota 55374

SHIP TO

CITY OF ROGERS
 ATTN: MIKE BAUER,
 DIRECTOR OF PARKS
 AND RECREATION
 SUNNYSIDE PARK
 RENOVATION
 Rogers, Minnesota 55374

PLEASE DETACH TOP PORTION AND RETURN WITH YOUR PAYMENT.

SHIP VIA
 TRUCKLOAD

ACTIVITY	QTY	RATE	AMOUNT
Services CUSTOM BURKE PLAYGROUND AS DESCRIBED, LISTED AND DEPICTED IN ATTACHED PROPOSAL #100-210752-1	1	180,710.00	180,710.00
SAFEFALL SAFEFALL PIP RUBBER RESILIENT SURFACING FOR REQUIRED CRITICAL FALL HEIGHTS PER PROJECT SPECIFICATION: 50% COLOR/50% BLACK LARGE GRAPHIC FORMS. NOTE: 3000 S.F. ALLOWANCE. ALLOCATION NOT NECESSARILY FULLY DEPICTED IN ATTACHED IMAGES BUT WILL PROVIDE ALL NECESSARY ACCESS TO THE REQUIRED ACTIVITIES EXCEEDING ADAAG REQUIREMENTS. INCLUDES REQUIRED BASE MATERIALS.	3,000	24.25	72,750.00
EWf - Blown-in Wood Fiber quote includes freight and material blown-in by hose/blower truck of quoted CY to the site listed on the estimate by a 300' hose. Quoted CY amount based on customer information provided. If you are unsure of the quantity of CY needed, please provide SQFT and depth. Desired depth should be appropriate for equipment safety standards. It is the customer's responsibility to ensure that the drop site is accessible by truck and that a 300' hose will reach all areas of the site. If additional length is needed, please alert us. Site work and restoration for pre/post project is not included.	260	46.00	11,960.00
INSTALL INSTALLATION OF EQUIPMENT. INSTALLATION WILL BE COMPLETED BY FACTORY CERTIFIED CONTRACTOR. INSTLLATION CONTRACTOR WILL DIRECTY INVOICE THE CITY FOR INSTALLATION.	1	40,000.00	40,000.00
Freight Freight quotes currently only valid for 15 days. Quote based on information currently listed on estimate. Modifications to delivery address, contact or offloading capability must be made prior to order. If made after order is placed, surcharges may apply.	1	6,500.00	6,500.00
APPLIED DISCOUNT ADDITIONAL MFG. DISCOUNT APPLIED	1	-12,650.00	-12,650.00

By signing estimate or authorizing by email or PO, purchaser is agreeing to billing terms as listed on the estimate. Order to include model number(s), quantity and color(s) above including any supplemental documents provided and/or requested. Please verify all content for accuracy. **Those purchasing off of the MN State Contract are bound only by the terms and conditions listed in said contract**

MATERIAL ITEMS AS QUOTED ARE GOOD FOR 30 DAYS. FREIGHT QUOTES ARE GOOD FOR 15 DUE TO FUEL UNCERTAINTIES. SALES TAX SUBJECT TO CHANGE. ADD IF NOT TAX EXEMPT OR SUPPLY EXEMPTION CERTIFICATE IF NOT ON FILE. PAYMENT TERMS ARE NET 30 DAYS UNLESS OTHERWISE NOTED. FAILURE TO PAY IN A TIMELY MANNER WILL BE SUBJECT TO INTEREST AT A RATE OF 1.5%/MONTH OR 18% ANNUALLY.

SUBTOTAL	299,270.00
TAX (8.775%)	0.00
TOTAL	\$299,270.00

*LEAD TIMES AND SHIPPING DATES ARE BASED ON CURRENT INVENTORY. PLEASE BE PATIENT AS OUR VENDORS NAVIGATE SUPPLY CHAINS & NATIONAL SHORTAGES.

**FOR BIDDING CONTRACTORS & SUPPLIERS: ST CROIX RECREATION IS NOT LIABLE FOR INTERPRETATION OF PROJECT BIDS, DRAWINGS OR ADDENDA. IT IS THE CUSTOMER'S RESPONSIBILITY TO VERIFY ACCURACY OF MODEL NUMBER(S), DESCRIPTION(S), QUANTITY AND COLOR(S) DIRECTLY WITH END USER

Accepted By

Accepted Date

By signing estimate or authorizing by email or PO, purchaser is agreeing to billing terms as listed on the estimate. Order to include model number(s), quantity and color(s) above including any supplemental documents provided and/or requested. Please verify all content for accuracy. **Those purchasing off of the MN State Contract are bound only by the terms and conditions listed in said contract**

NOTE: Sandbox is not correctly depicted. No cement curb will be present inside the container. PIP rubber surface will form the interior containment for the sand. In addition the Playhouse will be 75% accessible with PIP surfacing allowing interactive creative play utilizing sand materials to foster imaginative play and maximizing inclusive play.



COLOR KEY

- NAVY
- SILVER
- ORANGE
- YELLOW
- OCEAN
- LIME
- ORANGE/BLACK
- YELLOW/BLACK
- OCEAN/BLACK
- LIME/BLACK



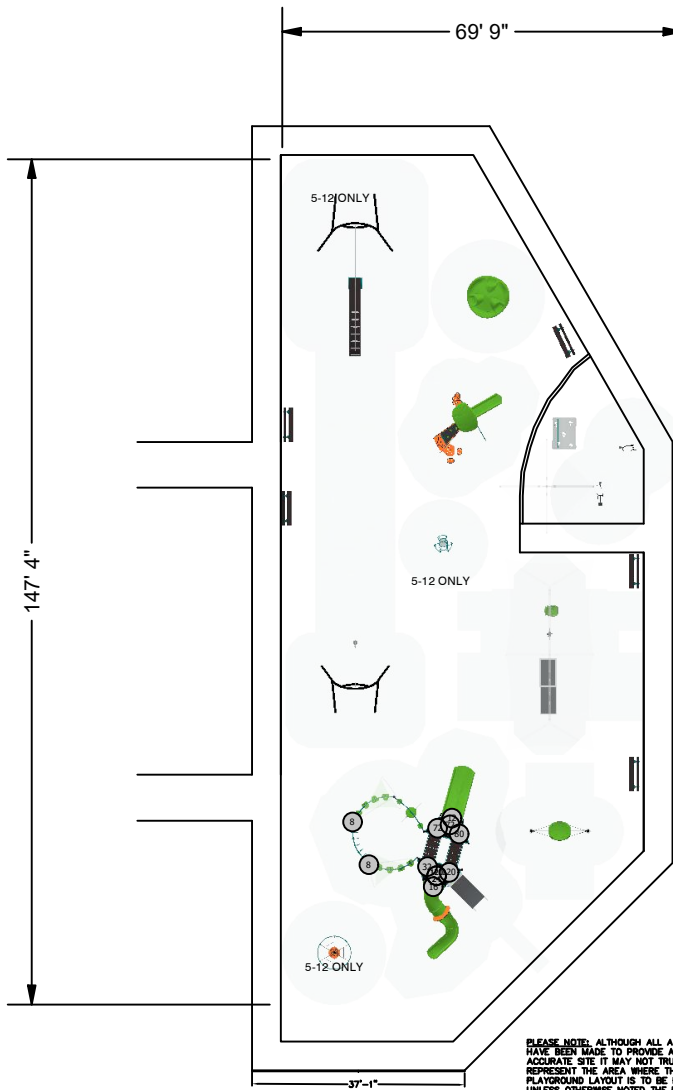

PLEASE NOTE, ALTHOUGH ALL ATTEMPTS HAVE BEEN MADE TO PROVIDE AN ACCURATE SITE IT MAY NOT TRULY REPRESENT THE AREA WHERE THIS PLAYGROUND LAYOUT IS TO BE PLACED. UNLESS OTHERWISE NOTED THE PLAY AREA IS ASSUMED TO BE LEVEL.

Sunnyside Park City of Rogers, MN

SERIES Burke Basics | Nucleus | Intensity | ShadePlay Max

GROUP: 5-12 Structure | Freestanding

DESIGNED FOR AGES: 5 to 12, 2 to 12

SITE PLAN VIEW

Sunnyside Park
Rogers, MN 55374

Burke
PLAY THAT MOVES YOU

St. Croix Recreation Fun Playgrounds
100-216752-1

Designer: Brittany Murphy

11/26/2025

BCI BURKE COMPANY, LLC | PO BOX 549 FOND DU LAC, WI 54936-0549 | 920.921.9220 | BCI@BURKE.COM

OVERALL BOUNDING OF USE ZONES **The space requirements shown here are to ASTM standards. Requirements for other standards may be different.

Area: 10261.8 sq.ft.
Perimeter: 433.9 ft.
STRUCTURE SIZE 7' 4" x 69' 9"
POST SIZE(S)

PLAYGROUND ACCESSIBILITY (Provided/Required)					
TOTAL EVENTS	ELEVATED EVENTS	TRANSFER ACCESSIBLE EVENTS	RAMP ACCESSIBLE EVENTS	GROUND EVENTS	TYPES OF GROUND EVENTS
27	8 / 4	8 / 0	0 / 0	17 / 3	9 / 3

The use and layout of play components identified in this plan conform to the CPSC guidelines. U.S. CPSC recommends the separation of age groups in playground layouts.

Warning: Accessible safety surfacing material is required beneath and around this equipment that is compliant with ASTM, CPSC, and ADAAG requirements.

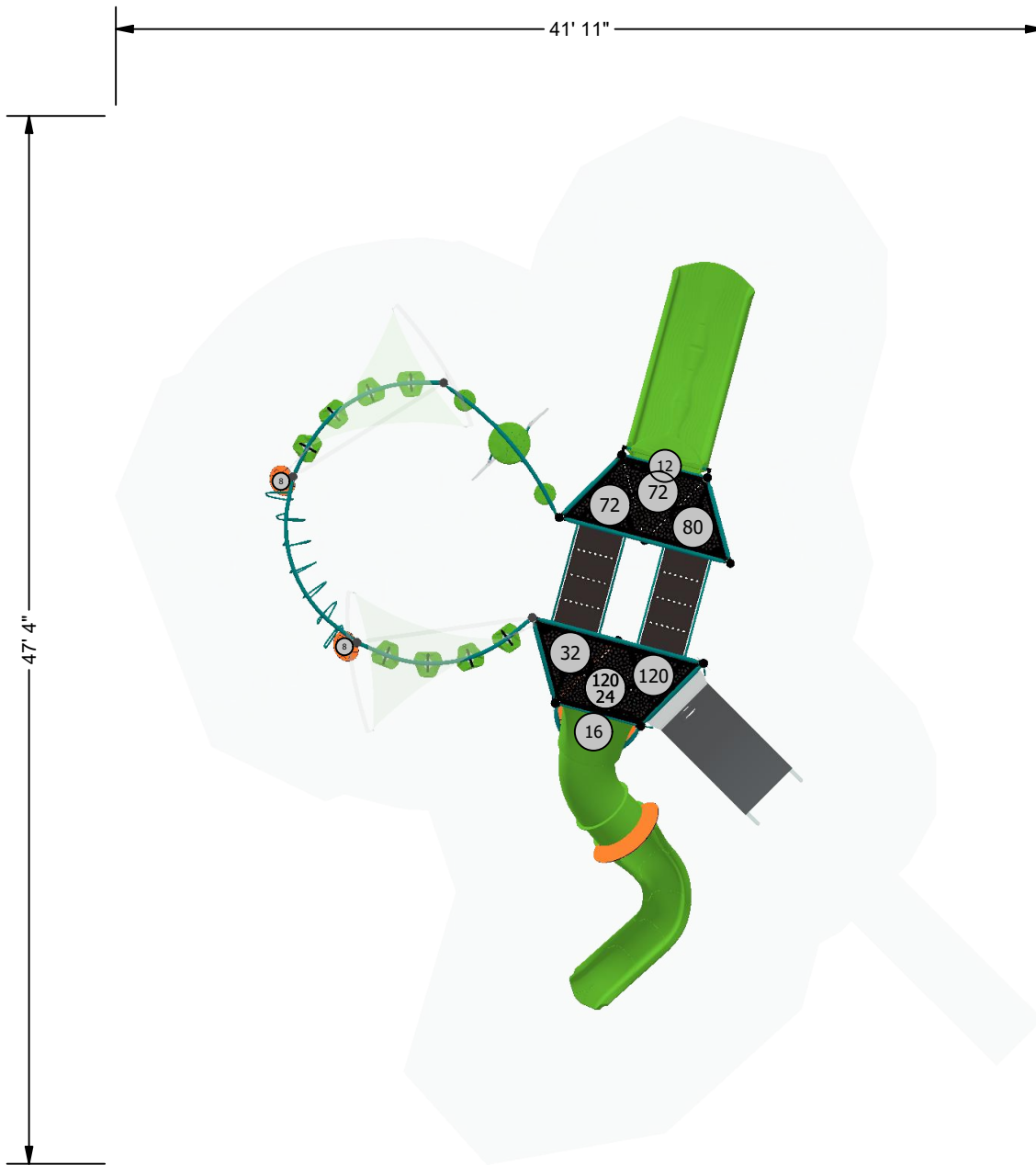

SERIES Nucleus | Intensity | Burke Basics

GROUP:
5-12 Structure

DESIGNED FOR AGES:
5 to 12

SITE PLAN VIEW

Sunnyside Park
Rogers, MN 55374

Burke
PLAY THAT MOVES YOU

St. Croix Recreation Fun Playgrounds

100-216752-1

Designer: Brittany Murphy

11/26/2025

BCI BURKE COMPANY, LLC | PO BOX 549 FOND DU LAC, WI 54936-0549 | 920.921.9220 | BCI@BURKE.COM

OVERALL BOUNDING OF USE ZONES

Area: 10261.8 sq.ft.
Perimeter: 433.9 ft.
STRUCTURE SIZE 7' 4"x69' 9"
POST SIZE(S)

**The space requirements shown here are to ASTM standards. Requirements for other standards may be different.

PLAYGROUND ACCESSIBILITY (Provided/Required)

TOTAL EVENTS	ELEVATED EVENTS	TRANSFER ACCESSIBLE EVENTS	RAMP ACCESSIBLE EVENTS	GROUND EVENTS	TYPES OF GROUND EVENTS
27	8 / 4	8 / 0	0 / 0	17 / 3	9 / 3

The use and layout of play components identified in this plan conform to the CPSC guidelines. U.S. CPSC recommends the separation of age groups in playground layouts.

Warning: Accessible safety surfacing material is required beneath and around this equipment that is compliant with ASTM, CPSC, and ADAAG requirements.

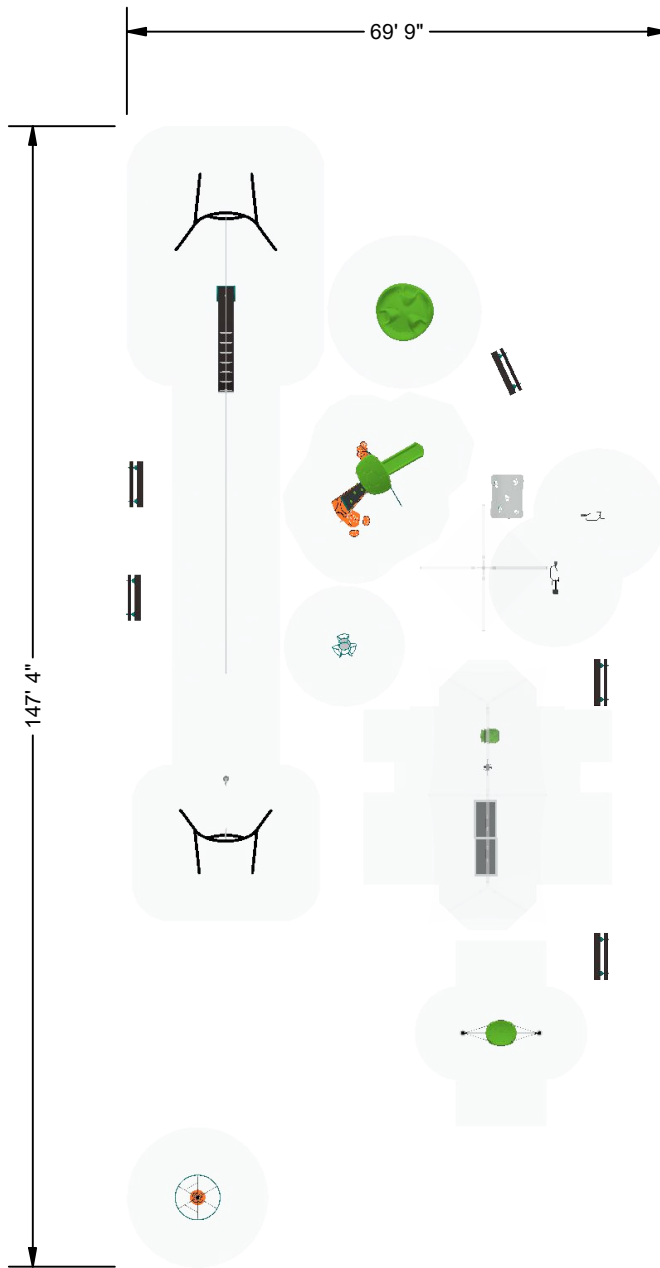

SERIES Burke Basics | ShadePlay Max

SITE PLAN VIEW

GROUP:
Freestanding
DESIGNED FOR AGES:
2 to 12

Sunnyside Park
Rogers, MN 55374

11/26/2025

Burke
PLAY THAT MOVES YOU

St. Croix Recreation Fun Playgrounds
100-216752-1

Designer: Brittany Murphy

BCI BURKE COMPANY, LLC | PO BOX 549 FOND DU LAC, WI 54936-0549 | 920.921.9220 | BCI@BURKE.COM

OVERALL BOUNDING OF USE ZONES

Area: 10261.8 sq.ft.
Perimeter: 433.9 ft.
STRUCTURE SIZE 7' 4"x69' 9"
POST SIZE(S)

**The space requirements shown here are to ASTM standards. Requirements for other standards may be different.

PLAYGROUND ACCESSIBILITY (Provided/Required)

TOTAL EVENTS	ELEVATED EVENTS	TRANSFER ACCESSIBLE EVENTS	RAMP ACCESSIBLE EVENTS	GROUND EVENTS	TYPES OF GROUND EVENTS
27	8 / 4	8 / 0	0 / 0	17 / 3	9 / 3

The use and layout of play components identified in this plan conform to the CPSC guidelines. U.S. CPSC recommends the separation of age groups in playground layouts.

Warning: Accessible safety surfacing material is required beneath and around this equipment that is compliant with ASTM, CPSC, and ADAAG requirements.

ITEM	COMP.	DESCRIPTION
1	270-0129	TRIANGLE PLATFORM
2	370-0223	PURSUIT CLIMBER 16"-40"
3	470-0752	ARA POLY SHADE CANOPY
4	370-1675	STRAIGHT OVERHEAD, NUCLEUS
5	370-1718	TAKTIKS BOW CLIMBER
6	370-1608	OVISTEP LAUNCH PAD
7	370-0041	EVOLUTION 40" TRANSITION STAIR W/ BARRIERS
8	470-0128	FLYLOW POD
9	470-0977	EVOLUTION HALF HEX ROOF
10	470-0008	EVOLUTION SIDE ROOF SUPPORT, LEFT
11	470-0006	EVOLUTION BOTTOM ROOF SUPPORT, SINGLE
12	470-0009	EVOLUTION SIDE ROOF SUPPORT, RIGHT
13	570-2713	HIDE THE NUMBERS PANEL
14	470-0788	COBRA SLIDE FUSION "S" RIGHT 120"
15	370-0224	VICTORY CLIMBER
16	370-1666	SHASTA CLIMBER, 80"-96"
17	270-0122	EVOLUTION OFFSET ENCLOSURE
18	270-0009	8" CLOSURE PLATE, ELLIPSE
19	470-0803	CONTOUR SLIDE, 64"-72"
20	370-0865	TREE BRANCH CLIMBER 72"
21	270-0120	EVOLUTION UNITARY ENCLOSURE
22	470-0075	CRESCENT PLATFORM
23	560-2707	EKO DUAL

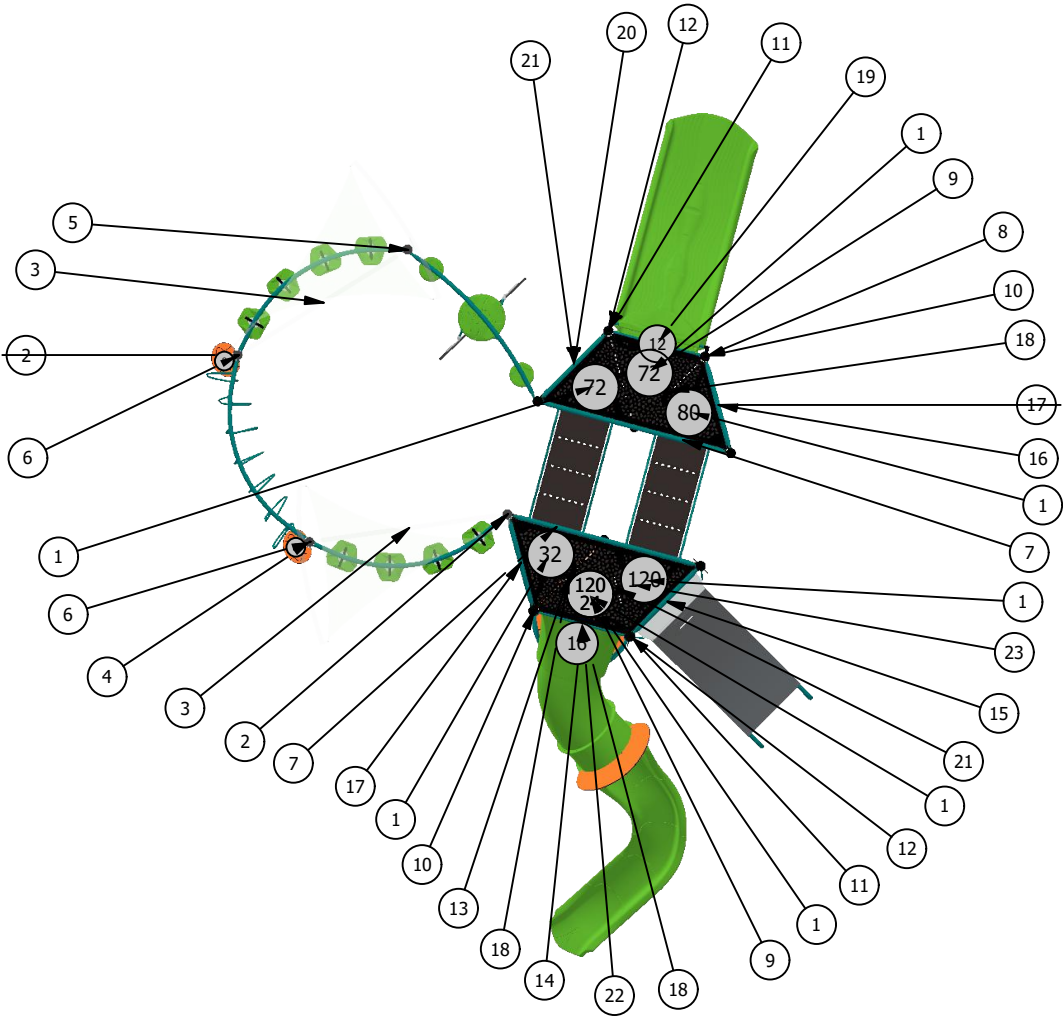

SERIES Nucleus | Intensity | Burke Basics

GROUP:
5-12 Structure

DESIGNED FOR AGES:
5 to 12

COMPONENT VIEW

Sunnyside Park
Rogers, MN 55374

Burke
PLAY THAT MOVES YOU

St. Croix Recreation Fun Playgrounds
100-210752-1

Designer: Brittany Murphy

11/26/2025

BCI BURKE COMPANY, LLC | PO BOX 549 FOND DU LAC, WI 54936-0549 | 920.921.9220 | BCIBURKE.COM

ITEM	COMP.	DESCRIPTION
1	590-0063	LITTLE DIGGER ADA
2	590-0064	LITTLE DIGGER
3	560-2589	COMET II
4	560-2579	VOLTA INCLUSIVE SPINNER
5	560-2765	VOLTA SPINNER FOOTER
6	580-1424	CASTRA PLAYFORT
7	046-0536	PLAYMAT 3' X 5' X 2"
8	580-0190	6' PVC TRADITIONAL BENCH W/BACK SM
9	550-0206	ZIPVENTURE
10	550-0210	SHADEPLAY MAX DOUBLE BAY SWING CANOPY 15' X 33'
11	550-0111	BELT SEAT, 8' SINGLE, STD CHAIN
12	550-0099	TOT SEAT, 7' & 8' SINGLE, STD CHAIN
13	550-0171	FREEDOM SWING SEAT, 8' BEAM, STD CHAIN
14	580-1373	PLAYHOUSE
15	560-2610	SPINETIC W/ SPEED LIMITER
16	550-0226	CIRRUS DUO POST SWING,VERTICAL
17	560-2729	16' X 16' X 10' SHADEPLAY MAX HYPAR SHADE

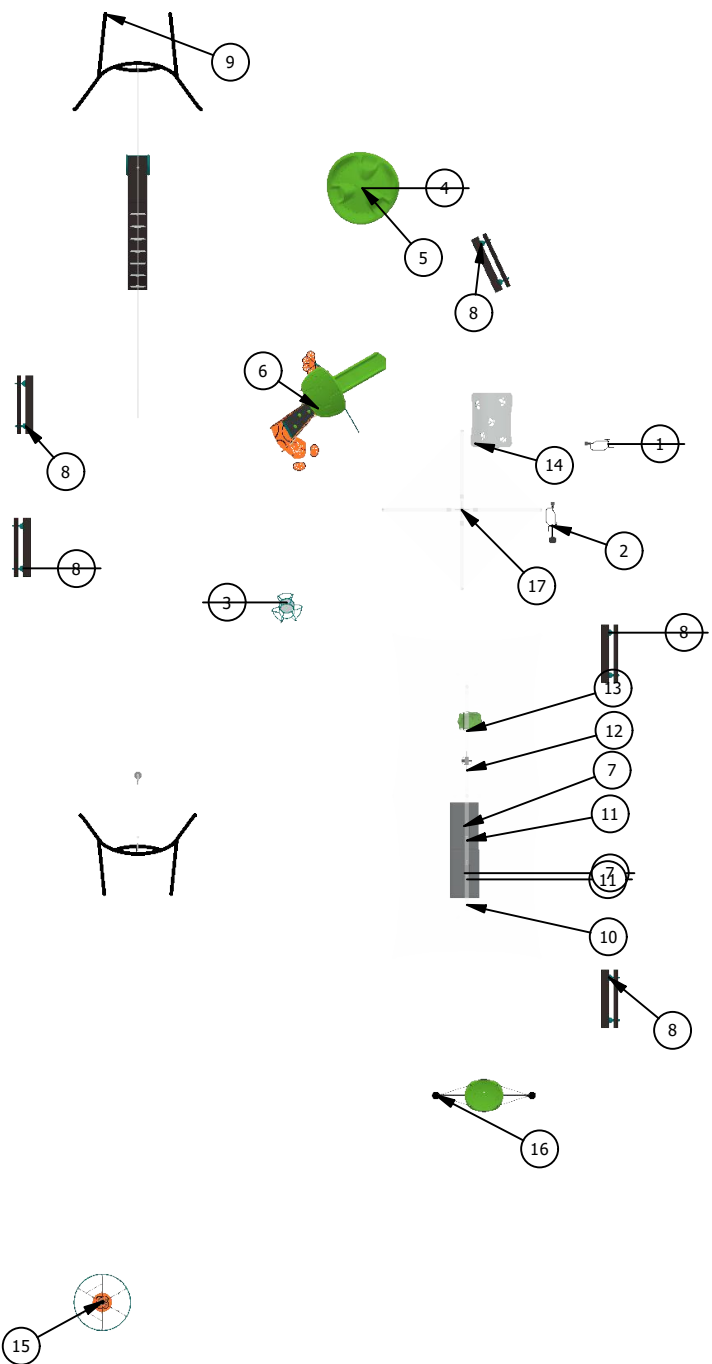

SERIES Burke Basics | ShadePlay Max

COMPONENT VIEW

GROUP:
Freestanding
DESIGNED FOR AGES:
2 to 12

Sunnyside Park
Rogers, MN 55374
Burke
PLAY THAT MOVES YOU

11/26/2025
St. Croix Recreation Fun Playgrounds
100-210752-1
Designer: Brittany Murphy

BCI BURKE COMPANY, LLC | PO BOX 549 FOND DU LAC, WI 54936-0549 | 920.921.9220 | BCIBURKE.COM

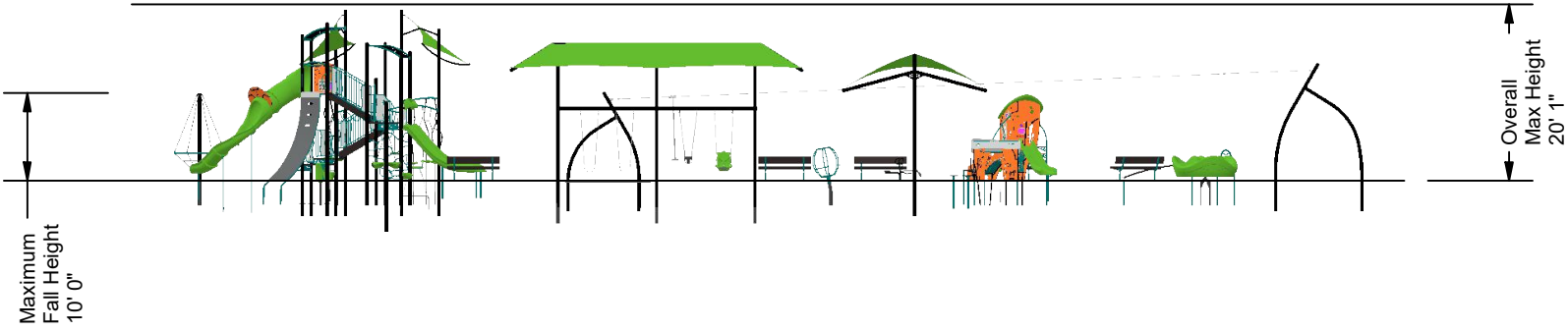

SERIES Burke Basics | Nucleus | Intensity | ShadePlay Max

ELEVATION VIEW

GROUP:
5-12 Structure/Freestanding

DESIGNED FOR AGES:
5 to 12, 2 to 12

Sunnyside Park
Rogers, MN 55374

Burke
PLAY THAT MOVES YOU

St. Croix Recreation Fun Playgrounds
100-216752-1

Designer: Brittany Murphy

11/26/2025

BCI BURKE COMPANY, LLC | PO BOX 549 FOND DU LAC, WI 54936-0549 | 920.921.9220 | BCIBURKE.COM

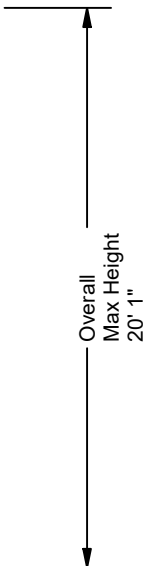

SERIES Nucleus | Intensity | Burke Basics

ELEVATION VIEW

GROUP:
5-12 Structure
DESIGNED FOR AGES:
5 to 12

Sunnyside Park
Rogers, MN 55374

Burke
PLAY THAT MOVES YOU[®]

11/26/2025
St. Croix Recreation Fun Playgrounds
100-210752-1
Designer: Brittany Murphy

BCI BURKE COMPANY, LLC | PO BOX 549 FOND DU LAC, WI 54936-0549 | 920.921.9220 | BCIBURKE.COM

Overall
Max Height
15' 8"

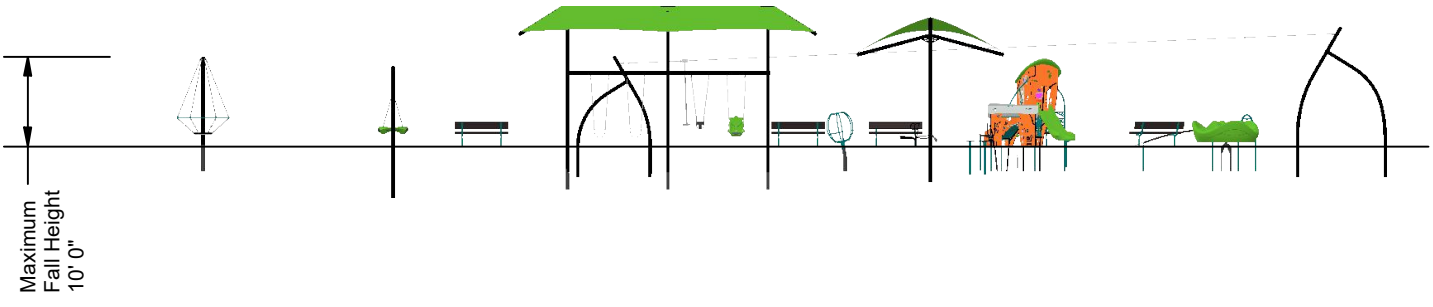

SERIES Burke Basics | ShadePlay Max

GROUP:
Freestanding
DESIGNED FOR AGES:
2 to 12

Sunnyside Park
Rogers, MN 55374



St. Croix Recreation Fun Playgrounds

11/26/2025
100-210752-1
Designer: Brittany Murphy

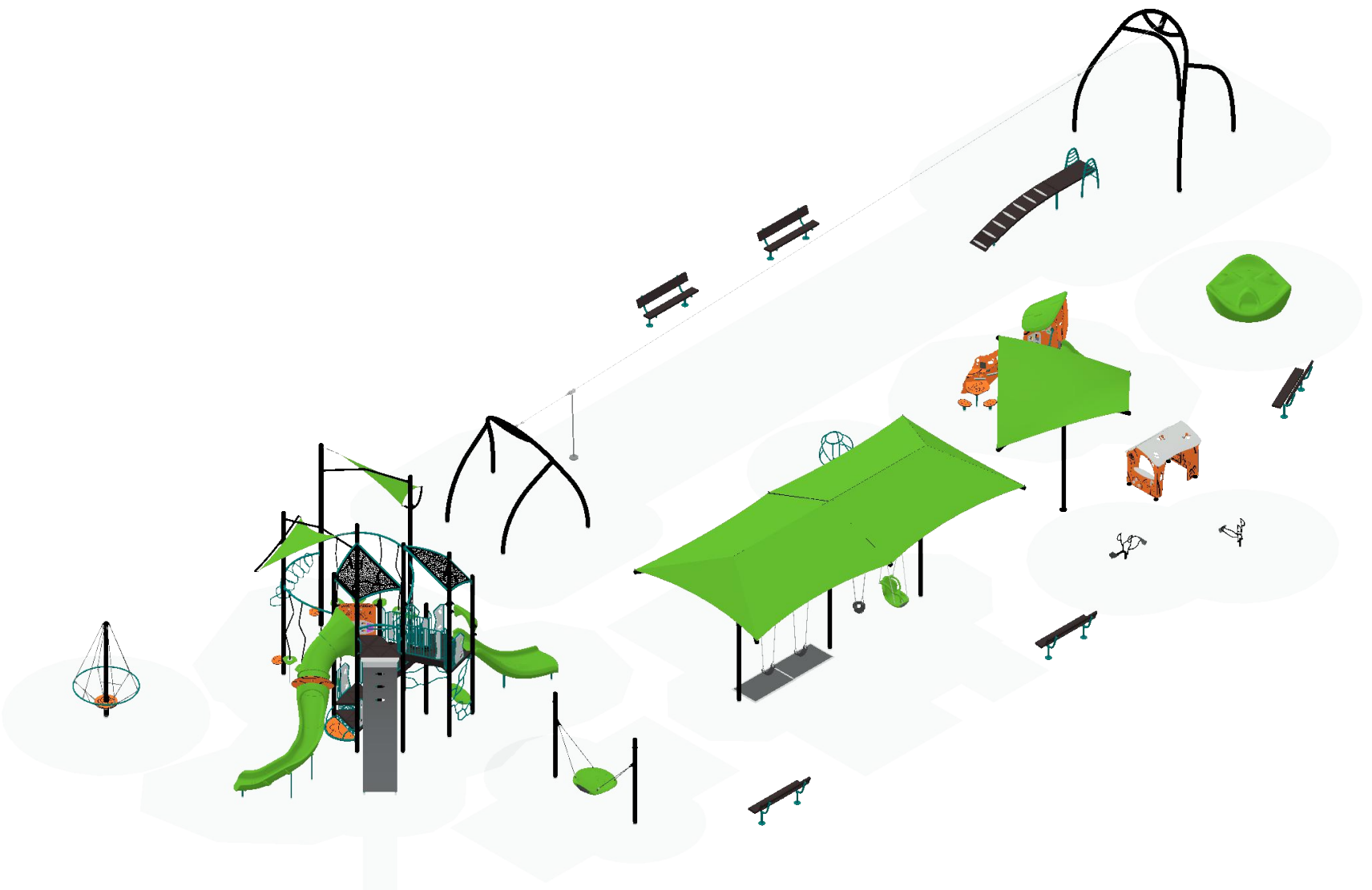

SERIES Burke Basics | Nucleus | Intensity | ShadePlay Max

ISOMETRIC VIEW

GROUP:
5-12 Structure/Freestanding

DESIGNED FOR AGES:
5 to 12, 2 to 12

Sunnyside Park
Rogers, MN 55374

Burke
PLAY THAT MOVES YOU

St. Croix Recreation Fun Playgrounds
100-210752-1

Designer: Brittany Murphy

11/26/2025



SERIES Nucleus | Intensity | Burke Basics

ISOMETRIC VIEW

GROUP:
5-12 Structure
DESIGNED FOR AGES:
5 to 12

Sunnyside Park
Rogers, MN 55374

Burke
PLAY THAT MOVES YOU

11/26/2025

St. Croix Recreation Fun Playgrounds
100-210752-1

Designer: Brittany Murphy

BCI BURKE COMPANY, LLC | PO BOX 549 FOND DU LAC, WI 54936-0549 | 920.921.9220 | BCIBURKE.COM



SERIES Burke Basics | ShadePlay Max

ISOMETRIC VIEW

GROUP:
Freestanding
DESIGNED FOR AGES:
2 to 12

Sunnyside Park
Rogers, MN 55374

Burke
PLAY THAT MOVES YOU

St. Croix Recreation Fun Playgrounds
100-210752-1

Designer: Brittany Murphy

11/26/2025

BCI BURKE COMPANY, LLC | PO BOX 549 FOND DU LAC, WI 54936-0549 | 920.921.9220 | BCI.BURKE.COM



STAFF REPORT

ROGERS PARKS AND RECREATION ADVISORY COMMISSION

Meeting Date: December 11, 2025

Agenda Item: 6.5

Subject: Consider the updated plan for Crow River Heights Park

Prepared By: Mike Bauer, Parks & Recreation Director

Overview / Background / Analysis

Crow River Heights Park Playground was identified for replacement following a community outreach process conducted in 2023. Through that outreach, residents expressed interest in maintaining a playground that serves neighborhood-scale needs while improving play variety, safety, and overall durability. The outreach results were used to guide the development of the attached preliminary design concept.

At the time the initial design direction was developed, the project was anticipated to be largely completed in-house. However, several key staff transitions over the past year have changed the City's capacity to deliver the project internally. To support timely delivery, consistent quality, and reduced construction risk, staff is now recommending the project proceed as a more turnkey installation through a certified playground manufacturer and installer.

Proposed Playground Design

The attached preliminary concept has been prepared by Flagship Recreation using the Landscape Structures system and reflects a similar playground "container" footprint to what currently exists at Crow River Heights. The approach focuses on replacing aging equipment while retaining the overall scale and neighborhood character of the play area.

A concept site plan showing the playground layout and its relationship to existing park features, trails, and the Crown River overlook area is included with the materials .

Budget Overview

A preliminary project budget estimate has been provided by Flagship Recreation under the State Cooperative Contract for playground equipment. This estimate reflects a turnkey delivery including materials, professional installation, and surfacing.

Key budget components include:

- **Play equipment (state contract pricing):** \$45,085

- **State contract discount (6%):** -\$2,705
- **Delivery:** \$600
- **Mobilization:** \$750
- **Dumpsters/Disposal:** \$750
- **Plastic timber border and ramp:** \$5,628
- **Professional equipment installation (labor and concrete footings):** \$12,366
- **Engineered wood fiber surfacing (118 cubic yards):** \$5,310
- **EWF freight:** \$800
- **Rubber wear mats:** \$786

Preliminary Total Project Estimate: \$69,370

This figure does not include potential concrete or asphalt connections to the playground entrance or site restoration outside the equipment container, which would be addressed separately if pursued as part of the larger park improvements. The budget provided is preliminary and not a formal contract quote.

Staff Recommendation

Financial Impact:

Source Fund:

Budgeted? Yes

Supporting Documentation

- A. Crow River Heights 2017 Plan
- B. 17586_CROW RIVER SITE PLAN
- C. Preliminary Design & Budget_CrowRiverHeights Opt 1 -12-10-25
- D. Preliminary Design & Budget_CrowRiverHeights Opt 2_12-10-25



CROW RIVER HEIGHTS PARK



CLASSIFICATION
Neighborhood Park

SIZE
1.1 acres

PROPOSED IMPROVEMENTS

- ✓ Remove sand volleyball court
- ✓ Provide 4-6 stall parking lot (in sand volleyball location)
- ✓ Incorporate an accessible watercraft access and fishing platform along Crow River (Will require DNR approval), including an accessible walkway connection from the proposed parking lot, wayfinding signage, and picnic areas.
- ✓ Provide an accessible walkway connection from the proposed parking lot to the existing play container
- ✓ Provide a portable restroom on a concrete pad
- ✓ Consider reconfiguring the existing play container when the plans for the proposed parking lot are developed and implement the play container changes when the play equipment needs to be replaced
- ✓ Continue to protect and manage the existing natural resources within the park and open space

LEGEND

-  PARK BOUNDARY
-  850 INDEX CONTOUR
-  851 INTERMEDIATE CONTOUR

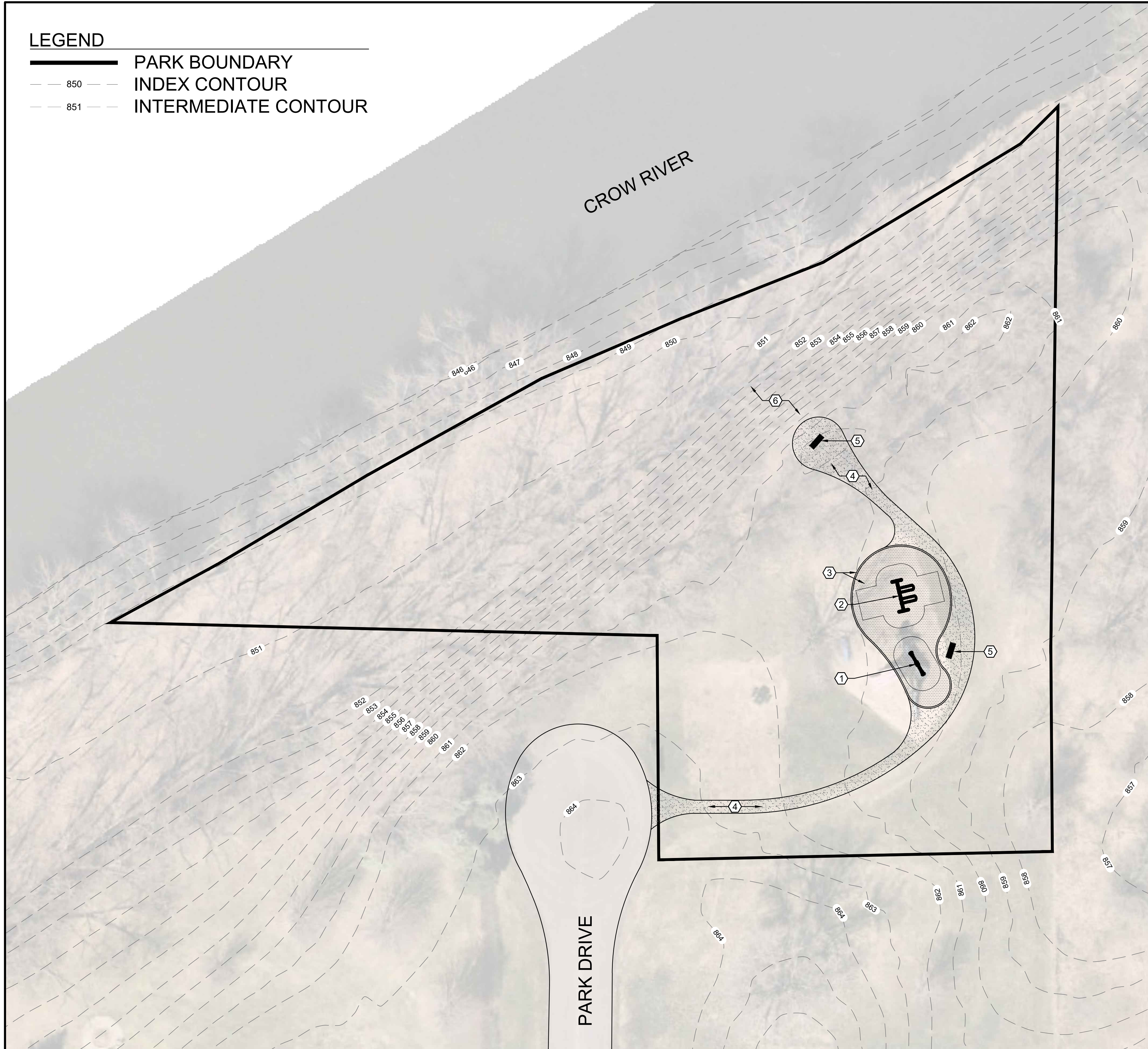

① SEESAW



② STANDARD ARCH SWINGS, 2 SEATS



③ CONCRETE CURB BORDER AND ENGINEERED WOOD FIBER FALL MATERIAL

④ GRAVEL TRAIL

⑤ PARK BENCH

⑥ SCENIC RIVER OVERLOOK
- SELECTIVE TREE REMOVALS FOR VIEWS TO RIVER



13605 1st Avenue N. #100
Plymouth, MN 55441 | ae-mn.com
P 763.412.4000 | F 763.412.4090
Anderson Engineering of Minnesota, LLC

CROW RIVER HEIGHTS PARK IMPROVEMENTS

15150 PARK DRIVE

CITY OF ROGERS

REVISION LOG

NO.	DATE	DESCRIPTION OF REVISIONS

CONCEPT DESIGN

01/31/2024

DESIGNED: JDL	DRAWN: JRS	CHECKED BY: JDL
------------------	---------------	--------------------

DRAWING TITLE

CONCEPT SITE PLAN

DRAWING NO.

C1

PLOTTED:

COMM. NO.
17587

Jan 17, 2024 - 1:47pm jschmitzlerle
 Y:\17500\17586 CITY OF ROGERS CROW RIVER HEIGHTS PARK_06 LA_01 CAD files_02 xRefs\17586_c_base.dwg
 Xref Filename: \17587_titleblock

C:\Users\Amanda\OneDrive\Flagship Recreation\Documents\2026 Planning\Brett\Design\Crow River Height\Design\Plan_CrowRiverHeight_Opt 1 - 11215.dwg

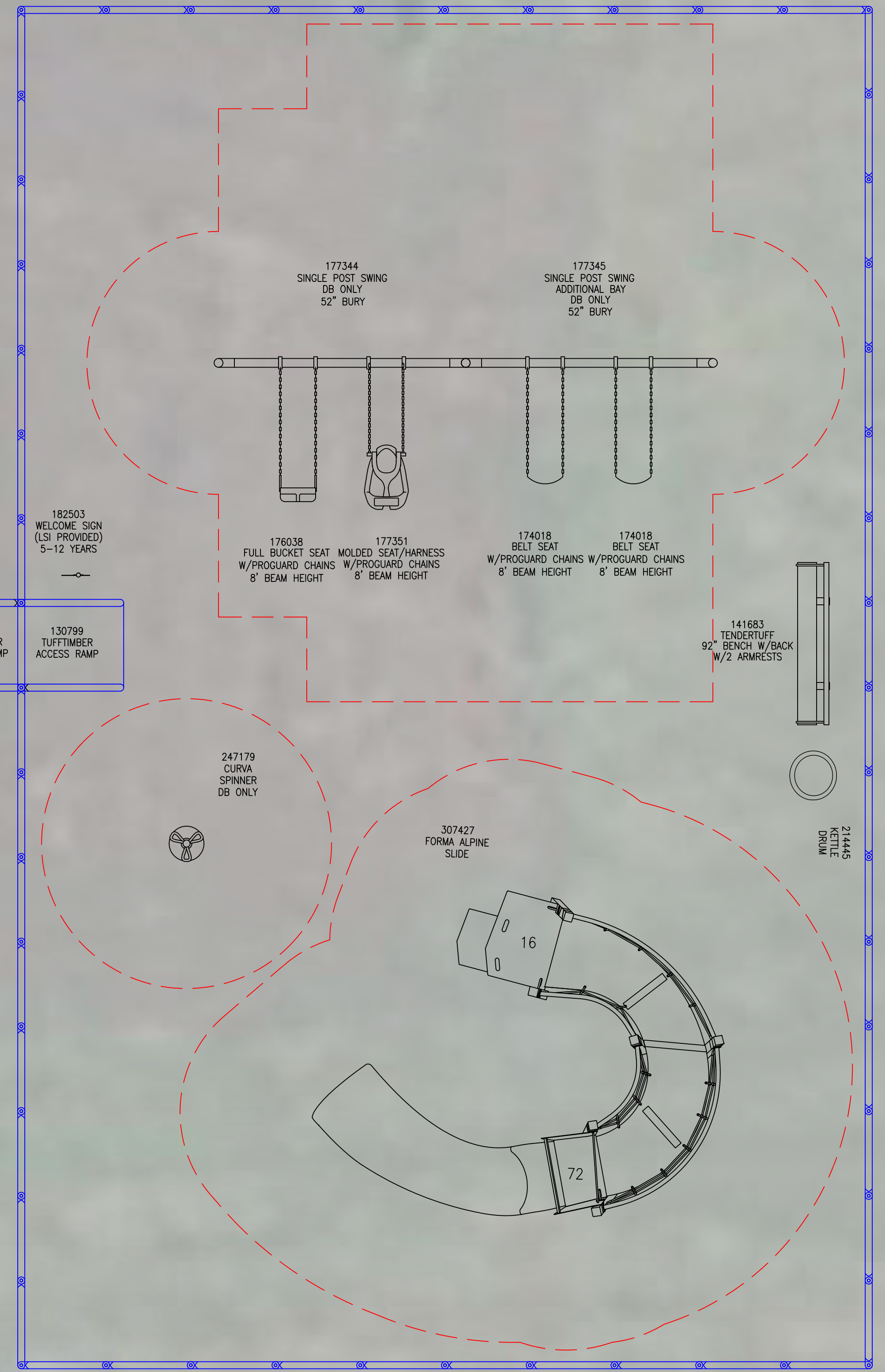
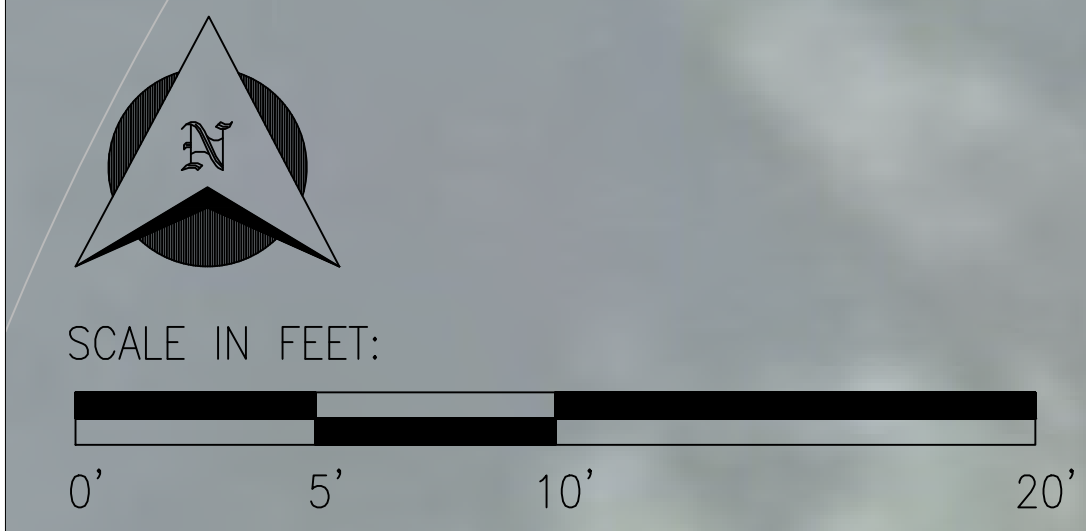

Forma
(5-12 years)
Max Fall Height: 96 inches

ADA CONNECTION TO PLAYGROUND BY OWNER

CONTAINER DETAILS

TOTAL CONTAINER AREA	2560 SF
ASTM SAFETY SURFACING TYPE	ENGINEERED WOOD FIBER
TOTAL EWF AREA	2560 SF
TOTAL PERIMETER	208 LF
EDGING TYPE	4' PLASTIC TIMBERS
FINISH GRADE	TOP OF CURB

- **SITE PREPARATION REQUIREMENTS:**
- MAXIMUM OF 1% GRADE CHANGE ACROSS CONTAINER
 - NO PRE-INSTALLED DRAIN TILE OUTSIDE OF 4 FEET OF PERIMETER
 - DRAIN TILE STUB TO BE PROVIDED IF DRAIN TILE IS REQUIRED
 - NO DRAINAGE AGGREGATE PRE-INSTALLED
 - NO FABRIC PRE-INSTALLED
 - MINIMUM CONTAINER SIZE NEEDED DENOTES THE INSIDE OF CURB DIMENSION

5-12 AREA

TOTAL ELEVATED PLAY COMPONENTS	2		
TOTAL ELEVATED COMPONENTS ACCESSIBLE BY RAMP	0	REQUIRED	0
TOTAL ELEVATED COMPONENTS ACCESSIBLE BY TRANSFER	2	REQUIRED	1
TOTAL ACCESSIBLE GROUND LEVEL COMPONENTS SHOWN	5	REQUIRED	1
TOTAL DIFFERENT TYPES OF GROUND LEVEL COMPONENTS	3	REQUIRED	3



FLAGSHIP RECREATION
11123 UPPER 33RD ST N
LAKE ELMO, MN 55082
763-550-7860
FLAGSHIPPLAY.COM
@FLAGSHIPPLAY



THIS PLAY AREA & PLAY EQUIPMENT IS DESIGNED FOR AGE RANGES AS NOTED ON PLAN.

CROW RIVER HEIGHTS
PLAYGROUND
OPTION 1

15150 PARK DR,
DAYTON, MN 55327

SALES REPRESENTATIVE:
BRETT ALTERGOTT

DESIGNED BY:
AO
11/21/25

1/4" = 1'-0"

SHEET
LS101





LS landscape
structures

Crow River Heights - Option 1

Roger_CrowRiverHeights Opt 1 - 112125 • 11.21.2025



© 2025 Landscape Structures. All Rights Reserved



 **landscape structures**

Crow River Heights - Option 1



Roger_CrowRiverHeights Opt 1 - 112125 • 11.21.2025

 **flagship**
recreation

© 2025 Landscape Structures. All Rights Reserved





 Crow River Heights - Option 1
Roger_CrowRiverHeights Opt 1 - 112125 • 11.21.2025 

© 2025 Landscape Structures. All Rights Reserved



 **landscape structures**

Crow River Heights - Option 1

Roger_CrowRiverHeights Opt 1 - 112125 • 11.21.2025

 **flagship**
recreation

© 2025 Landscape Structures. All Rights Reserved

State Contract #218091



PROJECT INFORMATION

Crow River Heights Park

15150 Park Dr,

Dayton, MN 55327

Contract Year: 2026

EQUIPMENT INFORMATION & PRICING

<u>Qty</u>	<u>Item No.</u>	<u>Description</u>	<u>Price</u>	<u>Ext Price</u>
1	307427A	Forma Alpine Slide DB	\$32,676	\$32,676.00
1	141683Q	92" TenderTuff Bench w/Back Two Armrests DB	\$1,239	\$1,239.00
2	174018A	Belt Seat ProGuard Chains for 8' Beam Height	\$179	\$358.00
1	176038A	Full Bucket Seat ProGuard Chains for 8' Beam Height	\$500	\$500.00
1	177344A	Single Post Swing Frame 52" Bury 8' Beam Height Only DB Only	\$1,938	\$1,938.00
1	177345A	Single Post Swing Frame 52" Bury Additional Bay 8' Beam Height Only DB Only	\$1,382	\$1,382.00
1	177351A	Molded Bucket Seat (5-12 yrs) w/Harness ProGuard Chains for 8' Beam Height	\$1,219	\$1,219.00
1	182503C	Welcome Sign (LSI Provided) Ages 5-12 years Direct Bury	\$0	\$0.00
1	214445A	Rhapsody Kettle Drum DB	\$2,101	\$2,101.00
1	247179A	Curva Spinner DB Only	\$2,683	\$2,683.00

Total Equipment Cost at State Contract Pricing

\$44,096.00



City of Rogers
 22350 S.Diamond Lake Rd.
 Rogers, MN 55374
 Mike Bauer - Parks & Recreation Director

PRELIMINARY BUDGET - THIS IS AN ESTIMATE & NOT A FORMAL QUOTE

	Preliminary Budget	Possible Additions	Possible Reductions	QTY	Notes
Play Equipment					
Crow River Heights Park - Option 1	44,096.00				2025 State Contract Price
State Contract #218091	(2,645.76)			6%	(6% discount under \$80,000 & 8% discount \$80,000 & above)
Sales Tax - if applicable	0.00				ST3 Certificate of Exemption must be provided by owner.
Delivery of Play equipment	600.00				Estimated / Final quote will be provided upon final design.
Mobilization	750.00				Mobilization of Installation Crew to Job Site (Trailer Skid Steer Augur, Tools, Mixer, Etc.)
Dumpster(s) - 30 Yard	750.00				Disposal of packaging material - Deduct if Provided by Owner/Volunteers
Site work	City of Rogers				
Border Options					
Plastic Timbers & Ramp	5,555.95			53	APS plastic timber border with full ramp.
Equipment Installation (Labor & Concrete for Footings)	10,891.69			26.28%	Full professional installation by Landscape Structures Certified Installers. Standard labor rate unless otherwise noted
Concrete Flatwork	TBD				The city may want to consider a concrete or asphalt trail to the entrance of the playground.
Subgrade Prep & Engineered Wood Fiber Surfacing (EWF)					
EWF - Playground Safety Surfacing (CY)	4,995.00			111	IPEMA Certified Meets ASTM, ADA & CPSC - <i>Installed AFTER Fabric</i> - Deduct INSTALL LABOR if by Owner/Volunteers
EWF Freight	800.00				
Rubber Wear Mats	785.55			4	Rubber Wear Mats - Installed AFTER Playground Wood Fiber - Deduct INSTALL LABOR if Completed by Owner/Volunteers
Site Restoration (Sq.Ft.)	City of Rogers			0	Backfilling Req'd to Stabilize Border - Not Responsible for "Movement" - Not Included
Payment & Performance Bonds	0.00				Included By Request
	Preliminary Total	Additions Total	Reductions Total		Total w/ Additions & Reductions
	66,578.43	0.00	0.00		66,578.43

C:\Users\Alexandra\OneDrive\Flagship Recreation\Documents\2026 Planning\Brett\Roger_Crow River Heights\Design\Option 2\Roger_CrowRiverHeights_Opt 2 - 11212.dwg

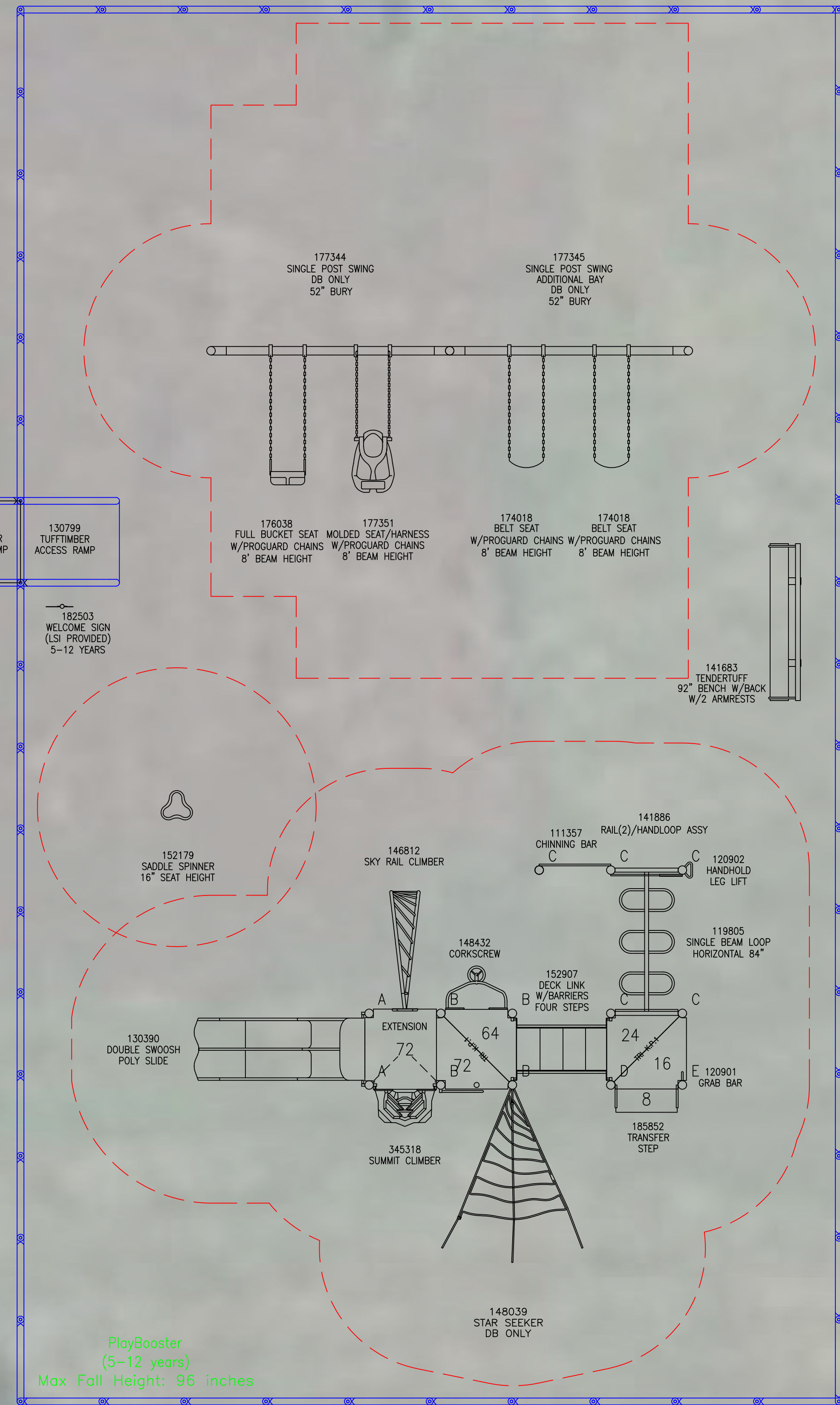
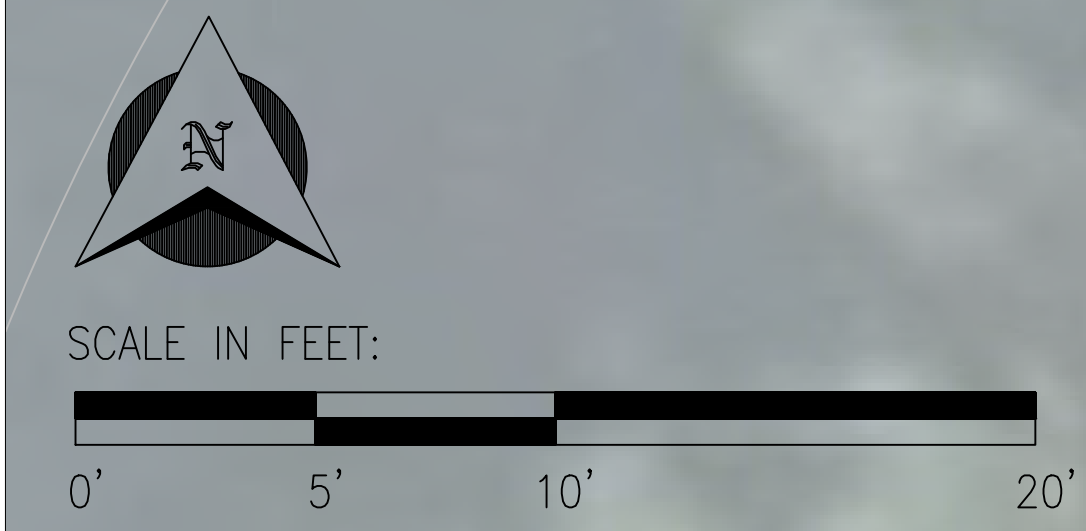

PlayBooster
(5-12 years)
Max Fall Height: 96 inches

CONTAINER DETAILS

TOTAL CONTAINER AREA	2720 SF
ASTM SAFETY SURFACING TYPE	ENGINEERED WOOD FIBER
TOTAL EWF AREA	2720 SF
TOTAL PERIMETER	216 LF
EDGING TYPE	4' PLASTIC TIMBERS
FINISH GRADE	TOP OF CURB

- **SITE PREPARATION REQUIREMENTS:**
- MAXIMUM OF 1% GRADE CHANGE ACROSS CONTAINER
 - NO PRE-INSTALLED DRAIN TILE OUTSIDE OF 4 FEET OF PERIMETER
 - DRAIN TILE STUB TO BE PROVIDED IF DRAIN TILE IS REQUIRED
 - NO DRAINAGE AGGREGATE PRE-INSTALLED
 - NO FABRIC PRE-INSTALLED
 - MINIMUM CONTAINER SIZE NEEDED DENOTES THE INSIDE OF CURB DIMENSION



FLAGSHIP RECREATION
11123 UPPER 33RD ST N
LAKE ELMO, MN 55082
763-550-7860
FLAGSHIPPLAY.COM
@FLAGSHIPPLAY



THIS PLAY AREA & PLAY EQUIPMENT IS
DESIGNED FOR AGE RANGES AS NOTED
ON PLAN.

**CROW RIVER HEIGHTS
PLAYGROUND
OPTION 2**

15150 PARK DR,
DAYTON, MN 55327

**SALES
REPRESENTATIVE:
BRETT ALTERGOTT**

**DESIGNED BY:
AO
11/21/25**

1/4" = 1'-0"

SHEET
LS101

5-12 AREA

TOTAL ELEVATED PLAY COMPONENTS	6		
TOTAL ELEVATED COMPONENTS ACCESSIBLE BY RAMP	0	REQUIRED	0
TOTAL ELEVATED COMPONENTS ACCESSIBLE BY TRANSFER	6	REQUIRED	3
TOTAL ACCESSIBLE GROUND LEVEL COMPONENTS SHOWN	6	REQUIRED	2
TOTAL DIFFERENT TYPES OF GROUND LEVEL COMPONENTS	4	REQUIRED	4





 **landscape structures**

Crow River Heights - Option 2

Roger_CrowRiverHeights Opt 2 - 112125 • 11.21.2025

 **flagship recreation**

© 2025 Landscape Structures. All Rights Reserved



LS landscape structures

Crow River Heights - Option 2

Roger_CrowRiverHeights Opt 2 - 112125 • 11.21.2025



© 2025 Landscape Structures. All Rights Reserved





 **landscape structures**

Crow River Heights - Option 2

Roger_CrowRiverHeights Opt 2 - 112125 • 11.21.2025

 **flagship recreation**

© 2025 Landscape Structures. All Rights Reserved



 **landscape structures**

Crow River Heights - Option 2

Roger_CrowRiverHeights Opt 2 - 112125 • 11.21.2025

 **flagship**
recreation

© 2025 Landscape Structures. All Rights Reserved



 **landscape structures**

Crow River Heights - Option 2

Roger_CrowRiverHeights Opt 2 - 112125 • 11.21.2025

 **flagship recreation**

© 2025 Landscape Structures. All Rights Reserved

PROJECT INFORMATION

Crow River Heights Park

15150 Park Dr,

Dayton, MN 55327

Contract Year: 2026

EQUIPMENT INFORMATION & PRICING

<u>Qty</u>	<u>Item No.</u>	<u>Description</u>	<u>Price</u>	<u>Ext Price</u>
1	111229A	Square Deck Extension	\$1,403	\$1,403.00
1	111357A	Chinning Bar Alum DB	\$770	\$770.00
2	111404A	148"Alum Post DB	\$566	\$1,132.00
4	111404E	116"Alum Post DB	\$444	\$1,776.00
1	111404F	108"Alum Post DB	\$423	\$423.00
1	111404G	100"Alum Post DB	\$418	\$418.00
4	111404M	148"Steel Post DB	\$510	\$2,040.00
1	119805A	Single Beam Loop Horiz Ladder 84"	\$1,505	\$1,505.00
1	120901A	Grab Bar	\$275	\$275.00
1	120902A	Handhold Leg Lift	\$296	\$296.00
2	121949A	Tri-Deck Kick Plate 8"Rise	\$240	\$480.00
4	122197A	90* Triangular Tenderdeck	\$1,239	\$4,956.00
1	130390A	Double Swoosh Slide 72"Dk DB	\$3,381	\$3,381.00
1	141886A	Access/Landing Assembly Rails Barrier Left 24"Dk	\$979	\$979.00
1	146812A	Sky Rail Climber 72"Dk DB	\$2,346	\$2,346.00
1	148039A	Star Seeker DB Only Attached to Square Deck	\$5,253	\$5,253.00
1	148432B	Corkscrew Perm Handholds 64"Dk DB	\$1,846	\$1,846.00
1	152907D	Deck Link w/Barriers Steel end panels 4 Steps	\$4,738	\$4,738.00
1	185852A	Transfer Step w/2 Handloops DB	\$1,448	\$1,448.00

1	345318A	Summit Climber 1 Sides 72"Dk DB	\$1,974	\$1,974.00
1	141683Q	92" TenderTuff Bench w/Back Two Armrests DB	\$1,239	\$1,239.00
1	152179A	Saddle Spinner DB 16"Height	\$1,010	\$1,010.00
2	174018A	Belt Seat ProGuard Chains for 8' Beam Height	\$179	\$358.00
1	176038A	Full Bucket Seat ProGuard Chains for 8' Beam Height	\$500	\$500.00
1	177344A	Single Post Swing Frame 52" Bury 8' Beam Height Only DB Only	\$1,938	\$1,938.00
1	177345A	Single Post Swing Frame 52" Bury Additional Bay 8' Beam Height Only DB Only	\$1,382	\$1,382.00
1	177351A	Molded Bucket Seat (5-12 yrs) w/Harness ProGuard Chains for 8' Beam Height	\$1,219	\$1,219.00
1	182503C	Welcome Sign (LSI Provided) Ages 5-12 years Direct Bury	\$0	\$0.00

Total Equipment Cost at State Contract Pricing

\$45,085.00



City of Rogers
 22350 S. Diamond Lake Rd.
 Rogers, MN 55374
 Mike Bauer - Parks & Recreation Director

PRELIMINARY BUDGET - THIS IS AN ESTIMATE & NOT A FORMAL QUOTE

	Preliminary Budget	Possible Additions	Possible Reductions	QTY	Notes
Play Equipment					
Crow River Heights Park - Option 2	45,085.00				2026 State Contract Price
State Contract #218091	(2,705.10)			6%	(6% discount under \$80,000 & 8% discount \$80,000 & above)
Sales Tax - if applicable	0.00				ST3 Certificate of Exemption must be provided by owner.
Delivery of Play equipment	600.00				Estimated / Final quote will be provided upon final design.
Mobilization	750.00				Mobilization of Installation Crew to Job Site (Trailer Skid Steer Augur, Tools, Mixer, Etc.)
Dumpster(s) - 30 Yard	750.00				Disposal of packaging material - Deduct if Provided by Owner/Volunteers
Site work	City or Rogers				
Border Options					
Plastic Timbers & Ramp	5,628.51			55	Installed "On Grade" (Not Buried) unless Otherwise Noted. Materials Only / Install Labor Included in Equip Install
Equipment Installation (Labor & Concrete for Footings)	12,366.04			29.18%	Full professional installation by Landscape Structures Certified Installers. Standard labor rate unless otherwise noted
Concrete Flatwork	TBD				The city may want to consider a concrete or asphalt trail to the entrance of the playground
Subgrade Prep & Engineered Wood Fiber Surfacing (EWF)					
EWF - Playground Safety Surfacing (CY)	5,310.00			118	IPEMA Certified Meets ASTM, ADA & CPSC - <i>Installed AFTER Fabric</i> - Deduct INSTALL LABOR if by Owner/Volunteers
EWF Freight	800.00				
Rubber Wear Mats	785.55			4	Rubber Wear Mats - Installed AFTER Playground Wood Fiber - Deduct INSTALL LABOR if Completed by Owner/Volunteers
Site Restoration (Sq.Ft.)	City or Rogers			0	Backfilling Req'd to Stabilize Border - Not Responsible for "Movement" - Not Included
Payment & Performance Bonds	0.00				Included By Request
	Preliminary Total	Additions Total	Reductions Total		Total w/ Additions & Reductions
	69,370.00	0.00	0.00		69,370.00



STAFF REPORT

ROGERS PARKS AND RECREATION ADVISORY COMMISSION

Meeting Date: December 11, 2025

Agenda Item: 6.6

Subject: Consider the Student Liaison Application

Prepared By: Mike Bauer, Parks & Recreation Director

Overview / Background / Analysis

The Student Liaison position serves as a non-voting member of the Parks and Recreation Advisory Commission and provides valuable youth perspective on park planning, programming, and facility operations. The position also supports leadership development for local students and encourages civic engagement within the community.

An application has been received from a Rogers High School student interested in serving in this role.

Applicant:

Abigail Reilly

Residence: Rogers, MN

Current Grade: Sophomore

Commission Action Requested

Commissioners are asked to:

1. Review the submitted application.
2. Discuss the qualifications and interest of the applicant.
3. Make a recommendation for the appointment of the Student Liaison

Staff Recommendation

Financial Impact:

Source Fund:

Budgeted?

Supporting Documentation
A. Abigail Reilly Application

Name * Abigail Reilly

Address *

Rogers, MN 55374

United States

What year of High School are you currently in? * Sophomore

Please briefly describe your interests as it relates to Parks and Recreation. * As a cross country runner it is very important to me to have clean, safe, public trails and parks that everyone can enjoy. I would love to be able to contribute to improving and maintaining these public spaces that allow our community to connect with nature.

Why you would like to serve as a Student Representative on the Parks and Recreation

Advisory Commission? * I am in involved in the Rogers chapter of the YMCA youth in government and over the course of my time in the program I have become incredibly passionate about youth advocacy. I think it is so important for the younger generations to have their voices heard, especially when the decisions being made will impact their lives as they near adulthood. I would love to be a mouth peice for my peers and be able to contribute their ideas, as well as my own, to the conversation.



STAFF REPORT

ROGERS PARKS AND RECREATION ADVISORY COMMISSION

Meeting Date: December 11, 2025

Agenda Item: 6.7

Subject: Consider Summer Rental Request for South Community Park Rink(s)

Prepared By: Mike Bauer, Parks & Recreation Director

Overview / Background / Analysis

Staff received a rental inquiry from Austin Powell, Assistant Varsity Lacrosse Coach at Rogers High School, seeking to use the outdoor hockey rinks at South Community Park during the summer season to introduce box lacrosse programming for youth and high school players in Rogers and the surrounding northwest suburbs.

Mr. Powell is a former professional box lacrosse player in Canada, a four-year NCAA Division I student athlete, and has more than 15 years of coaching experience. He indicated a need for local access to facilities that support box lacrosse opportunities, noting that participants currently must travel to the south metro or downtown areas for comparable training opportunities.

Proposed Program Use

The request includes the following rental parameters:

- Three weeknights per week for three hours per night
- Preferred schedule: Monday, Tuesday, and Thursday from 5:30 pm–8:30 pm
- Initial rental of one rink with a request to expand to a second rink as participation grows
- Programming would serve both boys' and girls' participants at youth and high school levels

Operational Review

Should the Commission wish staff to continue evaluation of this request, next steps would include:

- Reviewing rental rates consistent with existing facility fee schedules
- Clarifying insurance requirements and user agreements
- Determining staffing or lighting operational adjustments if required
- Developing parameters for any future expansion to a second rink based on defined utilization thresholds

Commission Direction Requested

At this time, staff is seeking general direction from the Parks Commission on whether to proceed with formal negotiations and schedule review for this proposed program rental. No binding agreement would be executed without further staff analysis and any necessary approvals.

Commission input will help guide whether this opportunity should move forward toward formal scheduling evaluation and potential trial programming for Summer 2026.

Staff Recommendation

Financial Impact:

Source Fund:

Budgeted?

Supporting Documentation

None



STAFF REPORT

ROGERS PARKS AND RECREATION ADVISORY COMMISSION

Meeting Date: December 11, 2025

Agenda Item: 6.8

Subject: Consider Park and Parking Lot Lighting Plans

Prepared By: Mike Bauer, Parks & Recreation Director

Overview / Background / Analysis

The purpose of this agenda item is to introduce a preliminary discussion regarding opportunities to expand or improve lighting within City parks, trails, and associated parking areas. Staff is seeking input on community priorities to help guide future planning, budgeting, and implementation strategies. Additional technical and cost details will be provided at the meeting.

As Rogers continues to invest in its parks and trail system, use of amenities during early morning, evening, and shoulder-season hours continues to grow. Adequate lighting is an important component of providing safe, accessible, and welcoming public spaces. Well-lit trails and parking areas support personal safety, visibility, wayfinding, and emergency access, while encouraging year-round use of facilities. Lighting is also a consistent topic raised by residents in conversations related to comfort and perceived safety within the park system.

Currently, lighting across the system varies significantly. Some park parking lots and building areas are well illuminated, while many trail corridors and portions of parks remain unlit or only receive ambient lighting from nearby development. With upcoming investments in parks and trail connections, this is an appropriate time to consider a coordinated approach to future lighting improvements.

Staff is seeking guidance on the following:

- Prioritization among parks, trails, and parking lots for future lighting enhancements.
- Identification of locations perceived as most important or most in need of lighting improvements.
- Whether future lighting projects should be pursued incrementally as part of capital projects, or through a broader system-wide master planning effort.

Next Steps

Following commission input, staff will refine priority locations, confirm design standards, develop preliminary cost estimates, and return with more detailed recommendations and potential funding options for consideration during future budget and capital planning discussions.

Staff Recommendation

Financial Impact:

Source Fund:

Budgeted?

Supporting Documentation

- A. LS952-4352 Lion's Central Park
- B. LS952-4334-3 Territorial Park
- C. LS952-4349-3 Tennis Club Parking
- D. MINNESOTA25150611_ROGPARK2217756972953276908
- E. City_of_Rogers__Territorial_Park__LS95243343_SINGLE



Scale: 1 inch= 60 Ft.



Scale: 1 inch= 60 Ft.

Symbol	Qty	Label	Arrangement	Description	LLF	Luminaire Lumens	Luminaire Watts	Total Watts	Tag
AR13-48N-MV-NW-3-XX-060	4	48N-MV-NW-3	Single	AR13-48N-MV-NW-3-XX-060	0.900	5880	40	160	MH = 15ft
AR13-48N-MV-NW-2-XX-060	20	48N-MV-NW-2	Single	AR13-48N-MV-NW-2-XX-060	0.900	5880	40	800	MH = 15ft
AR13-48N-MV-NW-5-XX-060	1	48N-MV-NW-5	Single	AR13-48N-MV-NW-5-XX-060	0.900	5880	40	40	MH = 15ft

Calculation Summary							
Label	CalcType	Units	Avg	Max	Min	Avg/Min	Max/Min
CalcPts	Illuminance	Fc	1.6	6.2	0.1	15.8	62.0

These drawings are for conceptual use only and are not intended for construction. Fixture runs and quantities should be verified prior to order. Values represented are an approximation generated from manufacturers photometric inhouse or independent lab tests with data supplied by lamp manufacturers.



#	Date	Comments

Revisions

Drawn By: Joe Frey
Checked By:
Date: 10/29/2025
Sales Agent: Jerry Strand
As Shown

Lions Central Park
Rogers, MN

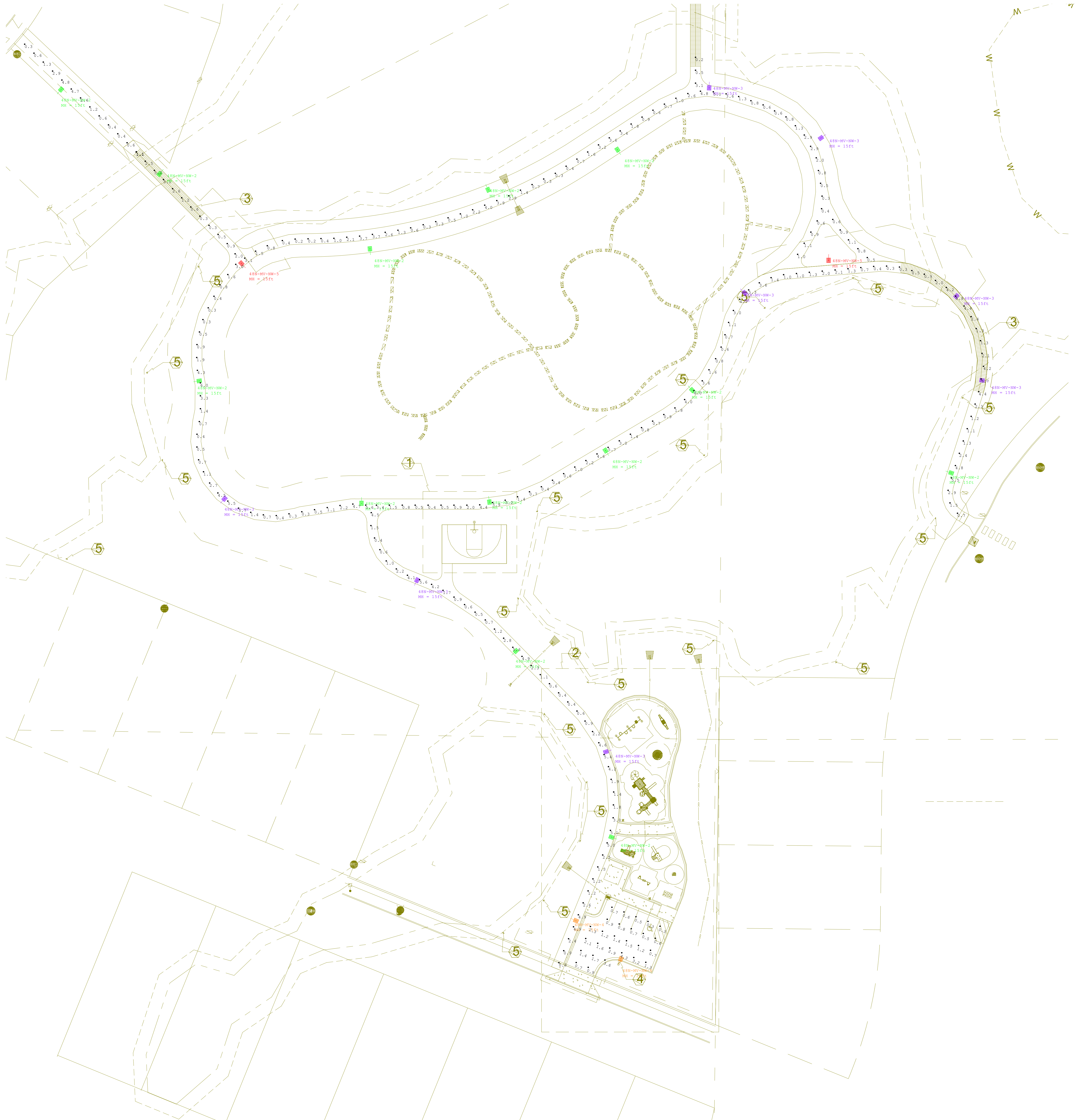

Scale: 1 inch= 30 Ft.

Symbol	Label	Arrangement	Lum. Lumens	L/F	Description	Lum. Watts	Air. Watts	Total Watts	Foot
1	488-WV-00-4	Single	5880	0.900	ARI-3-488-WV-00-4-XX-0-60	40	40	80	MH = 15ft
2	488-WV-00-4	Single	5880	0.900	ARI-3-488-WV-00-4-XX-0-60	40	40	80	MH = 15ft
3	488-WV-00-5	Single	5880	0.900	ARI-3-488-WV-00-5-XX-0-60	40	40	80	MH = 15ft
4	488-WV-00-5	Single	5880	0.900	ARI-3-488-WV-00-5-XX-0-60	40	40	80	MH = 15ft
5	488-WV-00-3	Single	5880	0.900	ARI-3-488-WV-00-3-XX-0-60	40	40	80	MH = 15ft
6	488-WV-00-3	Single	5880	0.900	ARI-3-488-WV-00-3-XX-0-60	40	40	80	MH = 15ft
7	488-WV-00-3	Single	5880	0.900	ARI-3-488-WV-00-3-XX-0-60	40	40	80	MH = 15ft
8	488-WV-00-3	Single	5880	0.900	ARI-3-488-WV-00-3-XX-0-60	40	40	80	MH = 15ft
9	488-WV-00-3	Single	5880	0.900	ARI-3-488-WV-00-3-XX-0-60	40	40	80	MH = 15ft
10	488-WV-00-3	Single	5880	0.900	ARI-3-488-WV-00-3-XX-0-60	40	40	80	MH = 15ft
11	488-WV-00-3	Single	5880	0.900	ARI-3-488-WV-00-3-XX-0-60	40	40	80	MH = 15ft
12	488-WV-00-3	Single	5880	0.900	ARI-3-488-WV-00-3-XX-0-60	40	40	80	MH = 15ft
13	488-WV-00-3	Single	5880	0.900	ARI-3-488-WV-00-3-XX-0-60	40	40	80	MH = 15ft
14	488-WV-00-3	Single	5880	0.900	ARI-3-488-WV-00-3-XX-0-60	40	40	80	MH = 15ft
15	488-WV-00-3	Single	5880	0.900	ARI-3-488-WV-00-3-XX-0-60	40	40	80	MH = 15ft
16	488-WV-00-3	Single	5880	0.900	ARI-3-488-WV-00-3-XX-0-60	40	40	80	MH = 15ft
17	488-WV-00-3	Single	5880	0.900	ARI-3-488-WV-00-3-XX-0-60	40	40	80	MH = 15ft
18	488-WV-00-3	Single	5880	0.900	ARI-3-488-WV-00-3-XX-0-60	40	40	80	MH = 15ft
19	488-WV-00-3	Single	5880	0.900	ARI-3-488-WV-00-3-XX-0-60	40	40	80	MH = 15ft
20	488-WV-00-3	Single	5880	0.900	ARI-3-488-WV-00-3-XX-0-60	40	40	80	MH = 15ft

Label	CalcType	Units	Avg	Max	Min	Avg/Min	Max/Min
Path	illum	fc	1.9	6.0	0.2	9.5	30.0

Page Size: 36 x 44	Project: Territorial Park, Rogers MN	Luma Sales: Jerry Strand Layout By: Joe Frey	Luma Sales Associates <i>Lighting and Controls</i>
IPA-d.com Project # LS952-4334	These drawings are for conceptual use only and are not intended for construction. Fixture runs and quantities should be verified prior to order. Values represented are an approximation generated from manufacturers photometric inhouse or independent lab tests with data supplied by lamp manufacturers.	Date: 10/20/2025 Filename: LS952-4334 Territorial Park.AGI	

GROUND
RESERVOIR

DRAINAGE SWALE

R212.00

R20.00

R18.00

R18.00

R20.00

55 LF 12" RCP CLASS III
PIPE @ 1.27%
INV W= 901.20
INV E= 900.50

27 LF 15" CM
PIPE @ 0.37%
INV W= 899.50
INV E= 899.40

130 LF 12" CM
PIPE @ 0.46%
INV S= 898.60
INV N= 898.00

12" RC APRON
INV= 897.60

129 LF 12" RCP CLASS III
PIPE @ 2.79%

12" RC APRON
INV=894.00

SWALE

DRAINAGE SWALE

14TH AVENUE N

80'

360'

Scale: 1 inch= 20 Ft.

Luminaire Schedule									
Symbol	Qty	Label	Arrangement	Description	LLF	Luminaire Lumens	Luminaire Watts	Total Watts	Tag
■	3	AR18	Single	AR18-96N-MV-NW-4-XX-400	0.900	37959	300.605	901.815	MH = 25ft

Calculation Summary							
Label	CalcType	Units	Avg	Max	Min	Avg/Min	Max/Min
CalcPts	Illuminance	Fc	0.9	11.9	0.0	N.A.	N.A.

These drawings are for conceptual use only and are not intended for construction. Fixture runs and quantities should be verified prior to order. Values represented are an approximation generated from manufacturers photometric inhouse or independent lab tests with data supplied by lamp manufacturers.



#	Date	Comments

#	Date	Comments

Drawn By: Joe Frey
Checked By:
Date: 10/28/2025
Sales Agent: J Strand
Scale: 1" = 20'

Tennis Club Parking



Luma Sales Associates, Inc.
 5200 12th Avenue East
 Shakopee MN 55379
 Phone: (952) 995-6500
 Fax: (952) 995-6565

Date: Dec 10, 2025

Project City of Rogers - Territorial Park - LS952-4334-3 **From: Sarah Anderson**
Location - Solar w/19' Pole, 15' MH
 Rogers MN
Quote MINNESOTA25-150611-4

To: Mike Bauer
 City of Rogers Parks & Recreation Depa
 22350 South Diamond Lake Road
 Rogers MN 55374
 Phone: (763) 428-0975
 EMail: mbauer@rogersmn.gov

For
Bid Date Dec 9, 2025
Expires Jan 8, 2026

Remarks:

PLUS FREIGHT ON SHAKESPEARE, LEOTEK, TRADITIONAL CONCRETE (ESTIMATED AT \$1075 FOR TC) & CLEAR BLUE (ESTIMATED AT \$700 FOR CB) IN ADDITION TO COSTS BELOW.

QTY	Type	MFG	Part	Price	UQ	ExtPrice
Note			BUDGET PRICING			
Note			CLEAR BLUE RENEWAL FEE STARTING IN YEAR 4 - \$131.55 PER POLE PER YEAR.			
1			FIBERGLASS INCLUDES:	\$7,925.00		\$7,925.00
1	POLE	SHAKE	BH19-00S1 15' MH, DRILLED FOR ONE FIXTURE	(included)		-
1	FIXTURE	LEOTEK	AR13-48N-MV-NW-2-BK-060-MLS7-RPA	(included)		-
1	SOLAR	CLEARBLUE	CLEAR BLUE SOLAR PACKAGE POWER PACK, BATTERY, SOLAR PANEL, BATTERY CABINET, CABLING KIT, CONTROLLER	(included)		-
Line Note: Illumient Power Pack Single Solar Off Grid System(based on 1 unit)						
1			CONCRETE INCLUDES:	\$8,248.00		\$8,248.00
1	POLE	TRADCONC	D315-DB-EA-FI Direct burial, 300 series, round, 15' above ground, dark black colored, etched finish, concrete pole with acrylic seal, finial top, and side inserts.	(included)		-
1	FIXTURE	LEOTEK	AR13-48N-MV-NW-2-BK-060-MLS7-RPA	(included)		-
1	SOLAR	CLEARBLUE	CLEAR BLUE SOLAR PACKAGE POWER PACK, BATTERY, SOLAR PANEL, BATTERY CABINET, CABLING KIT, CONTROLLER	(included)		-
Line Note: Illumient Power Pack Single Solar Off Grid System(based on 1 unit)						

Terms and conditions of sale:

TERMS and CONDITIONS:

THIS QUOTATION IS A SOLICITATION FOR OFFER ONLY AND IS TO BE USED BY THE RECIPIENT FOR PURPOSES OF QUOTE PREPARATION. ANY DISCLOSURE TO A THIRD PARTY OF THE INFORMATION CONTAINED HEREIN IS PROHIBITED.

*** PLEASE REFER TO THIS QUOTATION BY QUOTE NUMBER WHEN ORDERING. ***

****TARIFFS:**

Please note that this quote/email does not account for any tariffs that may be imposed after the quoted



Luma Sales Associates, Inc.
5200 12th Avenue East
Shakopee MN 55379
Phone: (952) 995-6500
Fax: (952) 995-6565

Date: Dec 10, 2025

Project City of Rogers - Territorial Park - LS952-4334-3 **From: Sarah Anderson**
Location - Solar w/19' Pole, 15' MH
 Rogers MN
Quote MINNESOTA25-150611-4

To: Mike Bauer
 City of Rogers Parks & Recreation Depa
 22350 South Diamond Lake Road
 Rogers MN 55374
 Phone: (763) 428-0975
 EMail: mbauer@rogersmn.gov

For
Bid Date Dec 9, 2025
Expires Jan 8, 2026

date. To ensure complete transparency and accuracy, a revised quotemay be issued at the time of order release, reflecting any potential tariff impacts.

NOTE: Pricing is based on a complete package, ONE SHIPMENT, and cannot be separated without prior approval from Luma Sales.

- 1) This quote is subject to manufacturer's published terms and conditions of sale and is subject to change without notice
- 2) Pricing valid for 30-days to order / 90-days to release and Void if changed. Quotes are based on one release per manufacturer. Split shipments may be subject to freight charges.
- 3) Prices do not include lamps, spare materials, fuses, special finishes, installation, or applicable taxes and are shipped with standard finishes unless specifically noted differently on this quote.
- 4) This quote does not include any addenda unless otherwise noted.
- 5) MANUFACTURERS STANDARD FREIGHT TERMS APPLY. Freight damage claims are the responsibility of the customer. Freight claims must be filed with in 5-Business Days of receipt.
- 6) LUMA SALES is not responsible for labor charges. A labor estimate must be submitted and approved by manufacturer prior to work being performed. Chargebacks are not honored without prior written approval from the Manufacturer.
- 7) Add freight for PRESHIPMENT of ANCHOR BOLTS and BACK BOXES.
- 8) All CONCRETE products are PLUS freight unless otherwise noted.
- 9) CUSTOM products require a deposit and payment in full prior to shipping with no returns or cancellations allowed.
- 10) Errors and omissions are subject to correction. LUMA SALES is not responsible for fixture or control device counts.

11



H-SERIES

Composite Light pole

H-Series

Direct Burial

**ROUND TAPERED COMPOSITE LIGHT POLE
DIRECT BURIAL INSTALLATION**

SHAKESPEARE H-SERIES DIRECT BURIAL POLES

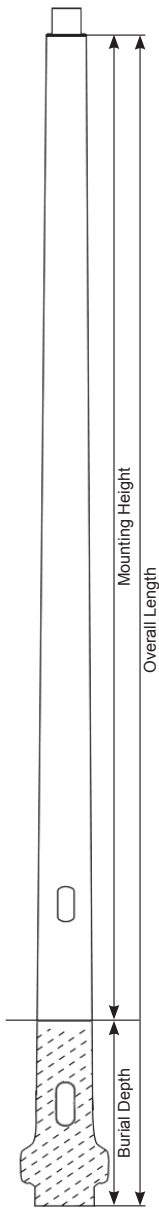

OVERALL LENGTH	MOUNTING HEIGHT	BURIAL DEPTH	TIP DIAMETER	GROUNDLINE DIAMETER	WEIGHT
13	10	3	4.6	6.0	39
14	11	3	4.6	6.1	45
15	12	3	4.6	6.2	51
16	13	3	4.6	6.4	54
18	14	4	4.6	6.5	58
19	15	4	4.6	6.7	65
20	16	4	4.6	6.8	68
21	17	4	4.6	6.9	72
22	18	4	4.6	7.1	76
23	19	4	4.6	7.2	80
24	20	4	4.6	7.3	85
25	21	4	4.7	7.3	102
26	22	4	4.7	7.6	106
27	23	4	4.7	7.8	109
28	24	4	4.7	7.9	113
30	25	5	4.7	8.0	117
31	26	5	4.7	8.2	121
32	27	5	4.7	8.3	125
33	28	5	4.7	8.3	128
34	29	5	4.7	8.4	132
35	30	5	4.7	8.4	136

- Mounting heights to 30 feet
- Smooth, semi-smooth or natural finish
- 3 standard and 5 special architectural colors available
- High performance UV and weather-resistant pigmented resin system with an additional pigmented polyurethane coating.
- Tenon top or Drilled and Capped
- Standard 2-1/2" x 5" handhole located 18" above grade
- Standard 2 EA - 2-1/2" x 6" wire access hole 24" below grade
- Anti-rotation flare structurally integrated into the pole base during manufacture
- Poles are individually identified with a permanent embossed tag located 9" from tip.
- Sleeved individually for shipment
- Lightweight, easy to install, saves money

ORDERING INFORMATION

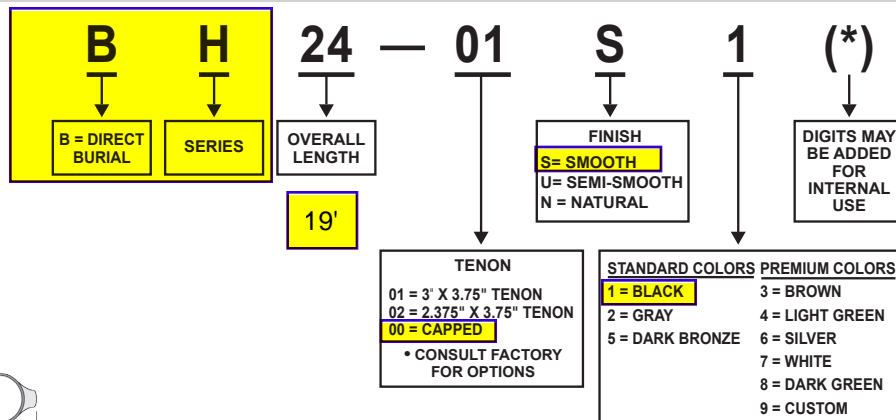



Composite Light pole

H-SERIES



ROUND TAPERED COMPOSITE LIGHT POLE - DIRECT BURIAL INSTALLATION

SPECIFICATIONS

1. Lighting poles shall be fiberglass reinforced composite per Shakespeare design.
2. Wind loading shall be calculated for the appropriate wind velocity with a 3 second gust factor per ASCE.
3. Effective projected area (EPA) is the actual area adjusted with the appropriate drag coefficient (shape factor) to result in an equivalent area having a drag coefficient equal to one (1) using ANSI 136.20

MATERIALS

1. The round tapered pole shall be constructed by the filament winding process from thermosetting polyester resin and contain a minimum of 65 percent "E" type fiberglass by weight. The filament windings shall be continuously applied with uniform tension and shall be placed on the pole helically at low angles to provide axial strength. Additional windings shall be placed on the pole in a circular manner to provide compressive strength.
2. The resin to make the pole shall be ultraviolet resistant and pigmented approximately the same color as the final coating to be applied. A highly weather resistant, pigmented, polyurethane coating shall be applied to the pole. The coating shall have a minimum thickness of 1.5 mils.
3. The poles shall be flame resistant per ASTM D635. Specimens must cease to burn before the gauge mark of 100mm (3.9 inches) is reached.
4. (If applicable) The poles shall be delivered predrilled and capped (if applicable) to accommodate the lighting fixture(s) or mast arm(s) specified.
5. (If applicable) Tenons shall be permanently bonded to the fiberglass shaft and shall be hot-dipped galvanized steel to ASTM A153 or shall be 6061-T6 or A356-T6 aluminum.
6. The handhole opening shall be 2.5" x 5". The handhole cover is attached with a 1/4" socket head screw.

IDENTIFICATION & PACKAGING

Each pole shall bear an identification tag which shall list the model, catalog number, month and year of manufacture.
Each pole shall be individually packaged for protection during shipping.

TESTING

The surface shall have been tested for a minimum of 5000 hours of accelerated testing in accordance with ASTM G154 (UV-A Lamp 340 NM wavelength 130° F, cycle lamp 4 hours on, 4 hours off) with the following performance results:

- Fiber exposure: None | Cracking: None | Chalking: None | Color: Slight dulling may occur

WIND LOADING DATA

Wind speed (mph) values calculated as per ANSI C136.20 for a 3-second gust factor.

OVERALL LENGTH	MOUNTING HEIGHT	LUMINAIRE MAX WEIGHT (LBS.)	90 MPH	100 MPH	110 MPH	120 MPH	130 MPH	140 MPH	150 MPH
13	10	150	19.1	15.3	12.6	10.5	8.8	7.6	6.5
14	11	150	18.7	15.0	12.3	10.2	8.6	7.4	6.3
15	12	150	18.3	14.7	12.0	10.0	8.4	7.2	6.2
16	13	150	17.9	14.4	11.7	9.7	8.2	7.0	6.0
18	14	150	17.6	14.0	11.4	9.5	8.0	6.8	5.8
19	15	150	19.7	15.7	12.8	10.7	9.0	7.6	6.6
20	16	200	19.2	15.3	12.5	10.4	8.7	7.4	6.4
21	17	200	18.6	14.8	12.1	10.0	8.4	7.1	6.1
22	18	200	18.0	14.3	11.7	9.7	8.1	6.9	5.9
23	19	200	17.4	13.9	11.3	9.3	7.8	6.6	5.7
24	20	200	16.9	13.5	10.9	9.0	7.6	6.4	5.5
25	21	200	14.2	11.2	9.1	7.5	6.2	5.3	4.5
26	22	200	13.3	10.5	8.5	7.0	5.8	4.9	4.1
27	23	200	12.4	9.8	7.9	6.5	5.4	4.5	3.8
28	24	200	11.7	9.2	7.4	6.0	5.0	4.2	3.4
30	25	200	10.9	8.6	6.9	5.6	4.6	3.8	3.1
31	26	200	10.3	8.0	6.4	5.2	4.3	3.6	2.9
32	27	200	9.6	7.5	6.0	4.8	4.0	3.3	2.5
33	28	200	9.1	7.0	5.6	4.5	3.7	3.0	2.3
34	29	200	8.5	6.6	5.2	4.1	3.4	2.7	2.0
35	30	200	7.9	6.1	4.8	3.8	3.1	2.5	1.9

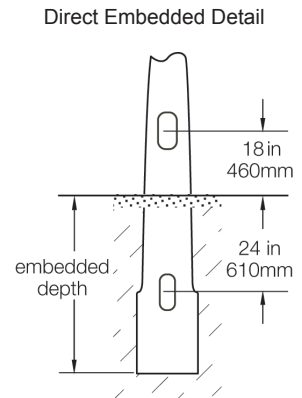



300 Series

- Spun round
- 1/8" taper per foot
- Available in lengths up to 36'

Pole Dimensions

Pole No.	[A] Above Ground Height	[B] Burial Depth	[C] Tip Diameter	[D] Base Diameter	Est. Pole Weight (lbs)*
D312	12'	5'	5"	6-1/2"	500
D313	13'	5'	5"	6-5/8"	550
D315	15'	5'	5"	6-7/8"	600
D316	16'	5'	5"	7"	650
D317	17'	5'	5"	7-1/8"	700
D318	18'	5'	5"	7-1/4"	775
D320	20'	5'	5"	7-1/2"	850
D323	23'	5'	5"	7-7/8"	1,000
D324	24'	5'	5"	8"	1,050
D325	25'	5'	5"	8-1/8"	1,100
D328	28'	5'	5"	8-1/2"	1,300
D330	30'	6'	5"	8-3/4"	1,450

*Pole weight may vary based on color of aggregate.

Pole Code

Mounting Type	Series + Above Ground Height	Color	Finish	Sealer	Options
(D) Direct Burial (A) Anchor Base	312 313 315 316 317 318 320 323 324 325 328 330	(SG) Sky Gray (PG) Pearl Gray (SP) Salt & Pepper (CN) Cinnamon (BZ) Bronze (CB) Charcoal Black (MS) Midnight Sky Black (EB) Eclipse Black (DB) Dark Black (SR) Sedona Red (AR) Antique Red (RG) Red Granite (TC) Terra Cotta (KG) Kelly Green (AW) Alpine White	(E) Etched	(A) Acrylic (W) Waterseal (G) Anti-Graffiti	(B) Banner Arm (F) Finial (I) Threaded Insert (O) Outlet (T) Tenon (TEA) Tapered Elliptical Arm Standard tenon size 2-7/8" OD x 3" tall

Example Code: **D312** - **SG** - **EA** - **3T**

Base Detail

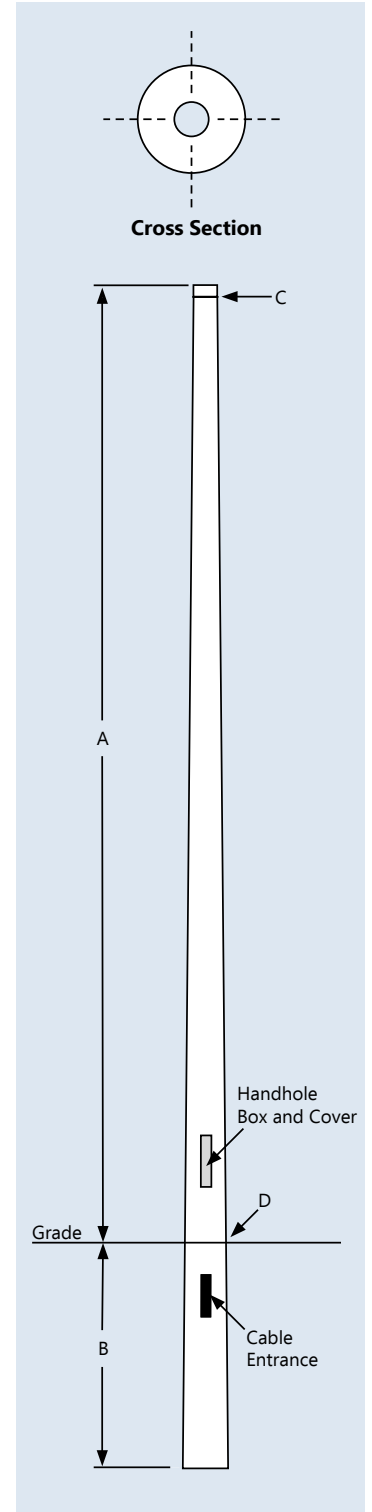
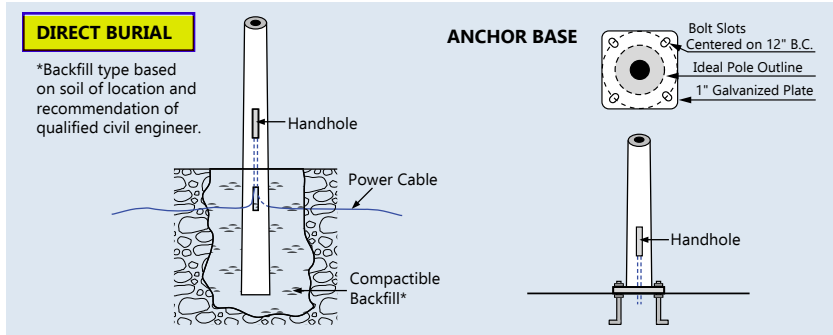

TRADITIONAL CONCRETE, INC.
Street Light Poles

PO Box 157
W142 N9110 Fountain Blvd.
Menomonee Falls, WI 53052-0157
(888) 719-7599
(262) 250-7598 fax
info@concretepoles.com
www.concretepoles.com



Project
Type
Catalog No.

ARIETA® 13 Architectural LED Area Luminaire
AR13 N-Series Specification Data Sheet

Luminaire Data

Weight 15.4 lbs [7 kg]
EPA 0.47 ft²

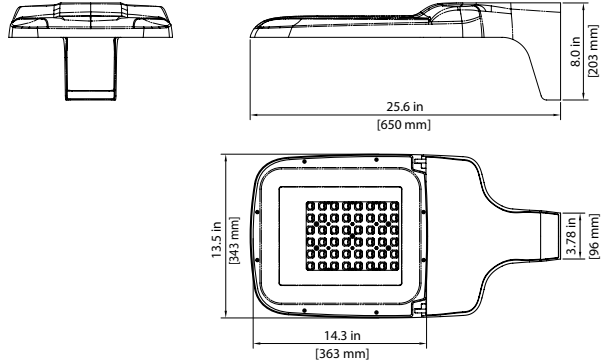

Ordering Information

Sample Catalog No. AR13 48N MV NW 5 BK 190 MSL3

Product	LED Code	Voltage	Nominal Color Temperature	Distribution	Finish ¹	Output Code ²	Options
AR13	48N	MV 120-277V	WW 3000K	2 Type 2 3 Type 3 4 Type 4 5 Type 5 AFR Auto Front Row	BK Black DB Dark Bronze (RAL6022) DB1 Dark Bronze (RAL8019) WH White GY Gray NA Natural Aluminum	WW - 3000K	BLS ³ Back Light Shield (Factory Installed)
		HV 347-480V				CONFIRM	030 Fixed Output Code 040 NEMA Photocontrol Receptacle 055 ANSI 7-wire Photocontrol Receptacle 080 Control Ready 7-wire Photocontrol Receptacle 100 120 150 170 190
		NW 4000K	NW 4000K			NW - 4000K	MSL7 ⁷ Motion Sensor with L7 Lens
		CW 5000K	CW 5000K			CW - 5000K	MSL3 ⁷ Motion Sensor with L3 Lens
						030 040 060 080 100 120 160 190 200	SP2 20kV/10kA Surge Protector PND1 ⁸ Part-Night Dimming PND2 ⁸ Part-Night Dimming PND3 ⁸ Part-Night Dimming ORR Optics Rotated Right ORL Optics Rotated Left WL Utility Wattage Label CF ¹¹ Coastal Paint Finish

- Black, Dark Bronze, White, Gray, or Natural Aluminum standard. DB (RAL6022) is our original dark bronze. DB1 (RAL8019) is a new dark bronze option. Consult factory for other finishes. See page 2 for specifications.
- Specified output code set at the factory set. Includes fixture mounted output selector that enables field adjustable light levels.
- Flush mounted enhanced back light shield, factory installed.
- No field adjustable output. Specified output code set at the factory.
- Includes output selector that enables field adjustability of light levels. Field changeable connectors included to enable dimming connection to PCR7 (wireless node dimming is disabled by default).
- Control-ready wired at factory for wireless node dimming. Output selector not included in fixture. Not able to adjust above specified drive current.
- See L7 or L3 Lens coverage details on page 4. Consult factory for MS specified with ANSI 7-wire Photocontrol Receptacle. PCR option is required for On/Off control using light detection. Not available in HV.
- For PND profile options see page 5. Only available with MV (120-277V).
- Specify Color (GY, DB, DB1, BK, WH, NA)
- Specify MV (120-277V) or HV (347V-480V)
- Specify the CF Option for coastal installation. See warranty for details.

Accessories*	
BLS	Enhanced Back Light Shield
RPA ⁹	Round Pole Adapter
PTF1 ³	Square Pole Top Fitter Single
PTF2 ³	Square Pole Top Fitter Twin at 180°
PTF4 ³	Square Pole Top Fitter Quad
WM ⁹	Wall Mount
BSK	Bird Deterrent Spider Kit
LLPC ¹⁰	Long-Life Twist Lock Photocontrol
SC	Twist Lock Shorting Cap
FSIR100	Motion Sensor Configuration Tool

*Accessories are ordered separately and not to be included in the catalog number





ARIETA® 13 Architectural LED Area Luminaire AR13 N-Series Specification Data Sheet

Luminaire Specifications

Housing

Die cast aluminum housing with universal mounting design allows for attachment to existing pole without redrilling for retrofit applications. Aluminum housing provides passive heat-sinking of the LEDs and has upper surfaces that shed precipitation. Mounting provisions meet 3G vibration per ANSI C136.31-2010 Normal Application, Bridge & Overpass. Electrical components are accessed without tools and are mounted on removable power door.

Light Emitting Diodes

Hi-flux/Hi-power white LEDs produce a minimum of 90% of initial intensity at 100,000 hours of life based on IES TM-21. LEDs are tested in accordance with IES LM-80 testing procedures. LEDs have correlated color temperature of 3000K, 4000K, or 5000K and 70 CRI minimum. LEDs are 100% mercury and lead free.

Field Adjustability

An output selector is supplied to adjust light output for local conditions (not available with PCR7-CR option). The specified output code will be factory set.

Quality Control

Every luminaire is performance tested before and after a 2-hour burn-in period. Assembled in the USA.

Optical Systems

Micro-lens optical systems are fully sealed to maintain an IP66 rating. Luminaire produces 0% total lumens above 90° (BUG Rating, U=0). Auto Front Row (AFR) optics are designed to enhance light levels at site perimeter while minimizing wattage and backlight. Optional enhanced Back Light Shield (BLS) is designed to meet strict light trespass and LEED requirements. Optics may be rotated right or left with options ORR/ORL, respectively

Electrical

Rated life of electrical components is 100,000 hours. Uses isolated power supply that is 1-10V dimmable. Power supply is wired with quick-disconnect terminals. Power supply features a minimum power factor of .90 and <20% Total Harmonic Distortion (THD). EMC meets or exceeds FCC CFR Part 15. Terminal block accommodates 6 to 14 gauge wire. Standard surge protection complies with IEEE/ANSI C62.41 and ANSI C136.2-2015, Enhanced (10kV/5kA). SP2 option provides Extreme level (20kV/10kA).

Controls

3-Wire photocontrol receptacle (PCR) is available. ANSI C136.41 7-wire (PCR7) photocontrol receptacles are available. All photocontrol receptacles have tool-less rotatable bases. Wireless control module is provided by others.

Finish

Housing receives a fade and abrasion resistant polyester powder coat finish with 3.0 mil nominal thickness. Finish tested to withstand 5000 hours in salt spray exposure per ASTM B117 B117 and Coastal Finish per ASTM G85. Finish meets scribe creepage rating 8 per ASTM D1654. Finish tested 500 hours in UV exposure per ASTM G154 and meets ASTM D523 gloss retention.

Listings/Ratings/Labels

Luminaires are UL listed for use in wet locations in the United States and Canada. International Dark Sky Association listed. Luminaire is qualified to operate at ambient temperatures of -40°C to 40°C.

Photometry

Luminaires photometrics are tested by certified independent testing laboratories in accordance with IES LM-79 testing procedures.

Warranty

10-year limited warranty is standard on luminaire and components. 5-year limited warranty on luminaires and components with a motion sensor.

Standards

Luminaire complies with:
ANSI: C136.2, C136.3, C136.10, C136.13, C136.15, C136.22, C136.31, C136.35, C136.37, C136.41, C62.41, C78.377, C82.77
Other: FCC 47 CFR, IEC 60598, ROHS II, UL 1449, UL 1598

Color Specifications

Order Code	Color	RAL #	Pantone Equivalent
GY	Gray	7040	429C
BK	Black	9004	426C
DB	Dark Bronze	6022	BLACK 2C
DB1	Dark Bronze	8019	412
WH	White	9003	11-0601
NA	Natural Aluminum	9006	N/A



ARIETA® 13 Architectural LED Area Luminaire AR13 N-Series Specification Data Sheet

Performance Data 3000K

All data nominal. IES files are available at leotek.com.

LED Code	Output Code	Drive Current (mA)	System Wattage (W)	Delivered Lumens (Lm) ¹	Efficacy (Lm/W)	Field Adjustable Output Range ²
48N	030	120	22	2970	135	↑ ↓
	040	170	29	4020	139	
	055	230	39	5500	141	
	080	350	52	7500	144	
	100	500	72	9930	138	↑ ↓
	120	620	88	12090	137	
	150	800	113	15020	133	
	170	940	138	17680	128	
	190	1050	149	19200	129	

Performance Data 4000K & 5000K

All data nominal. IES files are available at leotek.com.

LED Code	Output Code	Drive Current (mA)	System Wattage (W)	Delivered Lumens (Lm) ¹	Efficacy (Lm/W)	Field Adjustable Output Range ²
48N	030	120	22	3160	144	↑ ↓
	040	170	29	4370	151	
	060	230	39	5900	151	
	080	350	52	7890	152	
	100	500	72	10900	151	↑ ↓
	120	620	88	12900	147	
	160	800	113	16600	147	
	190	940	138	19600	142	
	200	1050	149	20600	138	

Notes:

1 Normal tolerance $\pm 10\%$ due to factors including distribution type, LED bin variance, driver variance, and ambient temperatures.

2 Performance codes available in two ranges for adjustable output as shown in performance data tables. Output set at factory to specified performance code.



ARIETA® 13 Architectural LED Area Luminaire AR13 N-Series Specification Data Sheet

BUG Ratings: 3000K (30K)

All data nominal. IES files for all CCTs are available at www.leotek.com.

Product & LED Code	Output Code	Type 2	Type 3	Type 4	Type 5	Auto Front Row
		BUG Rating	BUG Rating	BUG Rating	BUG Rating	BUG Rating
AR13 48N	030	B1-U0-G1	B1-U0-G1	B1-U0-G1	B2-U0-G0	B1-U0-G1
	040	B1-U0-G1	B1-U0-G1	B1-U0-G1	B2-U0-G1	B1-U0-G1
	055	B1-U0-G1	B1-U0-G1	B2-U0-G1	B3-U0-G1	B2-U0-G1
	080	B1-U0-G1	B2-U0-G2	B2-U0-G2	B3-U0-G1	B2-U0-G2
AR13 48N	100	B2-U0-G2	B2-U0-G2	B2-U0-G2	B3-U0-G2	B2-U0-G2
	120	B2-U0-G2	B2-U0-G2	B3-U0-G3	B3-U0-G2	B3-U0-G2
	150	B3-U0-G2	B3-U0-G3	B3-U0-G3	B4-U0-G2	B3-U0-G3
	170	B3-U0-G2	B3-U0-G3	B3-U0-G3	B4-U0-G2	B3-U0-G3
	190	B3-U0-G3	B3-U0-G3	B3-U0-G3	B4-U0-G2	B3-U0-G3

BUG Ratings: 4000K (40K) and 5000K (50K)

All data nominal. IES files are available at leotek.com.

Product & LED Code	Output Code	Type 2	Type 3	Type 4	Type 5	Auto Front Row
		BUG Rating	BUG Rating	BUG Rating	BUG Rating	BUG Rating
AR13 48N	030	B1-U0-G1	B1-U0-G1	B1-U0-G1	B2-U0-G1	B1-U0-G1
	040	B1-U0-G1	B1-U0-G1	B1-U0-G1	B2-U0-G1	B1-U0-G1
	060	B1-U0-G1	B1-U0-G1	B2-U0-G1	B3-U0-G1	B1-U0-G1
	080	B2-U0-G1	B2-U0-G2	B2-U0-G2	B3-U0-G1	B2-U0-G1
AR13 48N	100	B2-U0-G2	B2-U0-G2	B2-U0-G2	B3-U0-G2	B2-U0-G2
	120	B3-U0-G2	B3-U0-G3	B3-U0-G3	B4-U0-G2	B2-U0-G2
	160	B3-U0-G3	B3-U0-G3	B3-U0-G3	B4-U0-G2	B3-U0-G3
	190	B3-U0-G3	B3-U0-G3	B3-U0-G3	B4-U0-G2	B3-U0-G3
	200	B3-U0-G3	B3-U0-G3	B3-U0-G3	B4-U0-G2	B3-U0-G3

Notes:

1 Normal tolerance $\pm 10\%$ due to factors including distribution type, LED bin variance, driver variance, and ambient temperatures.

2 Performance codes available in two ranges for adjustable output as shown in performance data tables. Output set at factory to specified performance code.



ARIETA® 13 Architectural LED Area Luminaire AR13 N-Series Specification Data Sheet

Motion Sensor (Optional) Specifications

Description

Digital passive infrared luminaire integrated outdoor occupancy sensor provides high/low/off control based on motion detection. Initial setup and subsequent sensor adjustments are made using a handheld configuration tool. PCR option is required for On/Off control using light detection.

Operation

Standard factory setting will dim the luminaire to 50% until motion is sensed and then it will power to 100%. When motion is not detected for five minutes, the luminaire will dim back to 50%. Ramp up and fade down times are adjustable, but initially set to NONE. The percent dimming and time durations may be field adjusted as required using FSIR-100 configuration tool. FSIR-100 user guide available at: www.wattstopper.com.

Optical System

Multi-cell, multi-tier Fresnel lens with a 360 degree view detects unobstructed motion within one mounting height, up to 20 ft. maximum (MSL3) or 40 ft. maximum (MSL7). Consult factory for higher mounting height requirements.

Finish

Sensor exterior ring and lens are white polycarbonate, UV and impact resistant.

Listings/Ratings

Sensor is TUV, UL and cUL listed, IP66 rated and CE compliant.

Warranty

5-year limited warranty on luminaires and components with a motion sensor.

Motion Sensor (Optional) Data

MSL3 Lens Dimensions

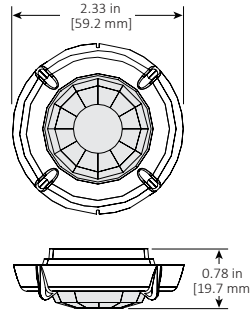

MSL3 Lens Coverage Top View

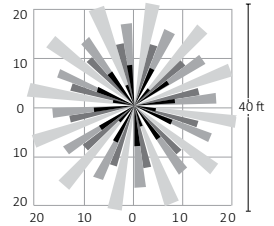

MSL3 Lens Coverage Side View

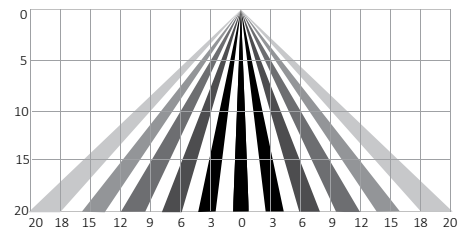

MSL7 Lens Dimensions

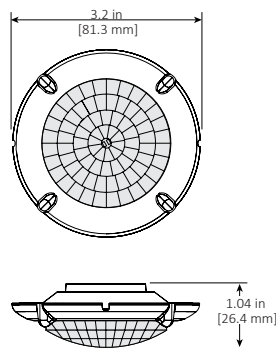

MSL7 Lens Coverage Top View

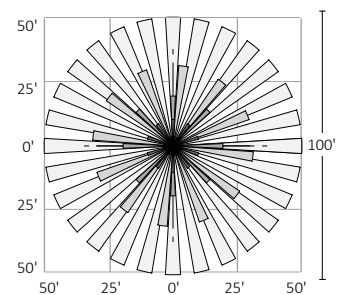

MSL7 Lens Coverage Side View

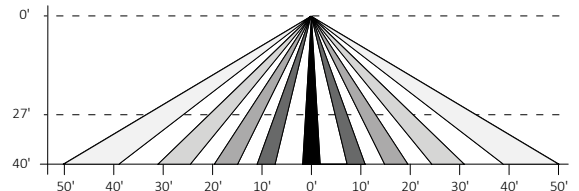



ARIETA® 13 Architectural LED Area Luminaire AR13 N-Series Specification Data Sheet

**Pole Mount Drilling Dimensions
for New Construction**
For more details, consult
the Arieta Installation Guide

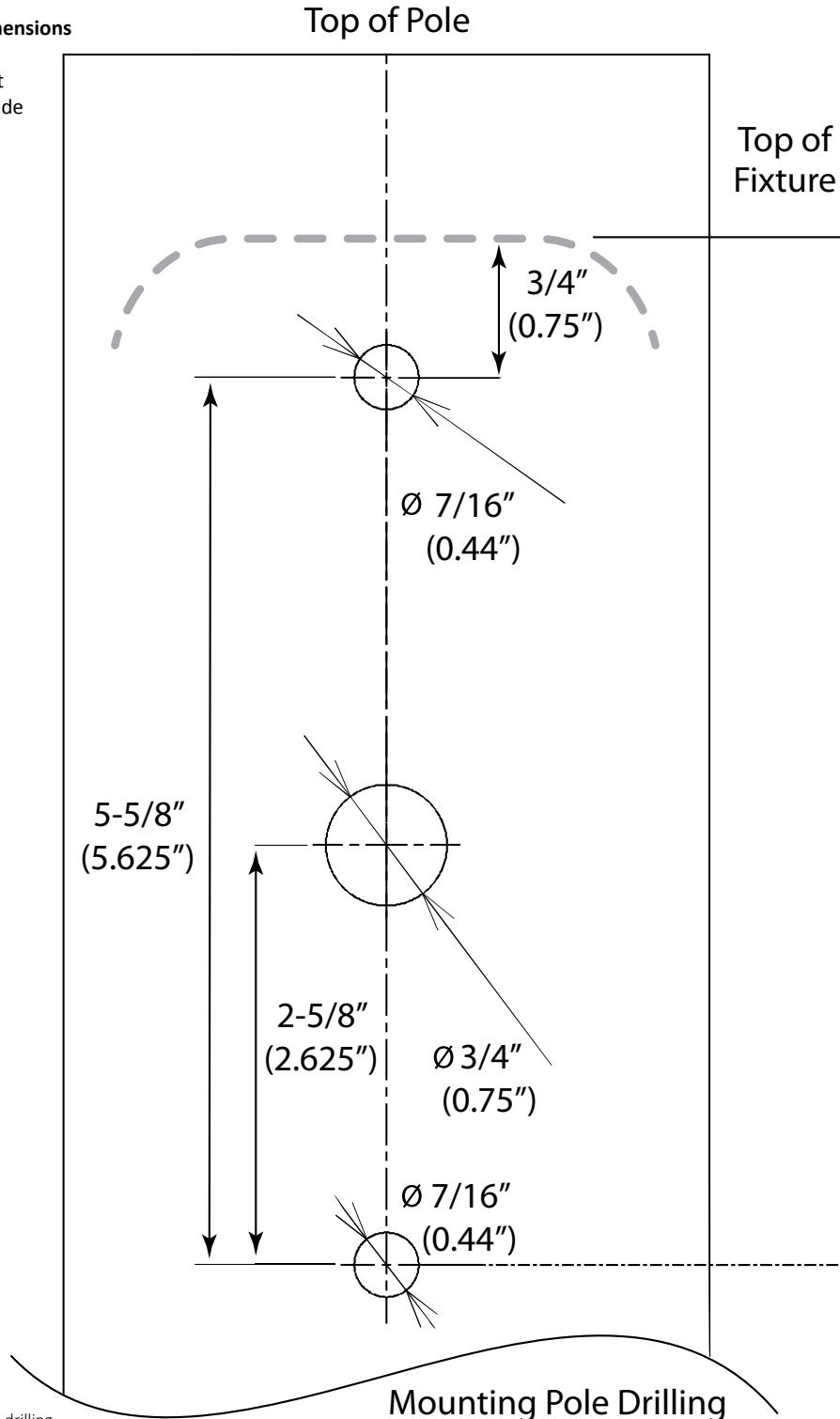

**Mounting Pole Drilling
Dimensions for New Construction**

If printing this page to be used as a drilling template, for best results update printer settings from: "Fit to Page" to "Actual Size".



Proj: City of Rogers - Territorial Park - LS952-4334-3

Type: SOLAR
CLEAR BLUE SOLAR PACKAGE



HiKu6 Mono PERC
395 W ~ 420 W
CS6R-395 | 400 | 405 | 410 | 415 | 420MS

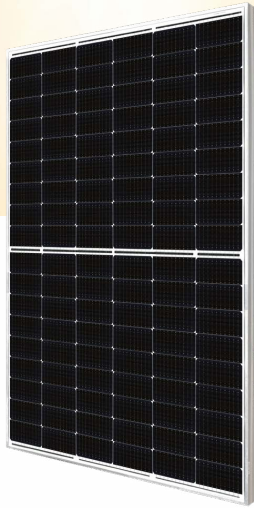

MORE POWER

- Module power up to 420 W
Module efficiency up to 21.5 %
- Lower LCOE & system cost
- Comprehensive LID / LeTID mitigation technology, up to 50% lower degradation
- Better shading tolerance

MORE RELIABLE

- Minimizes micro-crack impacts
- Heavy snow load up to 5400 Pa, wind load up to 2400 Pa*

*Black frame product can be provided upon request.

12 Years Enhanced Product Warranty on Materials and Workmanship*

25 Years Linear Power Performance Warranty*

1st year power degradation no more than 2%
Subsequent annual power degradation no more than 0.55%

*According to the applicable Canadian Solar Limited Warranty Statement.

MANAGEMENT SYSTEM CERTIFICATES*

ISO 9001:2015 / Quality management system
ISO 14001:2015 / Standards for environmental management system
ISO 45001: 2018 / International standards for occupational health & safety
IEC62941: 2019 / Photovoltaic module manufacturing quality system

PRODUCT CERTIFICATES*

IEC 61215 / IEC 61730 / CE / INMETRO / MCS / UKCA
UL 61730 / IEC 61701 / IEC 62716 / IEC 60068-2-68
UNI 9177 Reaction to Fire: Class 1 / Take-e-way



* The specific certificates applicable to different module types and markets will vary, and therefore not all of the certifications listed herein will simultaneously apply to the products you order or use. Please contact your local Canadian Solar sales representative to confirm the specific certificates available for your Product and applicable in the regions in which the products will be used.

CSI Solar Co., Ltd. is committed to providing high quality solar photovoltaic modules, solar energy and battery storage solutions to customers. The company was recognized as the No. 1 module supplier for quality and performance/price ratio in the IHS Module Customer Insight Survey. Over the past 20 years, it has successfully delivered over 82 GW of premium-quality solar modules across the world.

* For detailed information, please refer to the Installation Manual.

CSI Solar Co., Ltd.
199 Lushan Road, SND, Suzhou, Jiangsu, China, 215129, www.csisolar.com, support@csisolar.com



ENGINEERING DRAWING (mm)

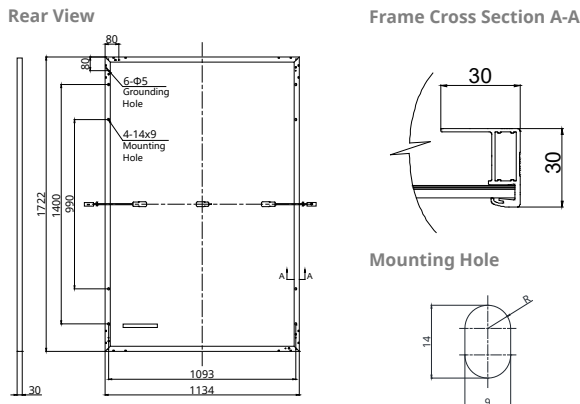

CS6R-405MS / I-V CURVES

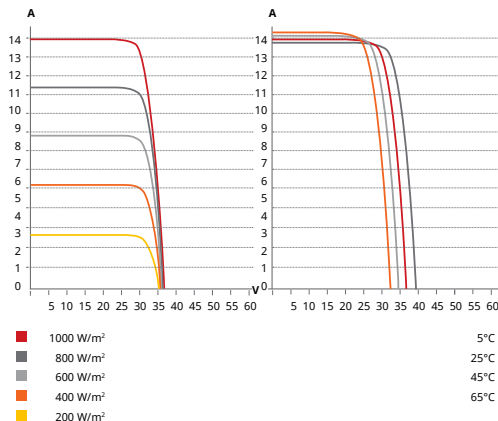

ELECTRICAL DATA | STC*

CS6R	395MS	400MS	405MS	410MS	415MS	420MS
Nominal Max. Power (Pmax)	395 W	400 W	405 W	410 W	415 W	420 W
Opt. Operating Voltage (Vmp)	30.6 V	30.8 V	31.0 V	31.2 V	31.4 V	31.6 V
Opt. Operating Current (Imp)	12.91 A	12.99 A	13.07 A	13.15 A	13.23 A	13.31 A
Open Circuit Voltage (Voc)	36.6 V	36.8 V	37.0 V	37.2 V	37.4 V	37.6 V
Short Circuit Current (Isc)	13.77 A	13.85 A	13.93 A	14.01 A	14.09 A	14.17 A
Module Efficiency	20.2%	20.5%	20.7%	21.0%	21.3%	21.5%
Operating Temperature	-40°C ~ +85°C					
Max. System Voltage	1500V (IEC/UL) or 1000V (IEC/UL)					
Module Fire Performance	TYPE 1 (UL 61730 1500V) or TYPE 2 (UL 61730 1000V) or CLASS C (IEC 61730)					
Max. Series Fuse Rating	25 A					
Application Classification	Class A					
Power Tolerance	0 ~ + 10 W					

* Under Standard Test Conditions (STC) of irradiance of 1000 W/m², spectrum AM 1.5 and cell temperature of 25°C.

MECHANICAL DATA

Specification	Data
Cell Type	Mono-crystalline
Cell Arrangement	108 [2 X (9 X 6)]
Dimensions	1722 × 1134 × 30 mm (67.8 × 44.6 × 1.18 in)
Weight	21.3 kg (47.0 lbs)
Front Cover	3.2 mm tempered glass with anti-reflective coating
Frame	Anodized aluminium alloy,
J-Box	IP68, 3 bypass diodes
Cable	4 mm² (IEC), 12 AWG (UL)
Connector	T6 or MC4 or MC4-EVO2 or MC4-EVO2A
Cable Length (Including Connector)	Portrait: 410 mm (16.1 in) (+) / 290 mm (11.4 in) (-); landscape: 1100 mm (43.3 in)*
Per Pallet	35 pieces
Per Container (40' HQ)	910 pieces

* For detailed information, please contact your local Canadian Solar sales and technical representatives.

ELECTRICAL DATA | NMOT*

CS6R	395MS	400MS	405MS	410MS	415MS	420MS
Nominal Max. Power (Pmax)	296 W	300 W	304 W	307 W	311 W	315 W
Opt. Operating Voltage (Vmp)	28.7 V	28.9 V	29.1 V	29.2 V	29.4 V	29.6 V
Opt. Operating Current (Imp)	10.33 A	10.39 A	10.45 A	10.52 A	10.58 A	10.65 A
Open Circuit Voltage (Voc)	34.6 V	34.8 V	35.0 V	35.1 V	35.3 V	35.5 V
Short Circuit Current (Isc)	11.09 A	11.15 A	11.21 A	11.28 A	11.34 A	11.41 A

* Under Nominal Module Operating Temperature (NMOT), irradiance of 800 W/m² spectrum AM 1.5, ambient temperature 20°C, wind speed 1 m/s.

TEMPERATURE CHARACTERISTICS

Specification	Data
Temperature Coefficient (Pmax)	-0.34 % / °C
Temperature Coefficient (Voc)	-0.26 % / °C
Temperature Coefficient (Isc)	0.05 % / °C
Nominal Module Operating Temperature	41 ± 3°C

PARTNER SECTION



* The specifications and key features contained in this datasheet may deviate slightly from our actual products due to the on-going innovation and product enhancement. CSI Solar Co., Ltd. reserves the right to make necessary adjustment to the information described herein at any time without further notice.

Please be kindly advised that PV modules should be handled and installed by qualified people who have professional skills and please carefully read the safety and installation instructions before using our PV modules.

CSI Solar Co., Ltd.

199 Lushan Road, SND, Suzhou, Jiangsu, China, 215129, www.csisolar.com, support@csisolar.com



Smart Off-Grid Controller

For Solar & Hybrid Powered Systems

Delivers power anywhere, anytime with remote operations of mission critical applications. Commercial, business, and industrial systems will now have unparalleled:

- > Energy Forecasting & Management
- > Troubleshooting & Remediation



Clear Blue's industry leading Smart Off-Grid Controller with our Illumience Management Software and Service provides energy generation, storage management and load control for systems needing:



Maximum Uptime

Our predictive analytics, weather forecasting and individual load control enables management for maximum uptime.



Long Life

Our Dynamic Charging algorithm uniquely focus' on battery charging with the unpredictable nature of off-grid solar energy.



Maintenance & Easy Installation

More than 80% of all issues are managed and eliminated through our remote management service. Installers and customers get peace of mind through our commissioning & provisioning services to ensure you get it right the first time, every time.

Delivering on the Promise of Power
www.clearbluetechnologies.com

Technical Support:+1.647.748.4822 ext.300
support@clearbluetechnologies.com



Smart Off-Grid Controller

Technical Data

Port Ratings		
Power I/O Rating	Voltage and Power	Current
Battery Input/Output	18-32V	Max 30A
Nominal PV Power	840W	Max 30A
Solar 1, Solar 2 Input	52V Maximum	Max 15A each
Hybrid I/O Port Input	42V	Max 30A
Hybrid I/O Port Output	18-32V	Max 30A
Load 1, Load 2 Output	18-32V	Max 20A Each Combined 30A

Signal I/O Rating		
M+ Output	Software Configurable (default 12V)	Maximum 1A
M1 Input/M2 Input	9-32V	N/A
D1 Output/D2 Output	Analog: 0-5V or 0-10V with protection up to 52V	4.5mA source; 50mA sink
Auxiliary Port Output	Software controlled internal switch to battery negative	250mW

Smart Off-Grid Cloud Management & Service	
Illumience Management (Cloud Based)	All settings remotely managed by the Illumience cloud service including remote monitoring, troubleshooting and remote software upgrade.
Management Benefits	Remote control, >50 customizable parameters, customizable alarms, weather & energy forecasting, remote resting & remediation tools, group management, battery state of charge and health.
Service Support	Clear Blue service team monitors and manages sites on behalf of customer.
Security	All data between devices and the Cloud are encrypted for security purposes.

Communications	
Built In Communications	Cellular, mesh or WiFi.

Warranty	
Warranty	5 year warranty



Smart Off-Grid Controller

Technical Data

Features	
Protection	Reverse polarity, battery overcharge, over discharge and temperature compensation, I/O overload protection, short circuit and low voltage disconnect, overvoltage protection and transient voltage protection across all power I/O's. High availability features - variable short circuit multi-try and variable surge current management.
Dimming Control	Dimming controls are 0-10V, 0-5V, PWM signal and PWM power with remote frequency adjustable from 100kHz to 10kHz.
Motion Detection	Motion detection can be enabled in all four adjustable light profile stages. Real time event settings combined with motion detection ensures the right amount of light at the right time while optimizing system availability and cycle life of the system. Includes output protection, short circuit and overload.
Smart Battery Charge Profile	Four stage eight parameter, remote software configurable charge profile designed specifically for solar charging. It can be adjustable to all battery chemistries using Clear Blue's dynamic charging complete with fully customizable temperature compensation.
Remote Software Update	New features delivered to all devices via remote software download.
High Availability Internal Bypass for L1 and or L2 (optional)	Eliminates need for external bypass. Designed for mission critical applications. Feature ensures always on loads remain on during software download or software failure. Includes overload, short circuit, LVD, LVR.
M+ Output	Power signal that can be used to power small signal loads. DCDC voltage regulated output that is software configurable.
M1/M2 Input	Input signal typically used for external sensors such as door sensors, motion sensor etc.
D1/D2 Output	Output signal used for dimming. Output analog or digital PWM (software configurable).
Battery Type	Configurable for all lead acid, lithium batteries and other battery chemistries.

Physical & Environmental	
Connectors	Toolless colour coded wire push-in connectors make for easy, foolproof installation. Molex and RJ11 connectors for temperature.
Dimensions (L x W x H)	200 mm x 120 mm x 62.5 mm
Weight	0.6 kg
Ambient Temperature	-30°C to 60°C
Controller Power Consumption	2W Max

Certifications	
Health & Safety	IEC/UL/CSA601010-1, CSA C22.2 No.1071 and UL50E, TUV certified
EMC (EUDirective 2014/30/EU)	ETSI EN301 489-1 V2.1.1, ETSI EN 301 489-17 V3.1.1 (2017-02) & ETSI EN 301 489-52 V1.1.0



Smart Off-Grid Controller

Technical Data

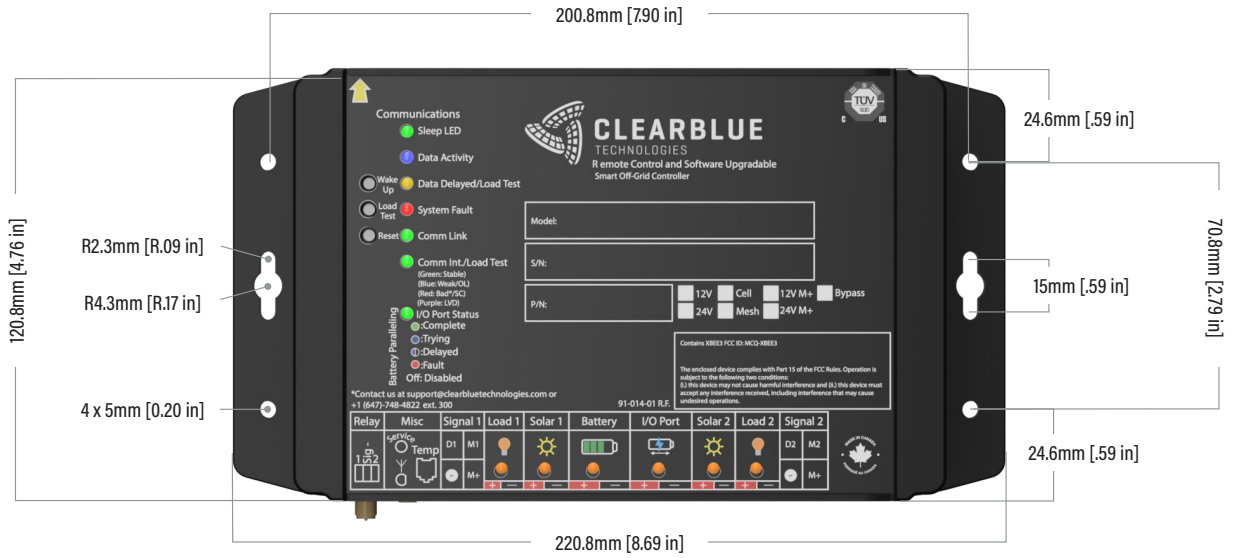

Mounting Option A

Mounting Option B



Delivering on the Promise of Power
www.clearbluetechnologies.com

Technical Support:+1.647.748.4822 ext.300
support@clearbluetechnologies.com



Proj: City of Rogers - Territorial Park - LS952-4334-3

Type: SOLAR
CLEAR BLUE SOLAR PACKAGE



150W

DC-AC Inverter
Pure Sine Wave

Model	PST-150-12 12 VDC- 120 VAC
	PST-150-24 24 VDC- 120 VAC

Design Features

- High efficiency
- 2x surge
- Temperature controlled cooling fan – reduces energy consumption
- Low RF emissions
- Wide operating DC input range: 10.5 - 16.5 VDC / 21.0 - 33.0 VDC
- LED indicators for power and protections
- Low idle power draw
- Two AC outlets
- Commercial grade design suitable for heavy duty loads, long periods of continuous operation & for emergency back up
- UPC – Universal Protection Circuit: low voltage, over voltage, over temperature, over load and short circuit.
- Detachable cable with 12V plug adapter
- Detachable cable with battery clamps
- Safety certified to UL & CSA standards, FCC compliant

2 YEAR LIMITED WARRANTY



	MODEL NO.	PST-150-12	PST-150-24
OUTPUT	OUTPUT VOLTAGE	120 VAC ± 3%	120 VAC ± 3%
	MAXIMUM OUTPUT CURRENT	1.25A	1.25A
	OUTPUT FREQUENCY	60 Hz ± 1%	60 Hz ± 1%
	TYPE OF OUTPUT WAVEFORM	Pure Sine Wave	Pure Sine Wave
	TOTAL HARMONIC DISTORTION OF OUTPUT WAVEFORM	< 3%	< 3%
	CONTINUOUS OUTPUT POWER (At Power Factor = 1)	150 Watts	150 Watts
	SURGE OUTPUT POWER	300 Watts (< 8 ms)	300 Watts (< 8 ms)
	PEAK EFFICIENCY	87%	89%
INPUT	AC OUTPUT CONNECTIONS	2 x NEMA5-15R Outlets	2 x NEMA5-15R Outlets
	NOMINAL DC INPUT VOLTAGE	12V	24V
	DC INPUT VOLTAGE RANGE	10.5 - 16.5 VDC	21 - 33 VDC
	MAXIMUM INPUT CURRENT	20A	10A
DISPLAY	DC INPUT CURRENT AT NO LOAD	< 500 mA	< 400 mA
	DC INPUT CONNECTIONS	Tubular Type Screw Down Terminals	Tubular Type Screw Down Terminals
PROTECTIONS	LED	Power, Abnormal	Power, Abnormal
	LOW DC INPUT VOLTAGE ALARM	10.5V	21V
	LOW DC INPUT VOLTAGE SHUTDOWN	10V ; Auto reset at 11.5V	20V; Auto reset at 23V
	HIGH DC INPUT VOLTAGE SHUTDOWN	16.5V ; Auto reset at < 16.5V	33V ; Auto reset at < 33V
	SHORT CIRCUIT SHUTDOWN	When output voltage drops to 80VAC for 5 sec	
	OVERLOAD SHUTDOWN	At overload of 110% to 115% for 2 to 2.5 sec	
	GROUND FAULT SHUTDOWN	Yes (Load should be powered using power cord with NEMA5-15P plug)	
	OVER TEMPERATURE SHUTDOWN	At internal hot spot Temp of 95°C ; Auto reset at 70°C	
	REVERSE POLARITY ON DC INPUT SIDE	Internal DC side fuse will blow	
	INTERNAL DC SIDE FUSE	Automotive Blade Type: 32V; Interrupting Capacity 1000A @ 23V; Littell Fuse Type "ATO", 287 Series 20A / 32V	
COOLING	FORCED AIR COOLING	Temperature Controlled Fan - ON at internal hot spot ≥ 48°C ; OFF at 42°C	
COMPLIANCE	SAFETY	Intertek - ETL Listed. Conforms to ANSI/UL Standard 60950-1; Certified to CSA STD. C22-2 No. 60950-1.	
	EMI / EMC	FCC Part 15(B), Class B	
ENVIRONMENT	OPERATING TEMPERATURE RANGE	-20°C to 40°C / -4°F to 104°F	-20°C to 40°C / -4°F to 104°F
DIMENSIONS	(W x D x H), MM	155 x 211 x 65.5	155 x 211 x 65.5
	(W x D x H), INCHES	6.1 x 8.31 x 2.58	6.1 x 8.31 x 2.58
WEIGHT	KG	1.27	1.27
	LBS	2.8	2.8

NOTE: Specifications are subject to change without notice

12001-PST-150-12-24-0216

To view a full selection of Samlex products visit our website at www.samlexamerica.com or contact us: 1-800-561-5885 or sales@samlexamerica.com



105 AH LITHIUM-ION BATTERY SPECIFICATIONS

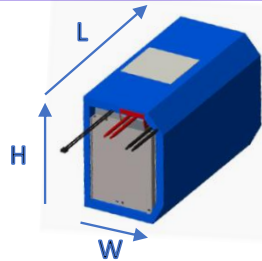

Item	Specification	Comments
Product Dimensions	(L x W x H) 390*161*213 mm	
Weight	<21 Kg	
Nominal Voltage	25.6 V	Cell 3.2V
Max. Voltage	29.2 V	Cell 3.65V
Min. Voltage	20 V	Cell 2.5V
Nominal Capacity	105 Ah	@ 0.5C
Nominal Energy Content	≥2688 Wh	@ 0.5C
Discharge Operation Max Current (10s, 25°C, SOC 50%, BOL)	200A	200 Per 1 cell
Charge Operation Max Current (10s, 25°C, SOC 50%, BOL)	200A	200 Per 1 cell
Continuous Discharge Operation Max Current (25°C, SOC 50%, BOL)	80A	80 Per 1 cell
Continuous Charge Operation Max Current (25°C, SOC 50%, BOL)	52.5A	52.5 Per 1 cell
Operating Temperature Range	Charging	0°C ~ 55°C
	Discharging	-20°C ~ 55°C
Storage Temperature	Short Term (within 1 month)	-20°C ~ 45°C
	Long Term (within 1 year)	0°C ~ 35°C
IP Grade	IP44	
Cycle Life (25°C, 0.5C charge, 1C discharge, DOD 100%)	>3500	
Protections	Over Charge, Over Discharge, Over Current, Over Temperature, Balance Function	



Handling Precautions and Prohibitions of Lithium-Ion Battery

Before using the battery, be sure to read the battery handling precautions.

Improper handling of lithium ion battery may cause leakage, heat, smoke, an explosion or fire. This could cause deterioration of performance or failure.

Precautions:

- Don't throw the battery into a fire or leave the battery near a fire/heat source
- Don't heat an part of the battery with heating object such as a soldering iron.
- Don't solder anything on the battery directly.
- Don't immerse, throw, and wet the battery in water/seawater.
- Don't expose the battery to a water splashing condition.
- Don't store metallic objects such as keys or screwdriver near the cell.
- Don't short circuit (+) and (-) terminals with metallic object intentionally.
- Don't step on the battery and throw or drop the battery on the hard floor.
- Don't use the battery if it is dropped by accident.
- Don't disassemble the battery or modify the battery design including electric circuit.
- Don't use seriously scar or deform the battery .
- Don't hit the battery with heavy objects such as a hammer or heavy weights.
- Don't put the battery into a microwave oven, dryer, or a high-pressure container
- Don't expose the heavy humidity condition.
- If the battery needs to be stored for a long period, the battery should be removed from the application and stored in a proper place under room temperature conditions.
- No other items can be stacked on the battery pack.
- Flammable and explosive items should not be placed near the packaging box and kept at a distance of more than 2m.
- While the battery is charged, used and stored, keep it away from object materials with static charge.

Warning:

- Stop using the battery if it becomes abnormally hot, develops an odor, becomes discolored, becomes deformed, or develops any other abnormal conditions during use, charge, discharge, or storage.
- Keep away from fire or hot heat sources immediately when a leakage or foul odors are detected. If liquid leaks onto your skin or cloths, wash it out with plenty of fresh water immediately.
- If liquid leaks from the battery and gets into your eyes, don't rub your eyes.
- Wash your eyes out with plenty of clean water and seek medical attention immediately.
- If the terminals of the battery become dirty, wipe them with a dry cloth before using the battery module.



Proj: City of Rogers - Territorial Park - LS952-4334-3

Type: SOLAR
CLEAR BLUE SOLAR PACKAGE



Installation Instructions

- Before installing and removing the battery from application, be sure to read the application's user manual.
- Check whether the appearance of the battery pack is damaged or leaking before installation
- If the battery pack is deformed or smells before installation, it is forbidden to use the battery pack to avoid safety accidents.
- Measure whether the open circuit voltage of the battery is within the normal range.
- Pay attention that the positive and negative poles of the battery pack cannot be reversed.



STAFF REPORT

Meeting Date: December 11, 2025

**ROGERS PARKS AND
RECREATION ADVISORY
COMMISSION**

Agenda Item: 6.9

Subject: 2025 Work Plan

Prepared By: Mike Bauer, Parks & Recreation Director

Overview / Background / Analysis

The Parks and Recreation Advisory Commission recommends a work plan to guide yearly staff activities. This list is for the more significant initiatives, which usually involve many hours of planning or construction.

Local Option Sales Tax Projects

Indoor Turf Facility (Complete \$13.2M)

Future Recreation Facility Site Improvements (Complete \$2M)

South Community Park Athletic Improvements (Complete, Estimated \$4M)

Splash Pad (Complete \$1.5M)

I-94 Ped Crossing (On Hold, No State Bonding Money Available)

144 Tunnel (On Hold: Cost of the project escalated beyond means)

Trails:

SDLR-137th (Pending Design)

Hassan Elementary to Marie Ave (Complete)

Henrys Woods to SDLR

Cambria to 147th

Brocton Meadow to 144

Edgewater to Willindale

City Improvements to School Pool (Pending ISD 728 Actions may be past the date of bonding availability)

Staff Recommendation

Financial Impact:

Source Fund:

Budgeted?

Supporting Documentation

A. 2025 Work Plan

2025 Work Plan			
Category	Project	Status	Next Steps
Trails	Territorial View Estates	Planning	County is reviewing intersection alignment
Trails	RMS/RHS Tunnel (LOST)	Hold	Engineering reached out to see if ISD 728 could participate in a Safe Routes to School grant and ISD 728 does not have dollars for this in the current 10 year plan for the mandatory local match.
Trails	I-94 Pedestrians Crossing(LOST)	Hold	
Trails	Brockton Lane to Wellstead Drive (FMP)	Design	Will be part of the SDLR reconstruct 2026
Trails	SDLR -137th (LOST)Rachel Development	Partial Completion.	Next steps: RFP for design and right of way acquisition.
Facility	Event Center Donor Recognition Overall	Design	Will be using the scheduling software platform.
Park/Facility	Hennepin County Youth Sports Grant Spring Playground	TBD	
Park/Facility	Hennepin County Youth Sports Grant Fall Capital	Started	City Council has recommended applying for the Ice Expansion.
Park	Cambria Hills Park and Trail Development		Recommend Moving to 2026
Facility	Senior Center Programming Locations		Due to some changes with MN Housing the closing is now scheduled to happen on September 29
Parks	RHS Softball Field Request for Hassan Hills	Hold Pending Funding	Staff Recommends discussing a change in strategy for this field.
Parks	Determine Playground Replacement Priority		Tonights Agenda
Parks	Final Design of Territorial Park		Sunnyside for 2026
Parks	NCP Build out Design		Working on RFP with Anderson Engineering.
Parks	Select Parks for Hard Court and Pavilions		Tonights Agenda
Parks	Crow River Heights		Staff contacted Flagship Recreation to move this project forward. (No Response)
Parks	Cowley Lake House Removal		
Parks	Tree inventory/management plan www.mntreesource.com		Public Works Superintendent is reaching out to vendors for proposals.
Parks	Fox Creek West Playground Replacement		Complete
Parks	Brookside Meadows Playground Replacement		Complete
Park/Facility	SCP FFE Purchase		Complete
Park/Facility	SCP Ribbon Cutting		Set Date Spring 2026
Park/Facility	SCP Concessions Operations		
Park/Facility	Rink Attendant Position???		
Facility	Indoor Turf Facility	Allocation	
Facility	Indoor Turf Facility	Policies/Procedures	Ongoing
Facility	Indoor Turf Facility	FFE Purchases	Ongoing
Facility	Indoor Playground	Waiting For Delivery.	Complete
Facility	Indoor Turf Facility	Staffing	Ongoing
Facility	Indoor Turf Facility	Ribbon Cutting/Grand Opening	Complete
Recreation	Programming Lists and Policies		
Trails	Plan for trails at SCP connecting to Astermills		Complete
	Plan for 2026 information gathering/strategies for master plan update		
	Complete		
	Change from last report		
	On Hold		



STAFF REPORT
**ROGERS PARKS AND
RECREATION ADVISORY
COMMISSION**

Meeting Date: December 11, 2025

Agenda Item: 8.1

Subject: Correspondence and Staff Report
Prepared By:

Overview / Background / Analysis

Staff Recommendation

Financial Impact:

Source Fund:

Budgeted?

Supporting Documentation

- A. Coorispondence
- B. Flyer - Celebrating Our New Trees Together (1)
- C. Park and Rec Staff Update



From: Ryan Wilson
Sent: Friday, October 24, 2025 2:40 PM
To: Mike Bauer <mbauer@rogersmn.gov>; Ashly Wilson
Subject: Re: Park Behind House - Rachael Drive , Rogers

Hi Mike,

The park seems to be coming along nicely. We do have a couple of things that are concerning us though. In the meetings there were concerns brought up by not only the houses on this street, but also by residents of the neighborhood about privacy and it was assured to us that it was being addressed and would be taken care of by planting trees and bushes. Well, it appears that we have a very different definition of what privacy means. What was planted seems to be purely for aesthetics. They provide zero privacy. Especially since they built the park up so high. Even adding a privacy fence won't even provide any cover. Additionally, the tall tower looks directly into our windows! I don't know if this falls on the city or the park builder, but something needs to be done. Let me know what thoughts or ideas you have.

Also, I have concerns about our yard. In the pictures there is a pink stake (marked by the red line) that I understand is our property line. My concern is the transition from the sod of our yard to the seed that was put down by the park prep. I'd like to have a uniform yard and want to know what can be done for this. If the seed grows in and I won't notice the difference that is fine, but I'd like to at least have someone look at it and let me know.

Have a good weekend.

Regards,

Ryan and Ashly Wilson
From: Mike Bauer <mbauer@rogersmn.gov>
Sent: Tuesday, November 11, 2025 4:35 PM
To: Ryan Wilson, Ashly Wilson
Subject: RE: Park Behind House - Rachael Drive , Rogers

Hi Ryan and Ashley,

I wanted to let you know that I'm waiting on a final report from our project designer to confirm that everything in the park was built according to the approved plans. Once I receive that information, I'll be sure to reach back out and share an update with you.

I'll be out on medical leave starting tomorrow and working remotely as I'm able, so there may be a short delay in follow-up. I appreciate your patience and understanding in the meantime.

Thank you,

Mike Bauer

On Wed, Nov 12, 2025, 2:38 PM Ryan Wilson wrote:

Hi Mike,

Thank you for the update. I'm sure the project designer will say that the park was done to plan, but what was never mentioned was the height they were going to raise the property it sits on. It was raised so high that it sits above the "privacy trees" and even if we were to install a privacy fence park attendees would have no issue seeing over it. It just feels like we are in a fishbowl. I don't know what the answer is, but I hope we can all think of something.

That said, health is most important. I hope your medical leave goes as well as possible and we look forward to hearing from you whenever you get the chance.

Thank you,

Ryan and Ashly

Just chiming in behind Ryan to add the reminder that our HOA doesn't even allow for privacy fences as the rules stand, so we seem to really just be stuck. Don't get us wrong, we definitely feel that the park brings certain value to our home and lives, we just also want some privacy when in our backyard and not feeling like every conversation or movement we make is being heard or watched by 20 people at a time. Additionally, as any parent should be, we have some concerns about the safety of our young toddler. The park has already been very busy even with the colder weather and we worry how much busier it will be come warm weather.

Also, I'm not sure if it can be changed... but that telescope on top of the large fort structure points right at our home. Can they put that on the opposite side so it looks at the pond??

I appreciate you hearing our continued concerns and working with us to find any possible solutions so the park can be enjoyed by all, while still feeling though our privacy is respected. We wish you well and that you are allowed the time to take care of yourself in this season of life.

Thank you.

Hello Mike!

This is Anatoliy Tkach at XXXXX Rachael Dr, Rogers, MN Skye Meadows I would like to address our concerns regarding the new park.

When we first heard about the new park being built we thought it would be built somewhere in the middle of the open space. When we found out that the playground will be built right at the edge of our backyard we addressed our concerns about privacy and the loud noise. I wrote an email before the park began to be built. Well it seems like none of our concerns were addressed and the city just went ahead with the plans without doing anything to fix the issue of privacy and noise.

My wife and I have two small children, they take a few naps daily, with the noise coming from the park we have a hard time because they hear the noise coming from the park and it's hard for the kids to fall asleep.

Also on Friday November 14, 2025 (last weekend) I called the police at 11:00 pm because there were 4-5 teenagers playing basketball with the flashlights and later sat at the playground climbing the playground house and laughing, yelling and making noise right in our back yard.

Also people coming with their dogs, not pickup the poop after their dogs. The park is crowded during peak hours and we can't enjoy the park as residents of Skye meadows because there are people coming from all over Rogers to use the park. So the park does very little good for us as residents who have to put up with the noise and privacy issues.

Because the park is so close to our house we see people peeking through our windows while we are in our living room or kitchen. We went to have a look from the park looking into our house and indeed everything is visible. There is zero privacy! We have to keep our blinds shut day and night in order to have our privacy. I don't believe this is fair!

We love our home, but unfortunately due to The city of Rogers not taking in consideration our privacy and noise concerns we cannot enjoy our home as much as we did before the park was built.

My wife and I already talked about if the city of Rogers will continue to ignore our privacy and noise concerns we have no other choice but to sell the house and move somewhere else. It feels like the four houses which are bordering the park were left on our own to deal with these issues.

In conclusion, We ask the city of Rogers to come up with a quick solution to fix our privacy and noise concerns so we don't have to move out due to noise and privacy concerns.

The trees and bushes that were planted have done nothing to help with thr noise and privacy!
We would appreciate if the city can come up with a different plan!

Thank you!

From the Coorispondence in March 2025

Sent from my iPhone

Name: Anatoliy Tkach

Subject: Territorial park site plan

Territorial Park Site Plan Comments: My wife and I have many concerns.. to be honest we are against the idea of having a park in our backyard. When we purchased the home we we thought we will have

trees and wet land in our backyard. That's what was advertised by Lennar. Then we found out there will be a park so we became very concerned.

These are some of our concerns:

- 1) privacy , the trees will not provide sufficient privacy, what happens when there are no leaves?
- 2)safety for our two kids which are toddlers
- 3)Noise (too close to our home, our kids bedrooms are facing the park). Park Maintenance vehicles making noise.
- 4)strangers looking at our home
- 5) parks and wooded areas attract burglars
- 6)Leftover food attracts wild life, raccoons, etc
- 7)if there will be a public restroom too close to our house, the smell during the hot summers becomes unbearable/unpleasant
- 8)What is the safety plan? Police patrolling the park? What will be the curfew/quiet time hours?
- 9)Parks attract Teenagers smoking/drinking/loud
- 10) Our association only allows chain link fencing. This is not sufficient for privacy. Either the city comes up with a plan for privacy, or the association allows us, the residents to build a privacy fence of our choice that will ensure our full privacy all year round.

We are asking if the play areas can be moved further in and away from our lot line?

Since we have no choice but to agree on a park plan, we decided to go with plan 1. We hope it can be moved further in closer to the wooded area where it will not bother the neighbors.

Rope Play Equipment Selection: C - Unity SpinR

Park Layout Options: Park Layout Option 1

From: Ricardo Amaro

Sent: Tuesday, October 28, 2025 8:22 PM

To: Department - Administration - Info <info@rogersmn.gov>

Subject: Resident pricing for Fieldhouse

Hi,

I am reaching out to ask a question. Are residents from Otsego considered residents for Fieldhouse use rates?

Thanks in advance,

R. Amaro

From: Patrick A. Ruppe

Sent: Tuesday, November 11, 2025 3:25 PM

To: Mike Bauer <mbauer@rogersmn.gov>

Subject: Day spring park

Mike, good afternoon, My wife and I walk over in Day Spring park. We've notice that there has been dumping. Today we saw fresh yard waste an we also witnessed a resident of Day Spring neighborhood in his ATV with the same waste in the bed . When he saw us he turned around and went back to his house. I can provide the house number if needed. I don't have it on me at the moment.

From Resident:

The fox creek park trail doesn't have a single light pole in the area of the park or along the "Y" in the trail.

From: Mike Brain
Sent: Friday, November 28, 2025 9:25 PM
To: Mike Bauer <mbauer@rogersmn.gov>
Subject: Field house

Dear sir.

I am fully 100% behind the new field house. In my battle for standing behind it, I need some information about cost.

Does TruStone pay to have their name on it? TCO?

Thanks in advance. I'm getting beaten up! 🤪

Mike Brain
Rogers, MN
Hi Mike,

Thanks for reaching out and for standing behind the fieldhouse project – I really appreciate your support, especially when you're "getting beaten up" over it.

A quick overview of what the TruStone Center is and will be:

- Today:
 - o "TruStone Center" is the new name for the overall campus that includes the existing ice arena (formerly the Rogers Activity Center) and the HealthPartners Fieldhouse (new indoor turf facility).
- In the near future:
 - o TruStone Center will be the name for the full complex (ice 1, ice 2, fieldhouse + shared spaces)
 - o Our installers simply ran out of time this fall to get all of the exterior branding installed on the arena side. There are still additional signs and graphics planned that will visually tie the entire campus together so it feels like one unified TruStone Center rather than separate buildings. Those elements will be installed as weather and schedules allow.

On your main question:

- Yes, TruStone Financial is paying to have their name on the facility through a multi-year naming rights agreement that was approved by the City Council. That revenue helps offset costs to the city and taxpayers and supports capital funding for the facility.
- Similarly, HealthPartners is also a paying naming rights partner for the fieldhouse portion of the complex.
- There is no TCO naming agreement at this facility – that's a partner you might see at other regional sports complexes, but here it's TruStone (overall campus) and HealthPartners (fieldhouse) and Tria for ice 2. We are still in negotiations for ice 1 naming rights.

If you ever want more detail so you can feel fully equipped for those conversations, I'm happy to walk you through the structure in more depth.

Thanks again for the email and for being engaged in what's happening out here.

Best,

Parks and Recreation Director

Mike Bauer

Great Job setting up the White Christmas event at the Chanhassen.
Unfortunately, we already had tickets for the Black Friday afternoon show.
It was Great!

I didn't know that the group will get recognized as part of the introduction. You might tell them to wave their napkins to highlight their location in the playhouse.

I forgot it seats 500 people per show.

Thanks again for planning a great event.

Merry Christmas,

Dave Nei



Thank You, Rogers Rotary!

Celebrating 44 New Trees At South Community Park!



City of
ROGERS
Parks & Recreation



Staff Updates

Updates – Fall/Winter 2025

Learn to Skate

- Fall 2 Session runs Saturdays 10/25/25-10/13/25, skipping 2/8/25
- 110 participants this year vs 130 in 2024

Class	Participants	Revenue
Adult/Teen Class	1	\$72.00
Basic Skills 1	6	\$432.00
Basic Skills 2	5	\$360.00
Basic Skills 3	8	\$576.00
Basic Skills 4	2	\$144.00
Hockey 1	11	\$792.00
Hockey 2	2	\$144.00
Hockey 3	0	\$-
Hockey 4	1	\$72.00
Hockey Edge	1	\$72.00
Snowplow Sam 1	41	\$2,952.00
Snowplow Sam 2	19	\$1,368.00
Snowplow Sam 3	11	\$1,368.00
Snowplow Sam 4	2	\$144.00
Total	110	\$7,920.00

Halloween Carnival and Open Skate

- Sunday, 10/26/25
- Carnival 3:00-4:30pm, Open Skate 4:00-5:10pm
- Approximately 100 carnival attendees, on par with previous years
- 23 paid Open Skate admission, admission was free with a costume on, find a better way to track free admissions next year
- Community Ed supplied carnival games and prizes
- Busiest carnival time was 3:00-4:00pm, only had two attendees between 4:00-4:30pm
- Next year adjust carnival to end at 4:00pm

Daddy Daughter Dance

- Friday, November 7, 2025

- Sold all 150 seats, made \$1,164.67 in revenue
- Most successful dance to date, goes smoother every year
- Two major pros this year were making all tickets one price and having two active buffet lines for faster dinner service

Revenue		
Tickets	150 @ \$20/person	\$3,000.00
Total Revenue		\$3,000.00
Expenses		
DJ - Kidsdance		\$630.00
Catering - Center Cut	160 @ \$5/each	\$640.00
Dessert - Nothing Bundt Cake	13 doz @ \$30/doz	\$390.00
Supplies and Decor		\$175.33
Total Expenses		\$1,835.33
Difference		\$1,164.67



Winter Farmers Market

- Third Wednesday of the Month at the 21st Century Bank Event Center from 3:00-5:30pm
- First market was Wednesday, November 19th
- 14 vendors, approximately 40 attendees
- Brand new winter market, we are working to promote more

- Market Coordinator Kristen Scott took plenty of pictures at the first market that we will use for extra promotion for remaining markets



Holiday Tree Lighting Ceremony

- Friday, December 5, 2025 at the 21st Century Bank Event Center from 6:00-8:00pm
- Approximately 400-500 attendees, hard to estimate due to free open-house style even, but looked on par compared to previous years
- Letters to Santa station, letters could then be brought to Santa in the Great Hall or dropped off for Santa to bring back to the North Pole
- RHS DECA pop-up shop provided opportunity for attendees to purchase Rogers gear
- Rogers Lions Club did not attend to serve hot chocolate, cider, and cookies this year; we will reach out to see if they are interested in returning next year, otherwise we will provide those items ourselves
- Rogers School of Music provided three bands to preform Christmas music inside the Great Hall; a youth band, a teen band, and an adult band. These bands were a great addition and we are already working with the school for next year's tree lighting
- Event Center AV system did not reach out to the new tree location. Use movie in the park speakers and microphone next year

Expenses	
Santa and Elf	\$896.00
Horse Trolley	\$1,800.00
Supplies and decor	\$78.47
Total Expenses	\$2,774.47



Skate with Santa

- Sunday, December 7, 2025 at the TruStone Center from 4:00-5:10pm
- 133 paid admission tickets, one free hot chocolate per paid admission
- 96 hot chocolate tickets redeemed

Expenses	
Santa	\$350.00
Hot chocolate supplies	\$114.62
Total Expenses	\$464.62





Facility Rentals

November

Facility	Rentals	Revenue
LCP Sunroom		
Private Rentals	6	\$861.25
City of Rogers	1	
LCP Pavilion		
Private Rentals	0	\$0.00
City of Rogers	0	
LCP Combo		
Private Rentals	0	\$0.00
City of Rogers	0	
NCP Pavilion		
Private Rentals	0	\$0.00
City of Rogers	0	
Total		\$861.25

December

Facility	Rentals	Revenue
LCP Sunroom		
Private Rentals	2	\$276.25
City of Rogers	0	
LCP Pavilion		
Private Rentals	0	\$0.00

City of Rogers	0	
LCP Combo		
Private Rentals	0	\$0.00
City of Rogers	0	
NCP Pavilion		
Private Rentals	0	\$0.00
City of Rogers	0	
Total		\$276.25

Event Center

Events in October:

- 17 Non-profit (reduced fee)
- 16 City (no fee)
- 12 Paid (full fee)

October Booking Statistics:

- 3 contracts processed for 2025 events
- 4 contracts processed for 2026 events
- 8 new inquiries about future rentals
- 7 facility tours

Event Center Notes:

Fire alarm/telephone system needed resetting.

New Countertop piece for bar area was installed.

Sound system is acting up again but is being looked at with J. Becher.

21st Century Bank Event Center Use & Revenue Statistics for October 2025: Account Type	Hours Used	Total Revenue
Individual	115.25	\$ 16,672.50

Internal	28	\$ 0
Non-Profit	69	\$ 3,025.00
Total	212.25	\$ 19,697.50

Events in November:

- 13 Non-profit (reduced or no fee)
- 15 City (no fee)
- 6 Paid (full fee)

November Booking Statistics:

- 1 contract processed for 2025 events
- 5 contracts processed for 2026 events
- 8 new inquiries about future rentals
- 2 facility tours

Event Center Notes:

Event Center hosted a handful of senior activities while the Community Room was under renovation.

Started using Cintas for rug, mop, and towel service.

Several event cancellations which reduced the overall expected revenue for the month.

21st Century Bank Event Center Use & Revenue Statistics for November 2025:

Account Type	Hours Used	Total Revenue
Individual	32	\$ 5,402.50
Internal	34	\$ 0
Non-Profit	89	\$ 5,057.50
Total	155	\$ 10,460.00

21st Century Bank Event Center Projected Use & Revenue for November 2025:

Account Type	Hours	Total Revenue
Individual	33.50	\$ 7,040.00
Internal	62.00	\$ 0
Non-Profit	95.08	\$ 6,095.00
Total	206.75	\$ 13,135.00

21st Century Bank Event Center Booked Use & Revenue for 2026 (as of 11/30/2025):

Account Type	Hours	Total Revenue
Individual	265.73	\$ 31,437.50
Internal	417	\$ 1,450.00
Non-Profit	336.75	\$ 16,433.75
Total	1019.48	\$ 49,321.25

Senior Center Updates:

Below is a chart showing the number of meals served so far in 2025 and are divided out to show the Total Meals Served, Take Out Meals, and Dine In meals. The price of meals increased from \$5 to \$7 starting in January 2025.

2023 average monthly meals are based only on the months of March-December due to available data.

We no longer have Heritage Place ordering take-out meals while they are figuring out their management change.

No dining on October 28-30 due to a Conference, but we added a special dining day on Halloween.

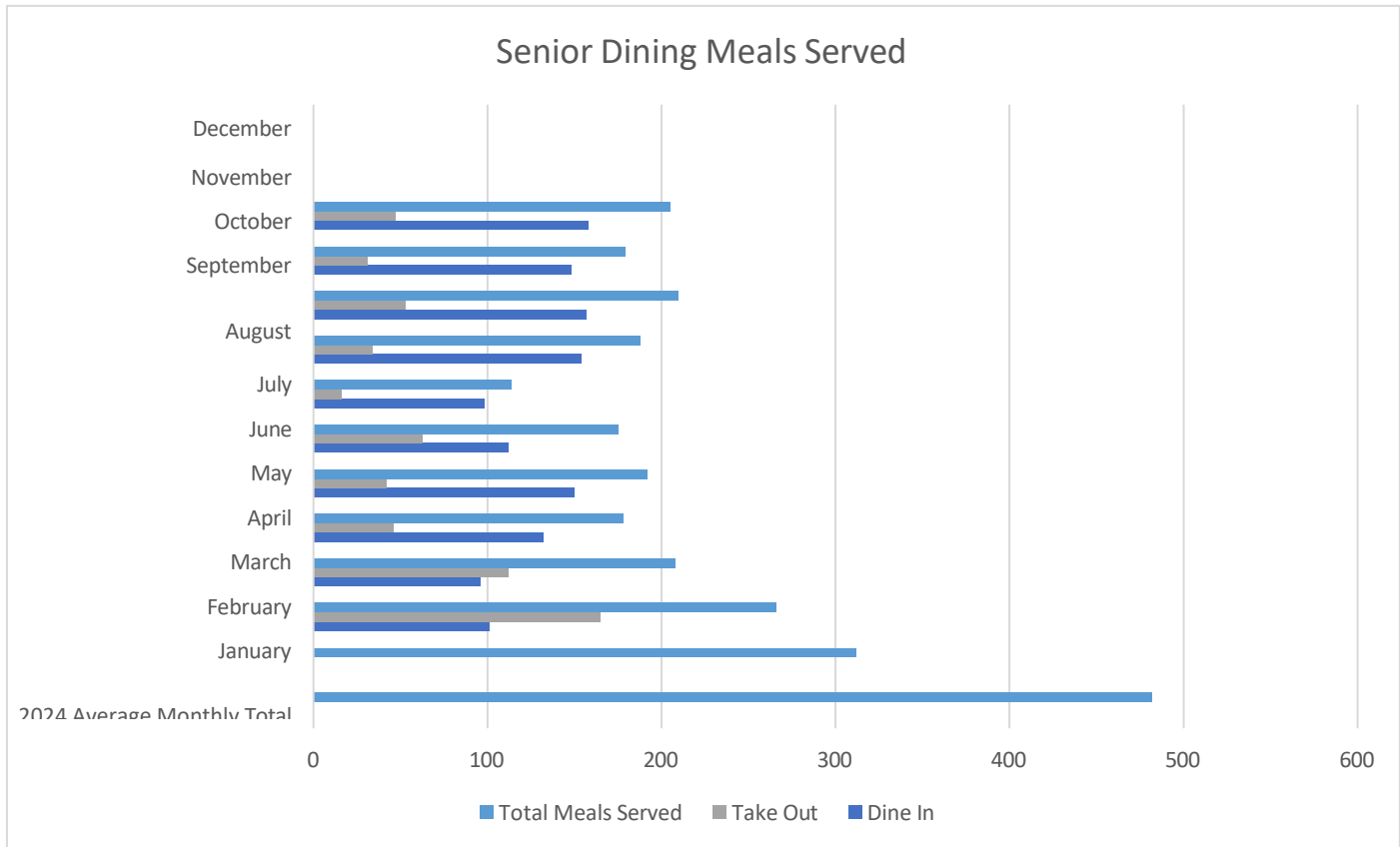

Program Updates Report

Smart Cookie Series: How to Buy & Sell your Home at the Same Time



Date: Thursday, October 23

Attendance: 6 participants

Presenter: Kristi Nemec

Summary: This informative session, part of the Smart Cookie Series, provided participants with practical guidance on navigating the complex process of buying and selling a home simultaneously. Real estate expert Kristi Nemec shared valuable tips on market timing, financing options, and contingency planning. Attendees engaged in a lively Q&A, gaining clarity on how to manage the transition smoothly and avoid common pitfalls.

Midday Mixer: Halloween Hullabaloo

Date: Friday, October 31

Time: 11:30 AM–1:30 PM

Location: Community Room/Senior Center

Attendance: 26 meals served

Summary: The Senior Center hosted a festive Halloween celebration filled with food, fun, and a touch of magic. Guests enjoyed a hearty catered meal from Hy-Vee featuring Swiss steak, green beans, mashed potatoes, and gravy. The highlight of the afternoon was a captivating performance by magician Tom Anderson, who entertained the crowd with spellbinding tricks and illusions. The event brought plenty of smiles and seasonal spirit to all who attended.



Birthday Bingo Bash



Date: October 21

Time: Bingo at 10:30 AM; Lunch at 12:00 PM

Attendance: 20 Bingo participants; 49 meals served

Summary: Birthday Bingo Bash kicked off with great success, bringing together community members for a lively morning of Bingo followed by a delicious pot roast lunch. This monthly event celebrates participants with birthdays during the month, who receive a complimentary meal. The program fosters a warm, inclusive atmosphere where seniors can connect, celebrate, and enjoy a bit of fun and festivity.

Fall Craft & Bake Sale

Date: October 25

Time: 9:00 AM - 2:00 PM

Attendance: ~200

Summary: The Rogers Seniors Group hosted a vibrant and well-attended Fall Craft & Bake Sale, featuring 36 local vendors offering handmade goods and seasonal items. The bake sale was a major hit, selling out by 11:00 AM, and guests enjoyed a hearty sloppy joe lunch available for purchase. The event created a festive atmosphere and provided a great opportunity for community connection and support of local crafters.



Below is a chart showing the number of meals served so far in 2025 and are divided out to show the Total Meals Served, Take Out Meals, and Dine In meals.

Dining was limited in November due to the renovations. We had 3 normal meal days and one special dining day only.

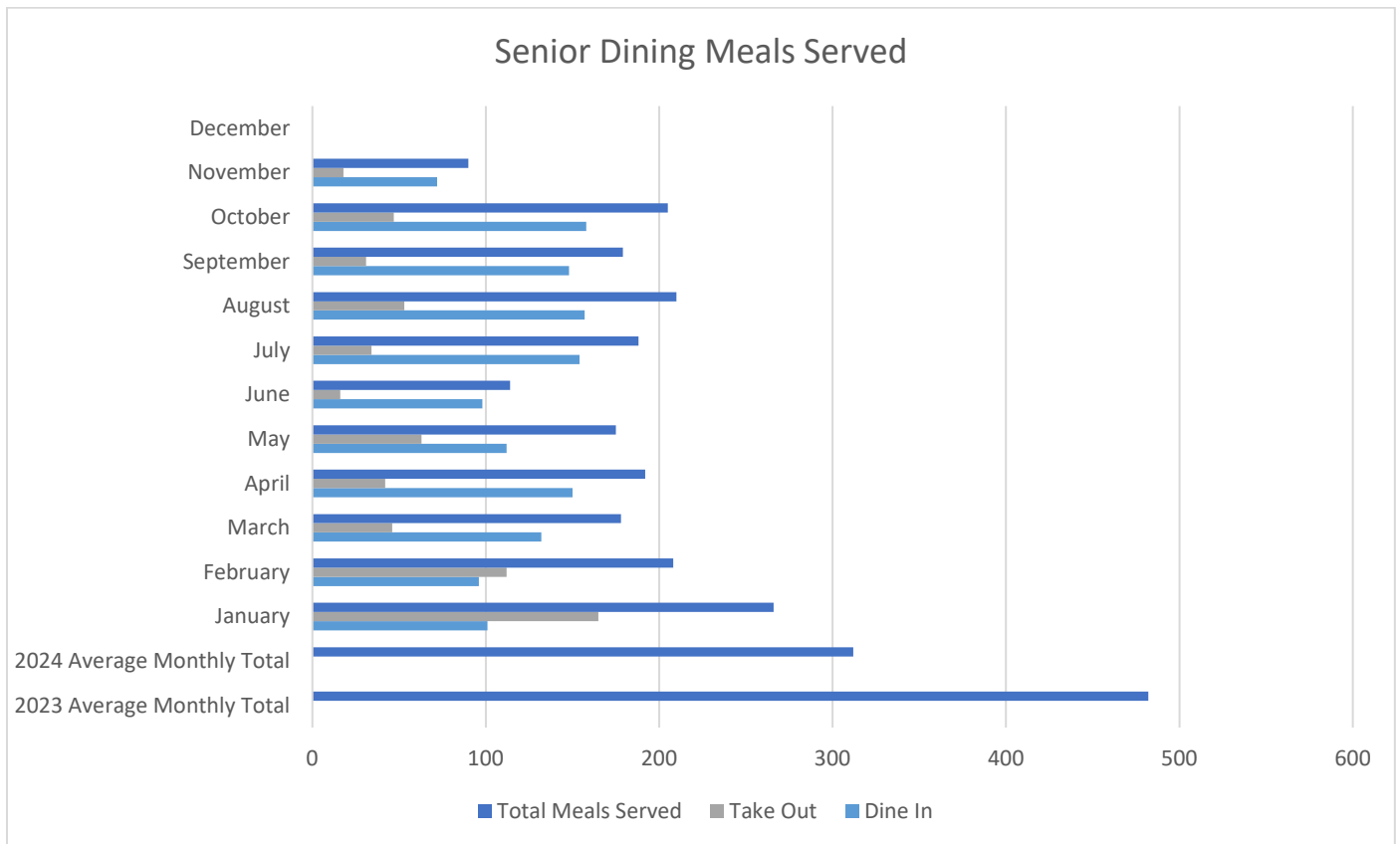

Program Updates Report

Road Trip: “Laverne & Lucy” at the Sheldon Theatre

Date: Tuesday, November 18

Attendance: 33 participants from both Rogers & Otsego Senior Centers

Summary:

Participants from the Rogers and Otsego Senior Centers enjoyed a delightful day trip to Red Wing for a memorable afternoon of food, fun, and entertainment. The outing began with a 12:00 PM luncheon at the historic St. James Hotel, featuring a hearty menu of Swedish meatballs with buttermilk-dill gravy, Yukon Gold mashed potatoes, green beans, dinner rolls, and a self-serve beverage station offering coffee, tea, and water.

Following lunch, the group made their way to the historic Sheldon Theatre—America’s first city-owned theater, originally opened in 1904 and beautifully restored in 1986.

At 2:00 PM, attendees were treated to a high-energy matinee performance by Laverne & Lucy, a dynamic duo known for their side-splitting comedy, musical talent, and interactive stage presence. Their show blended rock and roll, bluegrass, novelty songs, and improvisational humor, creating a lively and laughter-filled experience for all. With decades of professional stage experience, their performance was a highlight of the month and left the audience smiling all the way home.



Midday Mixer: Friendsgiving Feast

Date: Tuesday, November 25

Time: 11:30 AM–1:30 PM

Location: 21st Century Bank Event Center

Attendance: 39 meals served

Summary:

This month’s Midday Mixer featured a festive Friendsgiving Feast, bringing together community members for a warm and welcoming holiday celebration. Guests enjoyed a traditional

Thanksgiving meal of roasted sliced turkey, mashed potatoes with gravy, glazed carrots, dinner rolls, jellied cranberries, and a sweet finish of pumpkin and pecan pie topped with whipped cream. Live music by Vinnie Rose added to the cheerful atmosphere.

With the Senior Center temporarily closed for renovations, we opened the Event Center lobby early at 9:00 AM to host our Community Café, offering hot coffee and fresh donuts. The day continued with a variety of card games—including Texas Canasta, 500, and Pinochle—providing opportunities for socializing and fun until the building closed at 5:00 PM.



Birthday Bingo Bash

Date: November 6

Time: Bingo at 10:30 AM; Lunch at 12:00 PM

Attendance: 15 Bingo participants; 26 meals served

Summary:

The Birthday Bingo Bash continues to be a cherished monthly tradition, bringing together community members for a lively morning of Bingo followed by a delicious pot roast lunch. This ongoing program celebrates participants with birthdays during the month, who receive a complimentary meal. With each event, the program strengthens community bonds and fosters a warm, inclusive atmosphere where seniors can connect, celebrate, and enjoy a bit of fun and festivity.